

## Description

- 1.6x0.81x0.65mm physical size
- Solder-free design
- Designed to UL248-1
- RoHS compliant, Halogen free and Lead-free

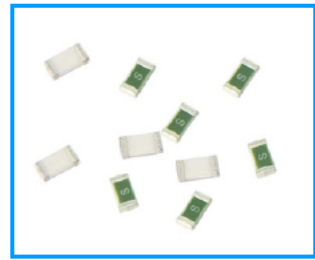

- 
- 
- 
- 

## Dimensions

(Unit: mm)

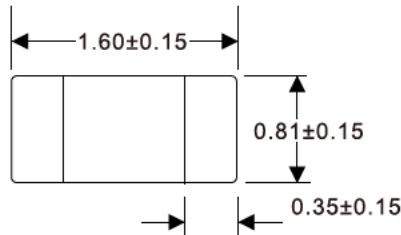

## Agency information

File Number: E340427, Guide JDYX2/JDYX8

## Specifications

Part No.	Rated Voltage (Vdc)	Rated Current (A)	Breaking Capacity (A)	Typical Cold Resistance (mOhms)	Typical Voltage Drop (mV)	Typical Pre-Arcing I <sup>2</sup> t (A <sup>2</sup> Sec)	Alpha Mark
R06.000.0.25	63	0.25	50A	3100	1435	0.0012	D
R06.000.0.375		0.375		1600	1250	0.0028	E
R06.000.0.5		0.5		1000	750	0.005	F
R06.000.0.75		0.75		440	550	0.015	G
R06.000.1		1		257	390	0.02	B
R06.000.1.5		1.5		137	320	0.07	H
R06.000.2		2		70.5	220	0.14	K
R06.000.2.5		2.5		52	200	0.25	L
R06.000.3		3		34	155	0.30	O
R06.000.3.5		32		3.5	23	135	0.50
R06.000.4	4		20.5	130	0.80	S	
R06.000.5	5		13.25	115	1.6	T	
R06.000.6	6		8.9	100	2.6	V	
R06.000.7	7		6.95	95	3.3	X	
R06.000.8	8		5.43	90	4.5	Z	

\* DC Interrupting Rating (Measured at rated voltage, time constant of less than 50 microseconds, battery source)

\* DC Cold Resistance are measured at <10% of rated current in ambient temperature of 25 degrees

\* Typical Pre-arcing I<sup>2</sup>t are measured at 10In Current

\* For fuse below 1A, the color of glass coating is Blue; for 1A and above, it's Green.

## Electrical Characteristics

Rated Current	1.0In	2.0In	2.5In	3.5In
250mA~750mA	4.0 hour min	60 sec max	5.0 sec max	.
1~5A	4.0 hour min	60 sec max	5.0 sec max	.
6~7A	4.0 hour min		5.0 sec max	.
8A	4.0 hour min	-	5.0 sec max	.

## Installation Recommendations

### 1 Wave Soldering Parameters

Reflow Condition		Pb-free assembly
Pre Heat	- Temperature Min ( $T_{smin}$ )	150°C
	- Temperature Max ( $T_{smax}$ )	200°C
	- Time (Min to Max) ( $t_s$ )	60 - 120 seconds
Average Ramp-up Rate (Liquidus Temp ( $T_L$ ) to peak)		3°C/second max,
TS(max) to $T_L$ - Ramp-up Rate		5°C/second max,
Reflow	- Temperature ( $T_L$ ) (Liquidus)	217°C
	- Temperature ( $t_L$ )	60 - 150 seconds
Peak Temperature ( $T_p$ )		260±0/-5°C
Time within 5°C of actual peak Temperature ( $t_p$ )		30 seconds
Ramp-down Rate		6°C/second max
Time 25°C to peak Temperature ( $T_p$ )		8 minutes max.
Do not exceed		260°C

Solder Pot Temperature: 260°C max  
Solder Dwell Time: 10 Seconds max

### 2 Hand-Solder Parameters

Solder Iron Temperature: 280±5°C  
Heating Time: 5 Seconds min  
Generally, hand-soldering is not recommended

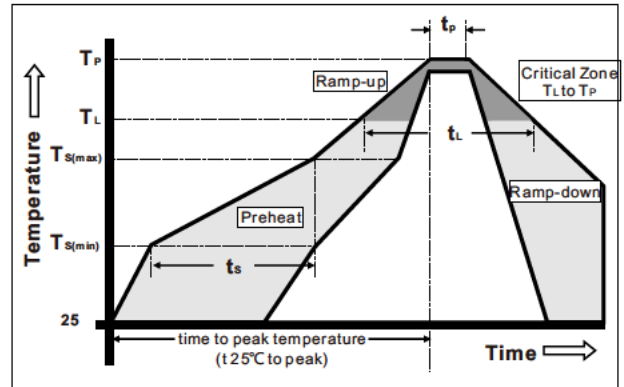

## Part Numbering System

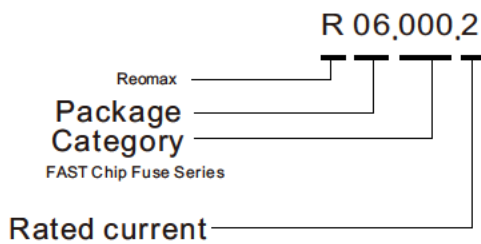

## Product Characteristics

Materials	<b>Body:</b> Ceramic <b>Terminations:</b> Silver over-plated with tin <b>Element:</b> Alloy (Ag, Cu, Zn) <b>Cover Coat:</b> Glass
Operating Temperature	-55°C to 125°C Consult temperature derating curve chart
Thermal Shock	300 cycles -55°C to 125°C
Humidity	MIL-STD-202F, Method 103B, Condition D
Vibration	Per MIL-STD-202F, Method 201A
Insulation Resistance (After Opening)	Greater than 10,000 ohms
Resistance to Soldering Heat	MIL-STD-202G, Method 210F, Condition D

## Time Current Curve

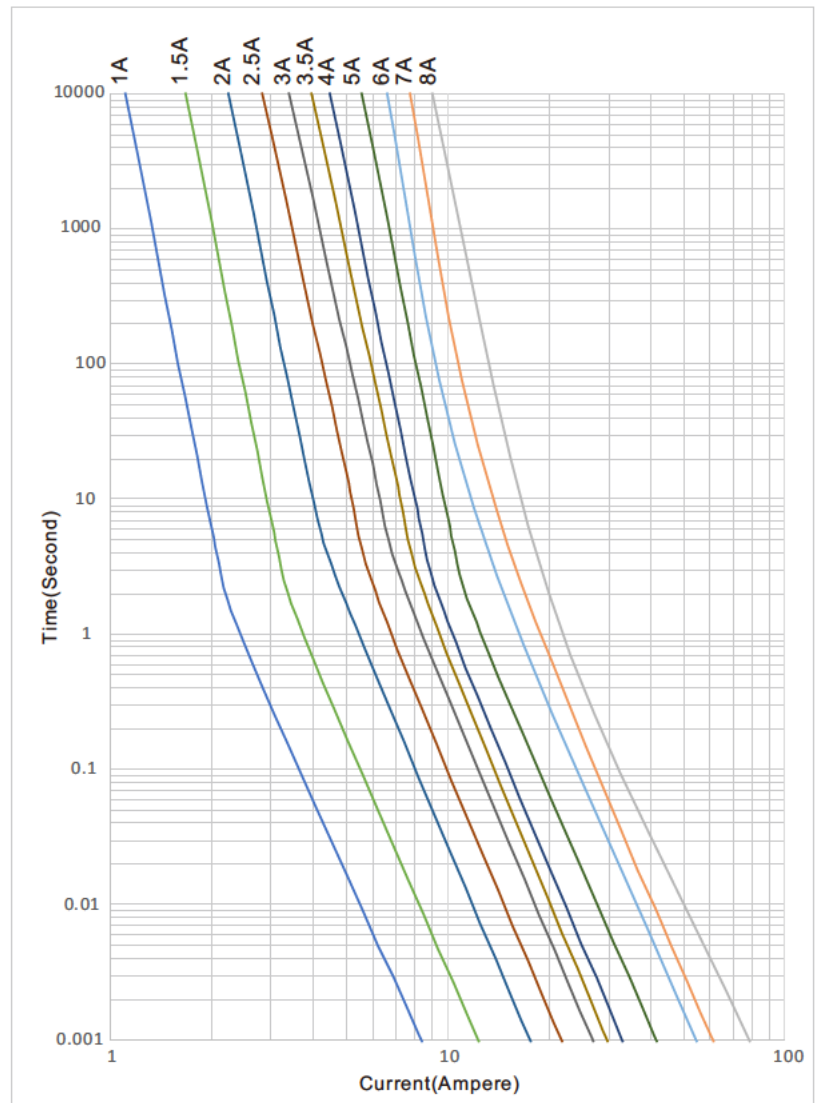
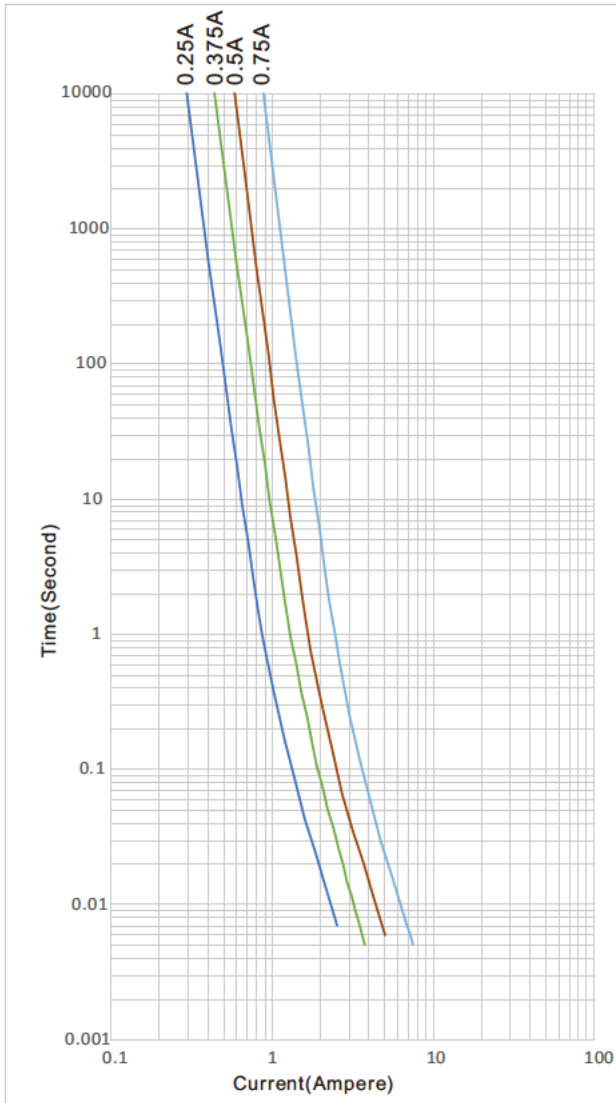

## Packaging

5,000 pieces of fuses in plastic or paper taper

5000pcs)

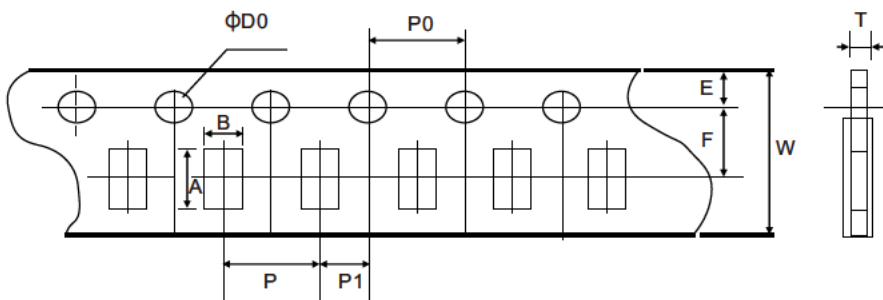

Type	A	B	W	F	E
Spec	1.85±0.10	1.10±0.10	8.00±0.10	3.50±0.05	1.75±0.10
Type	P	P0	P1	D0	T
Spec	4.00±0.10	4.00±0.10	2.00±0.05	1.50±0.10	0.65±0.10

(Unit: mm)