

RECOMMENDED  
建議剝線尺寸

MATERIAL : BODY-BRASS  
CONTACT-PHOSPHOR BRONZE  
INSULATOR-TEFLON  
CONTACT-BRASS  
LOCK WASHER-BRASS  
NUT-BRASS  
SLEEVE-BRASS  
O-RING-SI RUBBER  
FINISH : BODY-NICKEL PLATING  
SLEEVE-NICKEL PLATING  
LOCK WASHER-NICKEL PLATING  
NUT-NICKEL PLATING  
CONTACT-GOLD PLATING OVER NICKEL

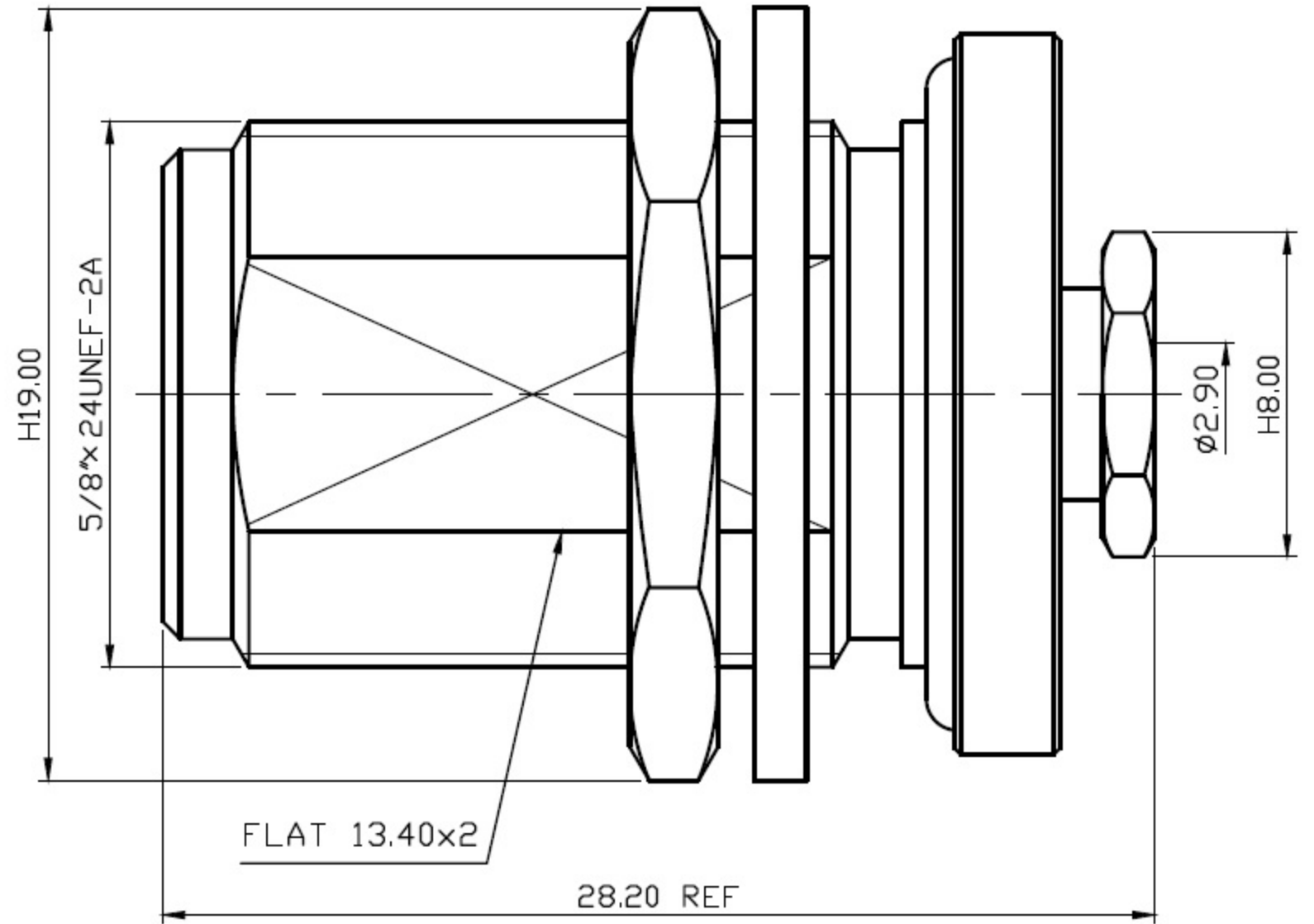

DIMENSIONS ARE IN MILLIMETERS  
TOLERANCE

· × ±0.5  
· × × ±0.1  
· × × × ±0.05

ANGLE ±3°

SCALE 4:1

REV A-1

DRAWN

DATE 99. 12. 30

APPROVAL

DATE

**SCHMID-M**

TITLE N Straight Bulkhead Jack Clamp for RG174u,  
RG188A/u, RG316u

DRAWING NO N-2218-TGN

FILE NO