



SLD10 SERIES 10W, AC-DC CONVERTER

SLD10 series ----is a compact size power converter offered by Schmid-M. It features universal input voltage, taking both DC and AC input voltage, low power consumption, high efficiency, high reliability, safer isolation. It offers good EMC performance, meets IEC/EN61000-4, CISPR22/EN55022 , UL60950 and EN60601 standards, and widely used in industrial, medical, electricity, instruments, telecommunication and civil applications. For harsh EMC environment, this series of products must use the refered application circuit.



PRODUCT FEATURES

1. Universal input :85 ~ 264VAC/120~370VDC
2. AC and DC dual-use(input from the same terminal)
3. High efficiency, high power density
4. Output over voltage, short circuit and over temperature protection
5. Low ripple and noise
6. Low loss, green power
7. Meet UL60950 and EN60601 standards
8. Industrial, medical level specifications
9. Mounting: PCB mounting, Chassis mounting with Screw
Terminals, DIN-Rail mounting

PART NUMBER SYSTEM

SLD10-20B24A2S

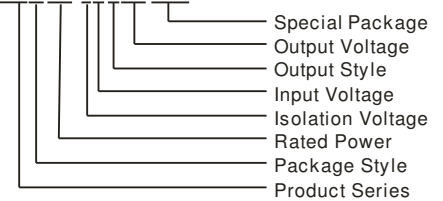

SELECTION GUIDE

Approval	Model	Package	Power	Output (Vo1/Io1)	Ripple and Noise (typ)	Efficiency (%) (typ)	Standby Power (typ)
UL/CE	SLD10-20B03	53.8X28.8X19.0mm	6.6W	3.3V/2000mA	50mV	70	0.4W
	SLD10-20B05			5V/2000mA		74	0.4W
	SLD10-20B09		9V/1100mA	76		0.45W	
	SLD10-20B12		12V/900mA	76		0.4W	
	SLD10-20B15		15V/700mA	78		0.5W	
	SLD10-20B24		24V/450mA	80		0.6W	

INPUT SPECIFICATIONS

Input Voltage Range	85~264VAC, 120~370VDC
Input Frequency	47~440Hz
Input Current	110VAC 230mA, typ 230VAC 150mA, typ
Inrush Current	110VAC 10A, typ 230VAC 20A, typ
Leakage Current	0.1mA (typ)@ Vin=230Vac
Recommended External Input Fuse (Special package series include fuse)	2A/250V Slow-Blow

OUTPUT SPECIFICATIONS

Voltage set accuracy	±2% (3.3V: ±3%)	
Input variation	±0.5% (typ)	
Load variation (10% to 100%)	±1% (typ)	
Ripple& noise(p-p)	20MHz Bandwidth 50mV(typ) 100mV (max)	
Short circuit protection	Continuous, and auto resume	
Over current protection	≥110% Io	
Maximum capacitive load (µF)	SLD10-20B03	8000
	SLD10-20B05	8000
	SLD10-20B09	560
	SLD10-20B12	1200

	SLD10-20B15	1000
	SLD10-20B24	200

COMMON SPECIFICATIONS

Temperature ranges	Operating		-25°C~+70°C	
	Power derating	(+55°C~+70°C)	2% / °C	
		(-25°C~0°C)	2% / °C	
	Storage		-40°C~+105°C	
Case temperature		+95°Cmax		
Hold-up time	(Vin=230VAC)		50ms(typ)	
Humidity			95%(max)	
Temperature coefficient			0.02%/°C	
Switching frequency			60kHz(typ)	
Isolation			4000VAC/1Min	
EMC	EMI	CE	CISPR22/EN55022 CLASS A(without external circuit) / CLASS B(with typical applications Figure 3)	
		RE	CISPR22/EN55022 CLASS A(without external circuit) / CLASS B(with typical applications Figure 3)	
	EMS	ESD	IEC/EN 61000-4-2 Contact ±6KV /Air ±8KV	perf. Criteria B
		RS	IEC/EN 61000-4-3 10V/m	perf. Criteria A
		EFT	IEC/EN 61000-4-4 ±2 KV (without external circuit)	perf. Criteria B
			IEC/EN 61000-4-4 ±4 KV (with typical applications Figure 3)	perf. Criteria B
		Surge	IEC/EN 61000-4-5 ±1KV (without external circuit)	perf. Criteria B
			IEC/EN 61000-4-5 ±2KV/±4KV (with typical applications Figure 3)	perf. Criteria B
		CS	IEC/EN61000-4-6 10 Vr.m.s	perf. Criteria A
		PFM	IEC/EN61000-4-8 10A/m	perf. Criteria A
Voltage dips, short and interruptions immunity		IEC/EN61000-4-11 0%-70%	perf. Criteria B	
Safety standards		IEC60601,EN60601,UL60950		
Safety approvals		EN60601,UL60950		
Safety Class		CLASS II		
Case material		UL94V-0		
Install		PCB mounting, Chassis mounting with Screw Terminals, DIN-Rail mounting		
MTBF		>300,000H @25°C		
Package	PCB mounting		53.8X28.8X19.0mm	
	A2Chassis mounting with Screw Terminals		96.1X54.0X27.5mm	
	A4DIN-Rail mounting		96.1X54.0X32.1mm	
	A2SChassis mounting with Screw Terminals		76.0X31.5X27.8mm	
	A4SDIN-Rail mounting		76.0X31.5X32.4mm	
Weight	50g(PCB mounting) 100g(A2Chassis mounting with Screw Terminals) 140g(A4DIN-Rail mounting) 70g(A2SChassis mounting with Screw Terminals) 90g(A4SDIN-Rail mounting)			

Note: 1.Ripple and Noise were measured by the method of anear measure (more details refer to the anear measure).
2.Unless otherwise specified, all specifications above are measured at rated input voltage and rated output load, TA=25°C, humidity < 75%.

ANEAR MEASURE

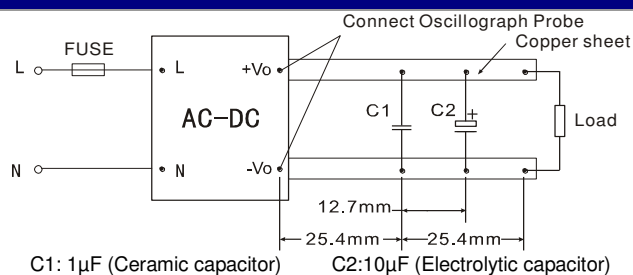

TEMPERATURE VS LOAD

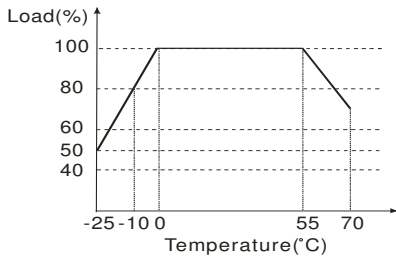

INPUT VOLTAGE VS LOAD

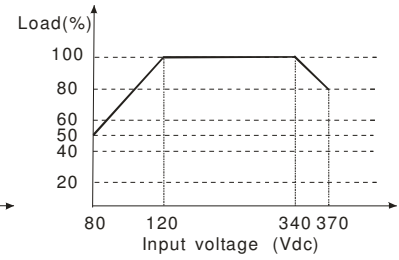
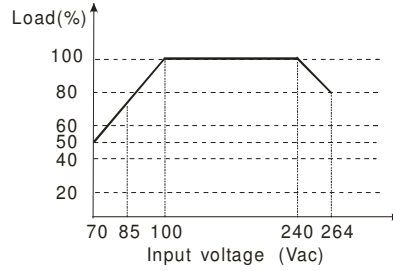

TYPICAL APPLICATIONS

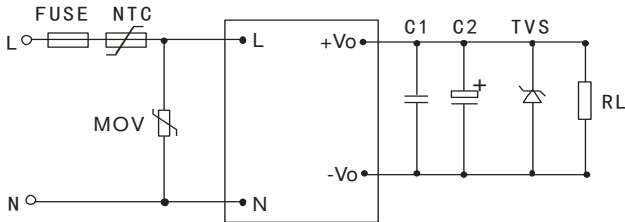

Figure 1: SLD10 application circuit

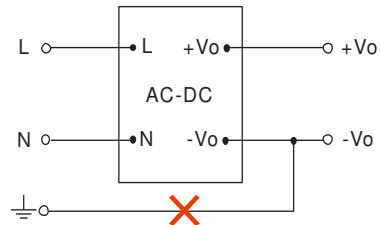

Figure 2: Note: This application is not supported for this series.

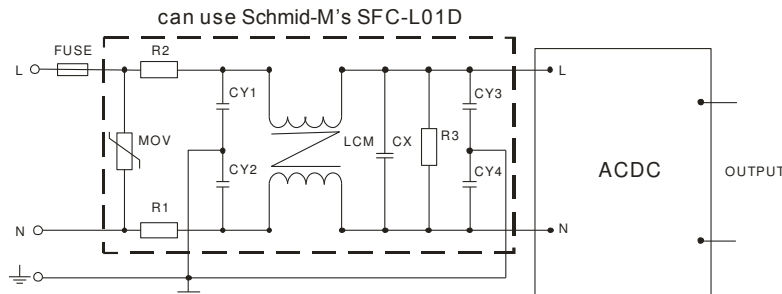

Figure 3: SLD10 series Recommended circuit for application require higher EMC standard (external circuit output same as above)

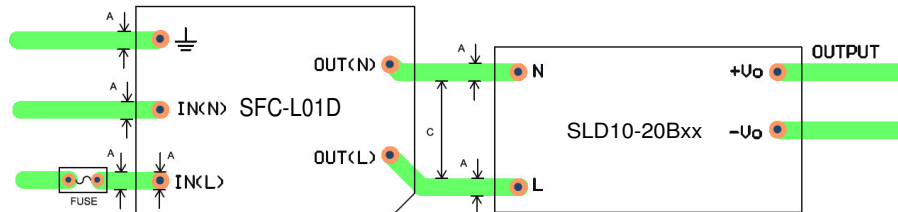

Figure 4: EMC application circuit PCB layout
Safety and recommend wiring: linewidth $A \geq 3\text{mm}$, $C \geq 9\text{mm}$

EXTERNAL CAPACITORS TYPICAL VALUE

Model	C1	C2	TVS
SLD10-20B03	1 μF /50V	220 μF /10V	SMBJ7.0A
SLD10-20B05	1 μF /50V	220 μF /10V	SMBJ7.0A
SLD10-20B09	1 μF /50V	120 μF /25V	SMBJ12A
SLD10-20B12	1 μF /50V	120 μF /25V	SMBJ20A
SLD10-20B15	1 μF /50V	120 μF /25V	SMBJ20A
SLD10-20B24	1 μF /50V	68 μF /35V	SMBJ30A

Note:

- Output filtering capacitors C1 is ceramic capacitor, it is used to filter high frequency noise. C2 is electrolytic capacitors. It is recommended to use high frequency and low impedance electrolytic capacitors. For capacitance and current of capacitor please refer to manufacture's datasheet. Voltage derating of capacitor should be 80% or above. TVS is a recommended component to protect post-circuits (if converter fails). External input NTC model is recommended to use 5D-9.
- For standard EMC requirement, please refer to figure 1, if higher EMC requirement, please refer to figure 3 or figure 4.
MOV: Varistor, model: 561KD14, it is used to protect the device under surge;
R1, R2: 2 Ω /3W Winding resistor;
R3: 1M Ω /2W;
CY1, CY2, CY3, CY4: 1000 pF/400VAC;
CX: 0.22 μF /275VAC;
LCM: 10mH-30mH, can use Schmid-M's SFL2D-z5-103;
SFC-L01D: Schmid-M's 2KV/4KV Surge protector.
- FUSE: It must be connected to FUSE, SLD10 is recommended to use 2A/250V.

PCB MOUNTING WITH SOLDER PINS

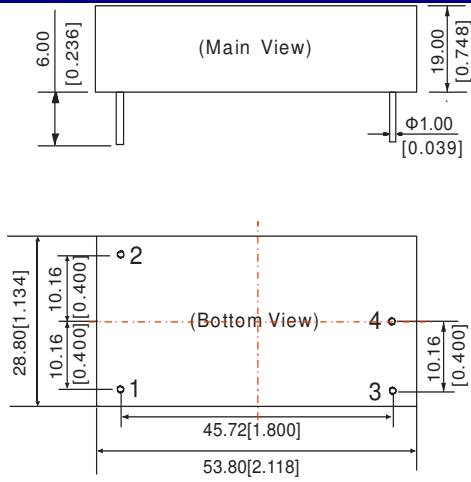

Note:
Unit: mm[inch]
Pin diameter tolerances: $\pm 0.10\text{mm} [\pm 0.004\text{inch}]$
General tolerances: $\pm 0.50\text{mm} [\pm 0.020\text{inch}]$

RECOMMENDED FOOTPRINT

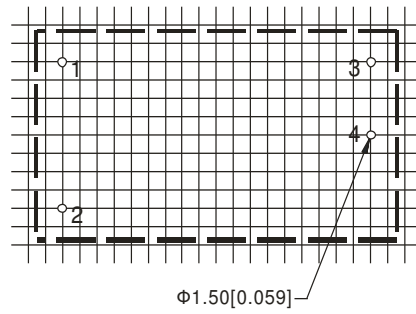

Note: grid 2.54*2.54mm.

FOOTPRINT DETAILS	
PIN	FUNCTION
1	N
2	L
3	+Vo
4	-Vo

SLD10XXA2 CHASSIS MOUNTING WITH SCREW TERMINALS

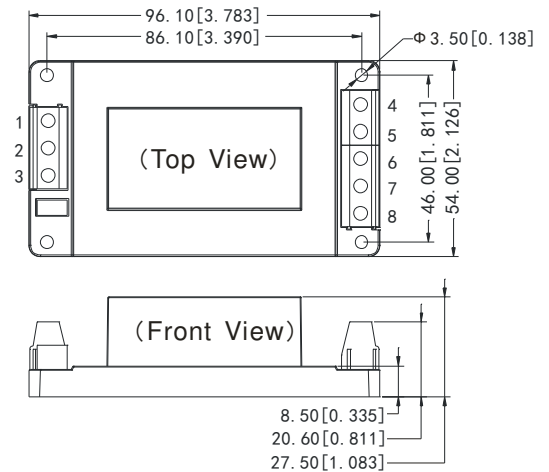

Footprint Details								
Pin	1	2	3	4	5	6	7	8
Function	NC	AC(N)	AC(L)	+Vo	NC	-Vo	NC	NC

Note:
Unit: mm[inch]
General tolerances: $\pm 0.50\text{mm} [\pm 0.020\text{inch}]$

SLD10XXA4 DIN-RAIL MOUNTING

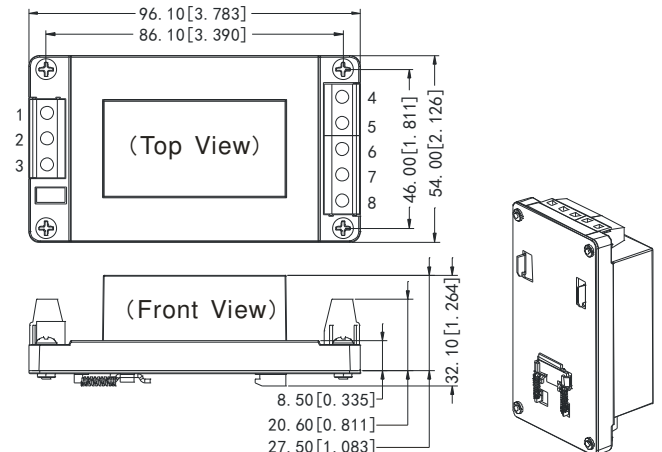

Footprint Details								
Pin	1	2	3	4	5	6	7	8
Function	NC	AC(N)	AC(L)	+Vo	NC	-Vo	NC	NC

Note:
Unit: mm[inch]
General tolerances: $\pm 0.50\text{mm} [\pm 0.020\text{inch}]$

SLD10XA2S CHASSIS MOUNTING WITH SCREW TERMINALS



Footprint Details				
Pin	1	2	3	4
Function	AC(N)	AC(L)	+Vo	-Vo

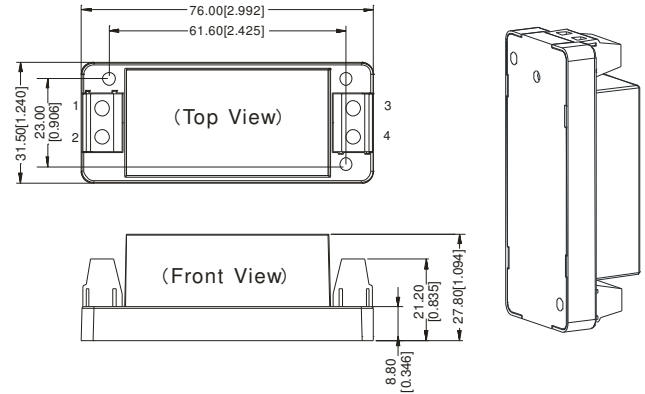

Note:
Unit: mm[inch]
General tolerances: $\pm 0.50\text{mm}[\pm 0.020\text{inch}]$

SLD10XA4S DIN-RAIL MOUNTING



Footprint Details				
Pin	1	2	3	4
Function	AC(N)	AC(L)	+Vo	-Vo

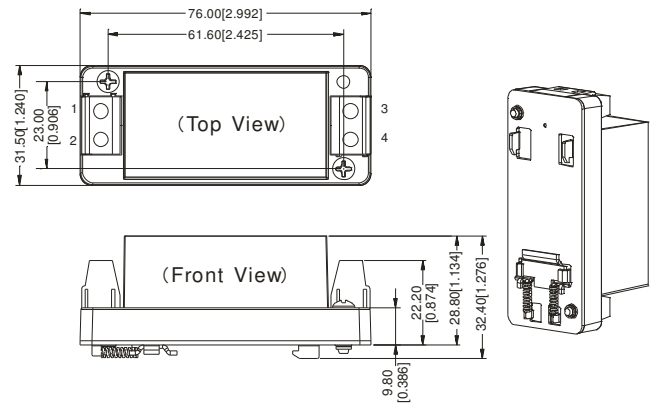

Note:
Unit: mm[inch]
General tolerances: $\pm 0.50\text{mm}[\pm 0.020\text{inch}]$

PACKAGE DIAGRAM

PCB mounting Series

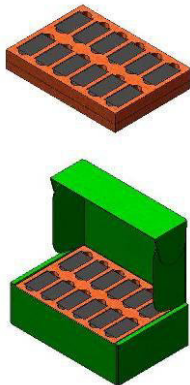

Inner packaging box dimensions:
L*W*H=255*170*80mm
Packaging quantity: 24pcs
Outer packaging box dimensions:
L*W*H=405*380*305mm
Packaging quantity: 144pcs

Special Package Series(A2/A4)

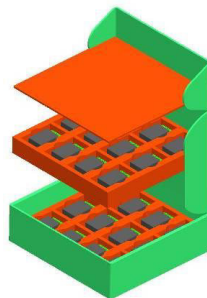

Inner packaging box dimensions:
L*W*H=365*350*105mm
Packaging quantity: 24pcs
Outer packaging box dimensions:
L*W*H=390*360*245mm
Packaging quantity: 48pcs

Special Package Series(A2S/A4S)



Inner packaging box dimensions:
L*W*H=365*350*105mm
Packaging quantity: 48pcs
Outer packaging box dimensions:
L*W*H=390*360*245mm
Packaging quantity: 96pcs