

Thermistors

Series MF1

Features

- **Characteristic curve** according to DIN 44081
- **Resistance** $R_{25} < 100 \text{ Ohm}$
- **Mounting in windings** of electrical motors and transformers for the monitoring of limit temperatures
- **Miniature construction**/external diameter $\Rightarrow > 3\text{mm}$ depending on insulation
- **Protection paint coat** against chemical influences
- **Extended range of temperature** up to 190°C
- **100%-controlled production**/ the resistance R_{25} and the nominal response temperature of each component is proved.
- **The thermistors construction** corresponds, concerning strength and insulation, to the requirements for mounting in copper windings.
- **Customer designed solutions** can be realized cost-saving.
- **Quick and confidently response action**



Description

PTC Thermistors are temperature-sensitive ceramic semi-conductor resistors with a positive temperature coefficient.

The PTC-sensors change their resistance, when reaching the nominal temperature precipitously.

Within changes of temperature of only 10K arise changes of resistance larger than 1kOhm.

PTCs will be mounted on a releasing tool, which changes gear over a relais after reaching the nominal response temperature.

Technical data

	Single	Triplet
Max. working voltage U_{max}	30V	
Nominal temperature ϑ_{NAT}	60°C to 190°C	
Tolerance about ϑ_{NAT}	± 5K	
Reproducibility about ϑ_{NAT}	± 5K	
Resistance at 25°C ¹	≤ 100 Ω	≤ 300 Ω
Resistance at $\vartheta_{NAT} - T^1$	≤ 550 Ω	≤ 1650 Ω
Resistance at $\vartheta_{NAT} + T^1$	≥ 1330Ω	≥ 3990 Ω
Resistance at $\vartheta_{NAT} + 15 K^2$	≥ 4 kΩ	≥ 12 kΩ
Thermal reaction time	< 5 s	
insulation strength	2,5 kV	
Max. working temperature	200 °C	
ambient temperature	- 25°C to 200°C	

¹⁾ Tension continue ≤ 1,5 V

²⁾ Tension continue ≤ 7,5 V

Resistance - temperature - characteristic curve

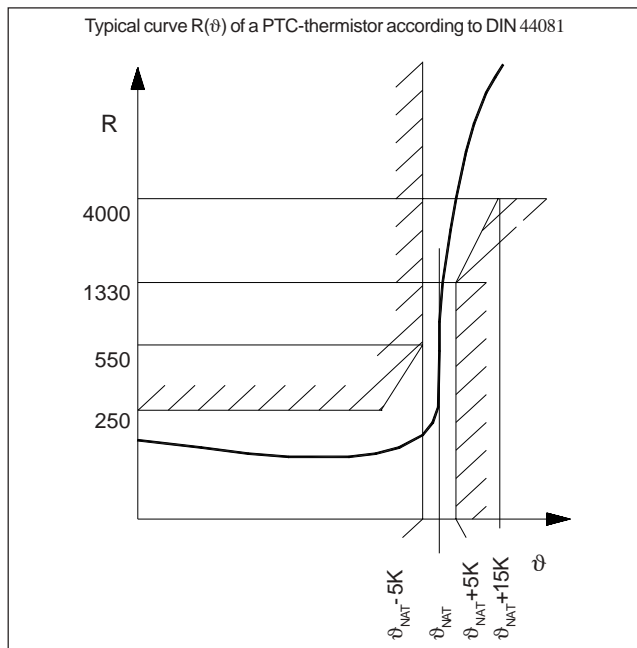

The characteristic curve points are no-load resistance values. Self-heating has to be avoided. If necessary, pulsating voltage has to be worked with. At temperatures below -20°C the PTC thermistor is able to accept resistance values exceeding 250 Ω.

Installation advices

Basically PTC thermistors have to be installed parallelly to the winding wires. Air inclusion influences thermal direct coupling negatively and should therefore be avoided.

The PTC thermistor's mechanical wear during the forming of the end windings can be reduced by correct installation..

All rights reserved.

Because TMC has no access to the details of the application, respectively, TMC is not able to take any liability for perhaps improper use of the PTC or for the violation of the claims of others, patent violation for example..

Dimensions (in mm)

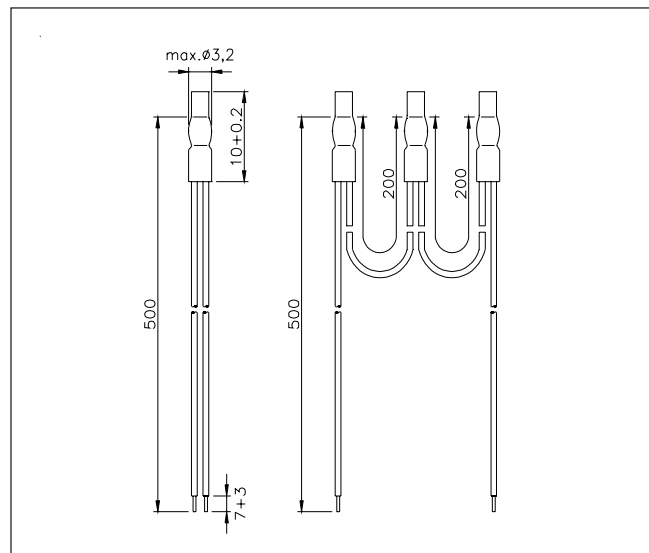

Standard lead: Teflon stranded wire, AWG 26 = 0,14 mm², colour according to the nominal temperature. Connecting lead in yellow

Marking and order codes

TN	colour	Single	Triplet
60	white/grey	MF1-E060	MF1-D060
70	white/brown	MF1-E070	MF1-D070
80	white/white	MF1-E080	MF1-D080
90	green/green	MF1-E090	MF1-D090
100	red/red	MF1-E100	MF1-D100
110	brown/brown	MF1-E110	MF1-D110
120	grey/grey	MF1-E120	MF1-D120
130	blue/blue	MF1-E130	MF1-D130
140	white/blue	MF1-E140	MF1-D140
145	white/black	MF1-E145	MF1-D145
150	black/black	MF1-E150	MF1-D150
155	blue/black	MF1-E155	MF1-D155
160	blue/red	MF1-E160	MF1-D160
170	white/green	MF1-E170	MF1-D170
180	white/red	MF1-E180	MF1-D180
190	black/grey	MF1-E190	MF1-D190

Order example for special types

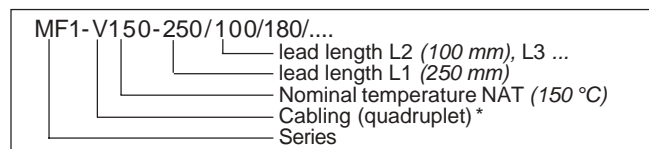

* Cabling: E: single, Z: double, D: triple, V: quadruplet, S: sextuplets, N: ninefold

We reserve the right to modify specification and dimensions. Regarding the information of this brochure there can't lay claim of liability or to acceptance guarantee.

This new data sheet obsoletes all previous issues.
Stand 06/10