

K120

Peso Kg/m **8.10**
Weight Kg/m

Rt °C/W **0.82**

Lung. campione mm **100**
Sample length mm

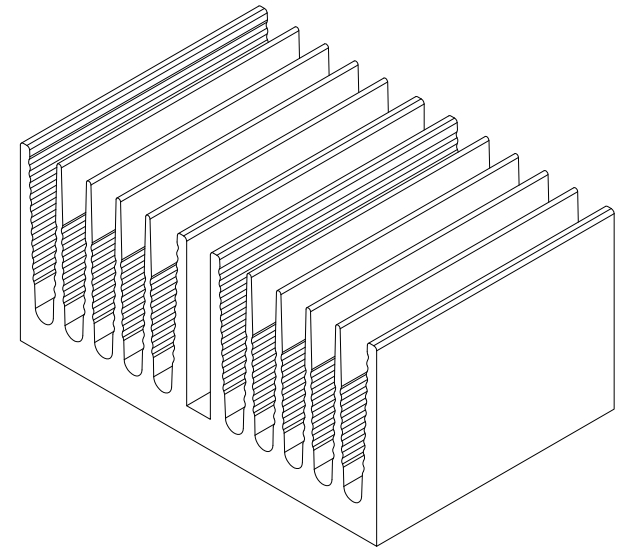
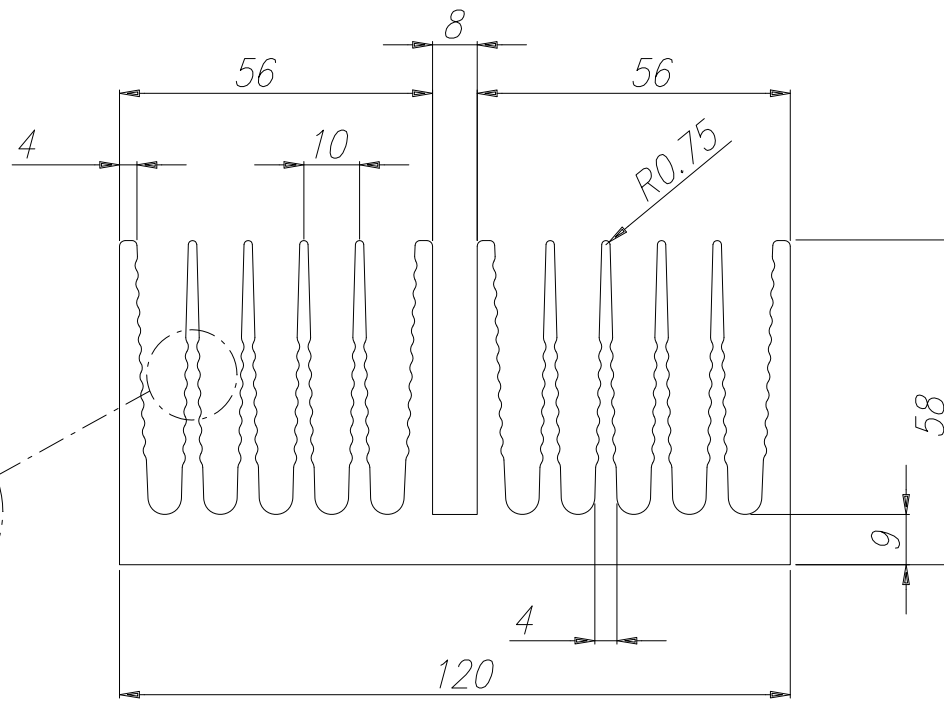
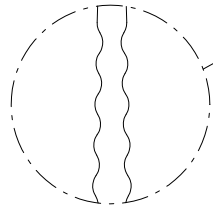

ATECNOAL
BOLOGNA - ITALY

ATECNOAL
MECHANICAL ENGINEERING FOR ELECTRONICS

Notes:

ATD Elektronik s.r.o.
Lužnice 10
344 01 Domažlice
Tel.: 379 723 915
Fax: 379 725 868
www.atd-elektronik.cz
info@atd-elektronik.cz

COMPANY
WITH QUALITY MANAGEMENT
SYSTEM CERTIFIED BY DNV
= ISO 9001 : 2000 =

