

**K100A**

Peso Kg/m **4.20**  
Weight Kg/m

Rt °C/W **1.15**

Lung. campione mm **100**  
Sample length mm

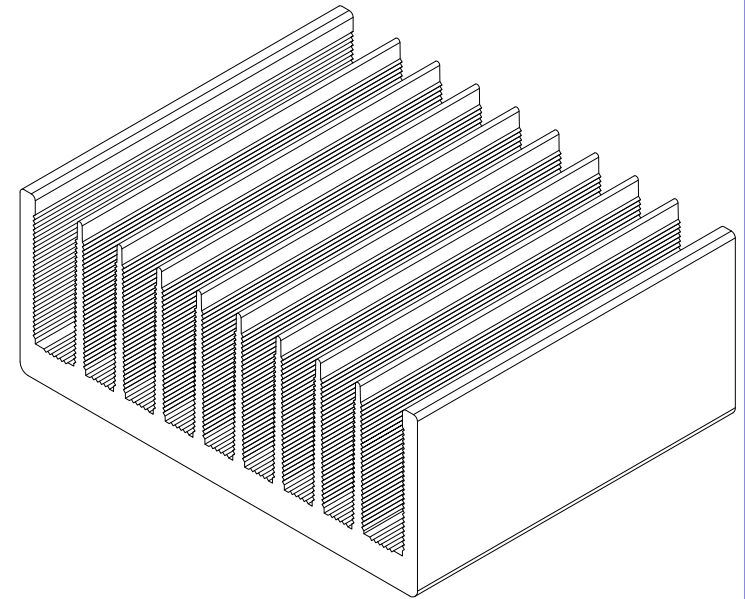
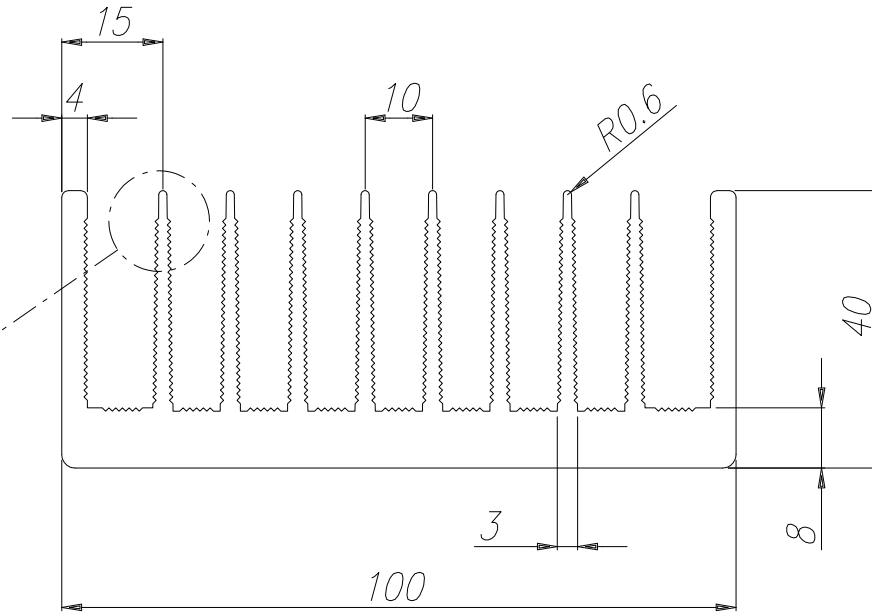
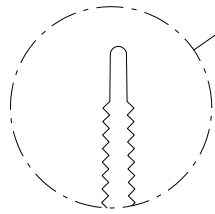

**A**TECNOAL  
BOLOGNA - ITALY

**A**TECNOAL  
MECHANICAL ENGINEERING FOR ELECTRONICS

ATD Elektronik s.r.o.  
Lužnice 10  
344 01 Domažlice  
Tel.: 379 723 915  
Fax: 379 725 868  
www.atd-elektronik.cz  
info@atd-elektronik.cz

COMPANY  
WITH QUALITY MANAGEMENT  
SYSTEM CERTIFIED BY DNV  
= ISO 9001 =

Notes:

-----  
-----  
-----  
-----  
-----  
-----  
-----  
-----  
-----  
-----  
-----  
-----

