

I 105M

Peso Kg/m 1.38
Weight Kg/m 1.38

Dimension H on request
Dimension L on request

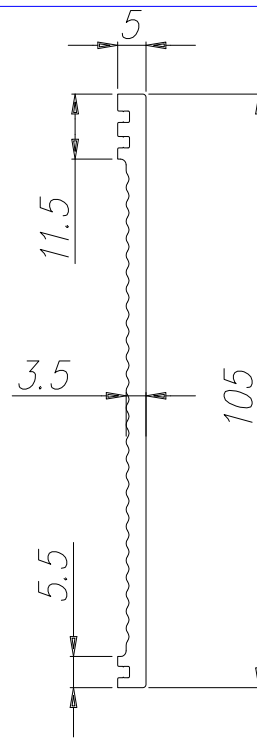
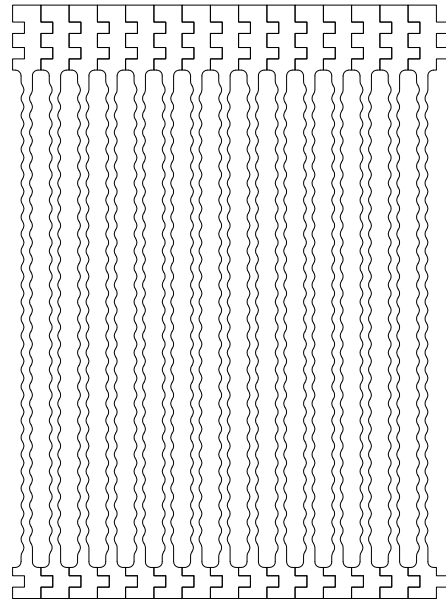
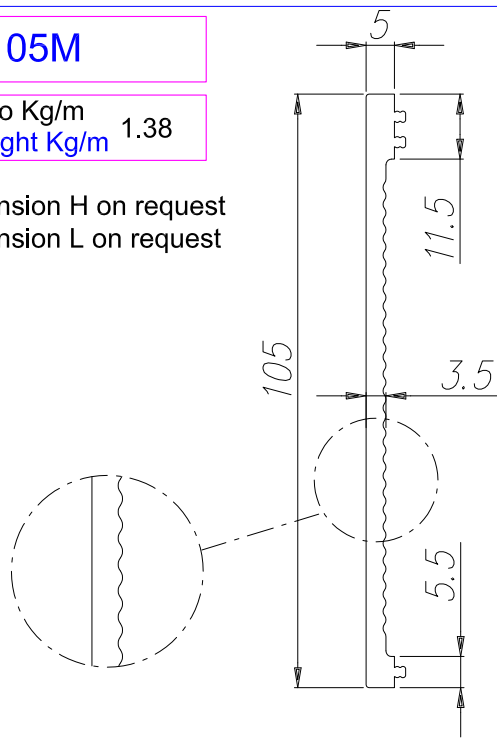

I 105F

Peso Kg/m 1.00
Weight Kg/m 1.00

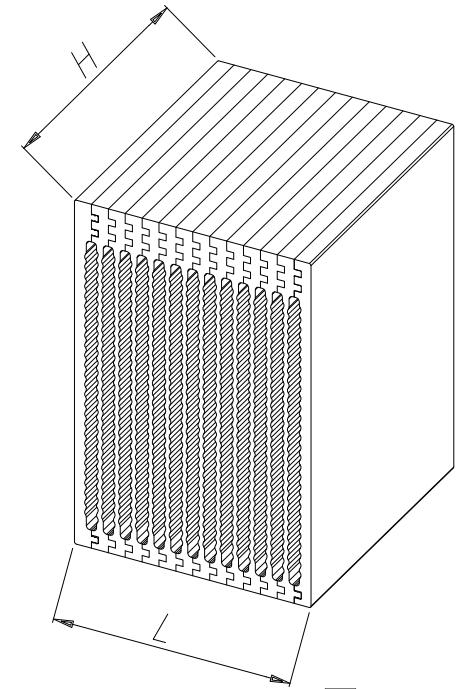

ATECNOAL
BOLOGNA - ITALY

ATECNOAL
MECHANICAL ENGINEERING FOR ELECTRONICS

ATD Elektronik s.r.o.
Luženice 10
344 01 Domažlice
Tel.: 379 723 915
Fax: 379 725 868
www.atd-elektronik.cz
info@atd-elektronik.cz

COMPANY
WITH QUALITY MANAGEMENT
SYSTEM CERTIFIED BY DNV

≡ ISO 9001 ≡

Notes:

ATD
ELEKTRONIK s.r.o.