







MINI SERIES

CHOGORI

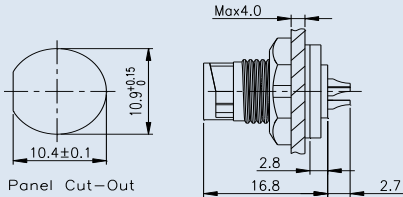
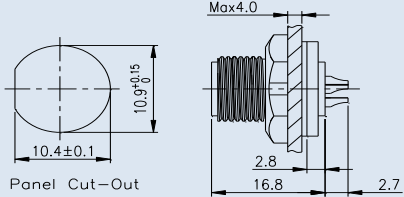
MINI Series Specifications

Mini Series , Front Panel Mount & Male pin

Description	Front Panel Mount Lock Bayonet Type, Solder	Front Panel Mount Screw Type, Solder
Figure		
Drawing		

Part-No.	Lock Bayonet Type		Screw Type	
	Contacts	Part-Number	Contacts	Part-Number
	2	21002525-01 	2	21002515-01 
	3	21003525-01 	3	21003515-01 
	4(5A)	21004525-01	4(5A)	21004515-01
	4(2A)	21004525-02	4(2A)	21004515-02
	5	21005525-01	5	21005515-01
	6	21006525-01	6	21006515-01
	2+4	21204525-01	2+4	21204515-01
	7	21007525-01	7	21007515-01
	8	21008525-01	8	21008515-01

Specifications									
Number of Contacts	2	3	4	4	5	6	2+4	7	8
Wire Gauge	0.519mm ² (20AWG)				0.34mm ² (22AWG)				
Panel Thickness	Max. 4.0mm								
Environmental Protection	IP67/IP68								
Mechanical Life	500 mating cycles								
Operating Temperature	- 45°C - 105°C								
Voltage Rating	110V	110V	110V	110V	50V	50V	50V	50V	50V
Rated Current(40°C)	5A	5A	5A	2A	2A	2A	5+2A	2A	2A