

AZS

AZC

Capacitors PCB type

- AZC 2 pins
- AZS 4 pins
- Capacitance Tolerance: -20 + 20% - standard (M)
- Climatic category: 25/105/56
- Case: 30x40 - 45x100
- Temperature - 25°C + 105°C

Mechanical Outlines

- Case: aluminium made
- Terminals: solder pin
- Sealing: hermetic on Rubber Bakelite cover
- Pressure Release Vent: onto aluminium case
- No insulated bottom
- Sleeve: self-extinguishing thermo shrinkable
- Size: see enclosed drawings
- External Material UL94-V0

Ordering Code: Example

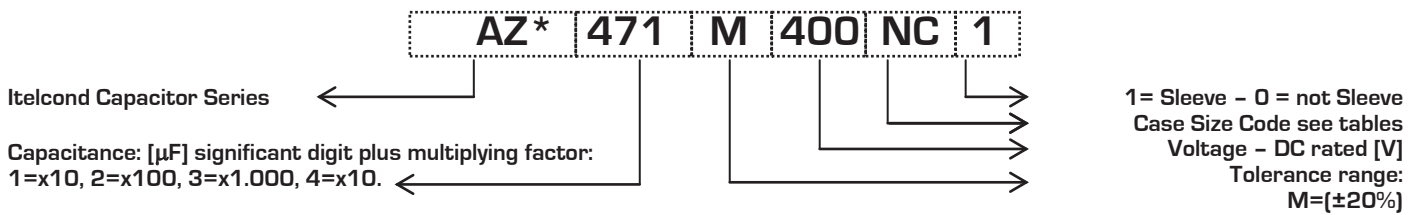

Ripple Current

The allowable values of ripple current in Ampères, are related to the temperature and frequency by following equation:

$$I_{\text{Ripple}} = K_t \cdot K_f \cdot I_{\text{Ripple}@105^\circ\text{C}}$$

Where:

- $I_{\text{Ripple}@105^\circ\text{C}}$ is the limit given by tables, @ 105°C/100HZ
- K_t is the Temperature Correlation Factor
- K_f is the Frequency Correlation Factor

Note .Superimposed alternating voltage summed to DC volage must not exceed rated voltage, rated ripple current must not be exceeded and no reverse polarity is allowed

°C	50	65	75	85	95	105
Kt	2.40	2.20	2.10	1.80	1.30	1.00

Table 1-Kt Values

Kf	
Vn/Hz	V>160
50	0.88
100	1.00
300	1.20
400	1.25
500	1.35
>1000	1.40

Table 2-Kf Values

Expected Lifetime End of Life Criteria

During useful life typical electrical parameters of electrolytic capacitor are subject to change.

End of Life criteria, when rated temperature, voltage and ripple are applied, are:

$$\frac{\Delta C}{C_{t0}} \leq 30\% \quad \text{Equation 1}$$

$$ESR \leq 3 \cdot ESR_{t0} \quad \text{Equation 2}$$

$$I_f \leq I_{ft0} \quad \text{Equation 3}$$

where t_0 is the initial value

Voltage Endurance Test Requirements

On Voltage Endurance Test are based Expected Lifetime Curves.

End of Life criteria, when rated temperature, and voltage are applied for 2'000hrs, are

$$\frac{\Delta C}{C_{t0}} \leq 10\% \quad \text{Equation 4}$$

$$ESR \leq 1,3 \cdot ESR_{t0} \quad \text{Equation 5}$$

$$I_f \leq I_{ft0} \quad \text{Equation 6}$$

where t_0 is the initial value

Expected Lifetime Vs Temperature and Ripple Current

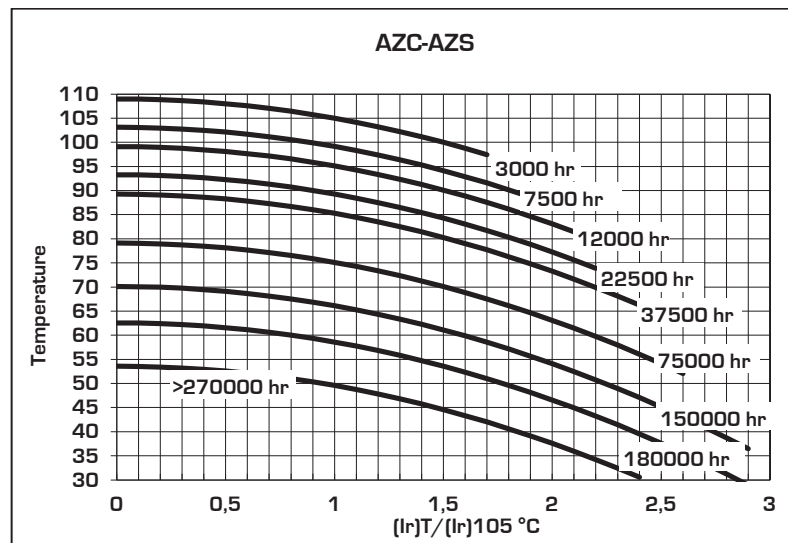

Table 3

Leakage Current

After the rated voltage has been applied to the capacitor for 5 minutes the leakage current must be within those limits.

Maximum limit	@25°C	$I_f \leq 0,004 \times C \times V$
Operating limit	@25°C	$I_f \leq 0,001 \times C \times V$

Where: I_f =leakage current [μ A], C =capacitance [μ F], V =rated voltage [V]

Surge Voltage

Working Voltage	200	250	400	450
Surge Voltage	230	290	440	495

	Capacitance	Case	Diam	Height	Tanδ	ESRmax typ		Zmax	Iripple @100Hz		Ordering Code
	[μF]@100Hz		[mm]	[mm]	[%]@100Hz	[mΩ]@100Hz	[mΩ]@10KHz	[mΩ]@10KHz	[A]@85°C	[A]@105°C	* = C, 2 Pins S, 4 Pins
200	470	MB	30	40	0,10	271	217	203	2,9	1,6	AZ*471M200MB1
	680	MB	30	40	0,10	187	150	141	3,5	1,9	AZ*681M200MB1
	1000	MC	30	50	0,10	127	102	96	4,7	2,6	AZ*102M200MC1
		NB	35	40	0,10	127	102	96	4,6	2,6	AZ*102M200NB1
	1500	NC	35	50	0,10	85	68	64	6,2	3,5	AZ*152M200NC1
	2200	NE	35	75	0,10	58	46	43	9,0	5,0	AZ*222M200NE1
		QC	45	50	0,10	58	46	43	8,7	4,8	AZ*222M200QC1
	3300	PG	40	100	0,10	39	31	29	13,5	7,5	AZ*332M200PG1
		QE	45	75	0,10	39	31	29	12,7	7,0	AZ*332M200QE1
3900	QG	45	100	0,10	33	26	24	15,7	8,7	AZ*392M200QG1	
250	470	MB	30	40	0,10	271	217	203	2,9	1,6	AZ*471M250MB1
	680	MC	30	50	0,10	187	150	141	3,8	2,1	AZ*681M250MC1
		NB	35	40	0,10	187	150	141	3,8	2,1	AZ*681M250NB1
	1000	NB	35	40	0,10	127	102	96	4,6	2,6	AZ*102M250NB1
		NC	35	50	0,10	127	102	96	5,1	2,8	AZ*102M250NC1
	1500	NE	35	75	0,10	85	68	64	7,4	4,1	AZ*152M250NE1
		PC	40	50	0,10	85	68	64	6,7	3,7	AZ*152M250PC1
		PE	40	75	0,10	85	68	64	8,0	4,4	AZ*152M250PE1
	2200	PG	40	100	0,10	58	46	43	11,0	6,1	AZ*222M250PG1
400	220	MB	30	40	0,10	579	463	434	2,0	1,1	AZ*221M400MB1
	330	MB	30	40	0,10	386	309	290	2,4	1,4	AZ*331M400MB1
	470	MC	30	50	0,10	271	217	203	3,2	1,8	AZ*471M400MC1
		NB	35	40	0,10	271	217	203	3,2	1,8	AZ*471M400NB1
		NC	35	50	0,10	271	217	203	3,5	1,9	AZ*471M400NC1
	560	NC	35	50	0,10	227	182	171	3,8	2,1	AZ*561M400NC1
	680	NC	35	50	0,10	187	150	141	4,2	2,3	AZ*681M400NC1
		NN	35	60	0,10	187	150	141	4,5	2,5	AZ*681M400NN1
		NE	35	75	0,10	187	150	141	5,0	2,8	AZ*681M400NE1
		PC	40	50	0,10	187	150	141	4,5	2,5	AZ*681M400PC1
	820	NN	35	60	0,10	155	124	117	5,0	2,8	AZ*821M400NN1
		PN	40	60	0,10	155	124	117	5,4	3,0	AZ*821M400PN1
	1000	NN	35	60	0,10	127	102	96	5,5	3,1	AZ*102M400NN1
		NE	35	75	0,10	127	102	96	6,1	3,4	AZ*102M400NE1
		PN	40	60	0,10	127	102	96	5,9	3,3	AZ*102M400PN1
		PE	40	75	0,10	127	102	96	6,5	3,6	AZ*102M400PE1
		QC	45	50	0,10	127	102	96	5,9	3,3	AZ*102M400QC1
		QN	45	60	0,10	127	102	96	6,3	3,5	AZ*102M400QN1
	1200	PE	40	75	0,10	106	85	80	7,2	4,0	AZ*122M400PE1
		PG	40	100	0,10	106	85	80	8,1	4,5	AZ*122M400PG1
1500	PG	40	100	0,10	85	68	64	9,1	5,1	AZ*152M400PG1	
	QN	45	60	0,10	85	68	64	7,8	4,3	AZ*152M400QN1	
	QE	45	75	0,10	85	68	64	8,6	4,8	AZ*152M400QE1	

	Capacitance	Case	Diam	Height	Tan δ	ESRmax typ		Zmax	Iripple @100Hz		Ordering Code
	[μ F]@100Hz		[mm]	[mm]	[%]@100Hz	[m Ω]@100Hz	[m Ω]@10KHz	[A]@85°C	[A]@105°C	* = C, 2 Pins S, 4 Pins	
400	1800	QG	45	100	0,10	71	57	53	10,6	5,9	AZ*182M400QG1
	2200	QG	45	100	0,10	58	46	43	11,8	6,5	AZ*222M400QG1
450	220	MB	30	40	0,10	579	463	434	2,0	1,1	AZ*221M450MB1
	330	MC	30	50	0,10	386	309	290	2,7	1,5	AZ*331M450MC1
		NB	35	40	0,10	386	309	290	2,7	1,5	AZ*331M450NB1
	470	NC	35	50	0,10	271	217	203	3,5	1,9	AZ*471M450NC1
	560	NE	35	75	0,10	227	182	171	4,5	2,5	AZ*561M450NE1
		PC	40	50	0,10	227	182	171	4,1	2,3	AZ*561M450PC1
	680	NN	35	60	0,10	187	150	141	4,5	2,5	AZ*681M450NN1
		NE	35	75	0,10	187	150	141	5,0	2,8	AZ*681M450NE1
		PE	40	75	0,10	187	150	141	5,4	3,0	AZ*681M450PE1
		QC	45	50	0,10	187	150	141	4,9	2,7	AZ*681M450QC1
	820	NE	35	75	0,10	155	124	117	5,5	3,1	AZ*821M450NE1
	1000	PE	40	75	0,10	127	102	96	6,5	3,6	AZ*102M450PE1
		PG	40	100	0,10	127	102	96	7,4	4,1	AZ*102M450PG1
		QE	45	75	0,10	127	102	96	7,0	3,9	AZ*102M450QE1
1200	PG	40	100	0,10	106	85	80	8,1	4,5	AZ*122M450PG1	
1500	QG	45	100	0,10	85	68	64	9,7	5,4	AZ*152M450QG1	

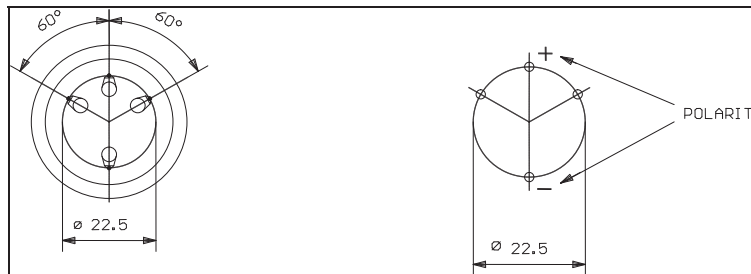
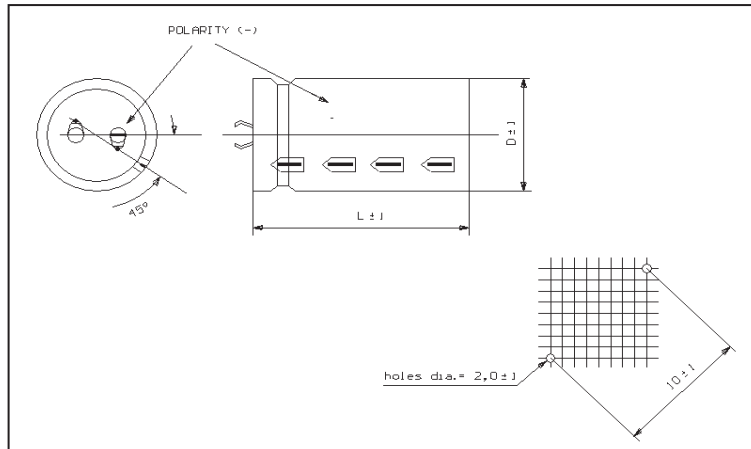
Dimension, Quantity and Weight for box

Case		Connections			Packaging	
Code	DxL	PIN		Pcs/Box	Weight/box	
		Number	Lenght			
MB	30x105	2		6.3	100	4-6
MC	30x50	2		6.3	100	4-6
NB	35x40	2	4	6.3	100	6-8
NC	35x50	2	4	6.3	100	6-8
NN	35x60	2	4	6.3	100	5-7
NE	35x75	2	4	6.3	50	6-8
PB	40x40	2	4	6.3	100	6-8
PC	40x50	2	4	6.3	100	8-9
PN	40x60	2	4	6.3	100	8-10
PE	40x75	2	4	6.3	50	9-11
PG	40x100	2	4	6.3	50	6-8
QC	45x50		4	6.3	30	6-8
QN	45x60		4	6.3	30	
QE	45x75		4	6.3	30	7-9
QG	45x100		4	6.3	30	8-10

All dimensions in mm, torque in Nm, weight in kg

*Aluminium Electrolytic Capacitors – Series AZ**