

AZK

Capacitors PCB type - DIN style Solder Pins

- AZK DIN 4/5 pins
- Capacitance Tolerance: -20 + 20% - standard (M)
- Climatic category: 25/105/56
- Case: 30x40 - 40x100
- Temperature - 25°C + 105°C

Mechanical Outlines

- Case: aluminium made
- Terminals: solder pin
- Sealing: hermetic on Rubber Bakelite cover
- Pressure Release Vent: onto aluminium case
- No insulated bottom
- Sleeve: self-extinguishing thermo shrinkable
- Size: see enclosed drawings
- External Material UL94-V0

Ordering Code: Example

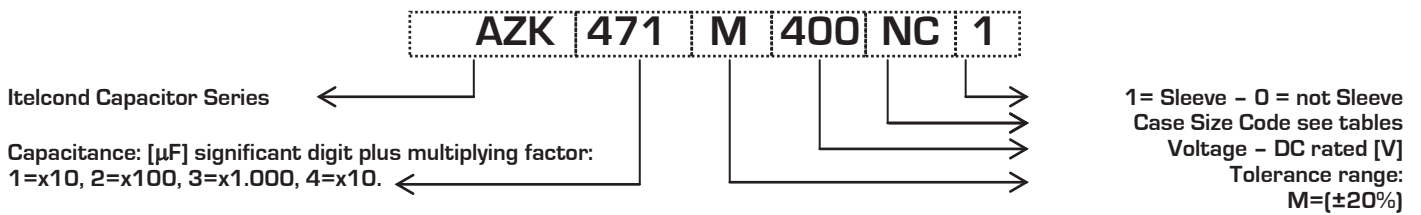

Ripple Current

The allowable values of ripple current in Ampères, are related to the temperature and frequency by following equation:

$$I_{Ripple} = K_t \cdot K_f \cdot I_{Ripple@105^\circ C}$$

Where:

- $I_{Ripple@105^\circ C}$ is the limit given by tables, @ 105°C/100HZ
- K_t is the Temperature Correlation Factor
- K_f is the Frequency Correlation Factor

Note .Superimposed alternating voltage summed to DC volage must not exceed rated voltage, rated ripple current must not be exceeded and no reverse polarity is allowed

°C	50	65	75	85	95	105
K_t	2.40	2.20	2.10	1.80	1.30	1.00

Table 1- K_t Values

	K_f
V_n/Hz	$V>160$
50	0.88
100	1.00
300	1.20
400	1.25
500	1.35
>1000	1.40

Table 2- K_f Values

Expected Lifetime End of Life Criteria

During useful life typical electrical parameters of electrolytic capacitor are subject to change.

End of Life criteria, when rated temperature, voltage and ripple are applied, are:

$$\frac{\Delta C}{C_{t0}} \leq 30\% \quad \text{Equation 1}$$

$$ESR \leq 3 \cdot ESR_{t0} \quad \text{Equation 2}$$

$$I_f \leq I_{ft0} \quad \text{Equation 3}$$

where t_0 is the initial value

Voltage Endurance Test Requirements

On Voltage Endurance Test are based Expected Lifetime Curves.

End of Life criteria, when rated temperature, and voltage are applied for 2'000hrs, are

$$\frac{\Delta C}{C_{t0}} \leq 10\% \quad \text{Equation 4}$$

$$ESR \leq 1,3 \cdot ESR_{t0} \quad \text{Equation 5}$$

$$I_f \leq I_{ft0} \quad \text{Equation 6}$$

where t_0 is the initial value

Expected Lifetime Vs Temperature and Ripple Current

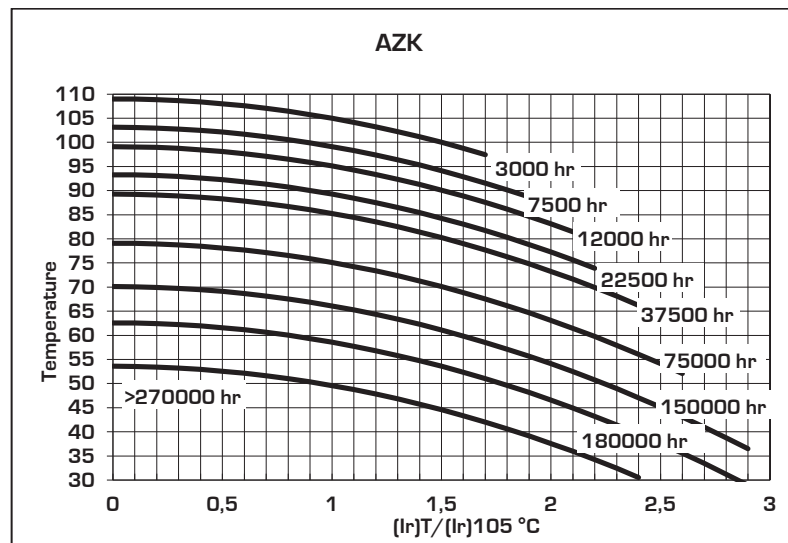

Table 3

Leakage Current

After the rated voltage has been applied to the capacitor for 5 minutes the leakage current must be within those limits.

Maximum limit	@25°C	$I_f \leq 0,004 \times C \times V$
Operating limit	@25°C	$I_f \leq 0,001 \times C \times V$

Where: I_f =leakage current [μA], C =capacitance [μF], V =rated voltage [V]

Surge Voltage

Working Voltage	200	250	400	450
Surge Voltage	230	290	440	495

	Capacitance	Case	Diam	Height	Tanδ	ESRmax typ		Zmax	Iripple @100Hz		Ordering Code
	[μF]@100Hz		[mm]	[mm]	[%]@100Hz	[mΩ]@100Hz	[mΩ]@10KHz	[A]@85°C	[A]@105°C		
200	470	NB	35	40	0,10	271	217	203	3,2	1,8	AZK471M200NB1
	680	NC	35	50	0,10	187	150	141	4,2	2,3	AZK681M200NC1
	1000	NC	35	50	0,10	127	102	96	5,1	2,8	AZK102M200NC1
	1500	NE	35	75	0,10	85	68	64	7,4	4,1	AZK152M200NE1
		PC	40	50	0,10	85	68	64	6,7	3,7	AZK152M200PC1
	2200	PE	40	100	0,10	58	46	43	11,0	6,1	AZK222M200PE1
3300	PG	40	100	0,10	39	31	29	13,5	7,5	AZK332M200PG1	
250	470	MB	30	40	0,10	271	217	203	2,9	1,6	AZK471M250MB1
	680	NB	35	40	0,10	187	150	141	3,8	2,1	AZK681M250NB1
	1000	PC	40	50	0,10	127	102	96	5,5	3,1	AZK102M250PC1
	1500	PE	40	75	0,10	85	68	64	8,0	4,4	AZK152M250PE1
	2200	PG	40	100	0,10	58	46	43	11,0	6,1	AZK222M250PG1
400	330	NB	30	50	0,10	386	309	290	2,7	1,5	AZK331M400NB1
	470	NC	30	50	0,10	271	217	203	3,2	1,8	AZK471M400NC1
	680	NE	40	40	0,10	187	150	141	4,1	2,3	AZK681M400NE1
		PC	35	50	0,10	187	150	141	4,2	2,3	AZK681M400PC1
	1000	NE	35	75	0,10	127	102	96	6,1	3,4	AZK102M400NE1
		PE	35	50	0,10	127	102	96	5,1	2,8	AZK102M400PE1
		PG	40	50	0,10	127	102	96	5,5	3,1	AZK102M400PG1
1500	PG	40	75	0,10	85	68	64	8,0	4,4	AZK152M400PG1	
450	220	NB	30	40	0,10	579	463	434	2,0	1,1	AZK221M450NB1
	330	NC	35	50	0,10	386	309	290	2,9	1,6	AZK331M450NC1
	470	NC	35	50	0,10	271	217	203	3,5	1,9	AZK471M450NC1
	560	PC	40	50	0,10	227	182	171	4,1	2,3	AZK561M450PC1
		NE	35	75	0,10	227	182	171	4,5	2,5	AZK561M450NE1
	680	NE	35	75	0,10	187	150	141	5,0	2,8	AZK681M450NE1
		PE	40	75	0,10	187	150	141	5,4	3,0	AZK681M450PE1
	1000	PG	40	100	0,10	127	102	96	7,4	4,1	AZK102M450PG1
1200	PG	40	100	0,10	106	85	80	8,1	4,5	AZK122M450PG1	

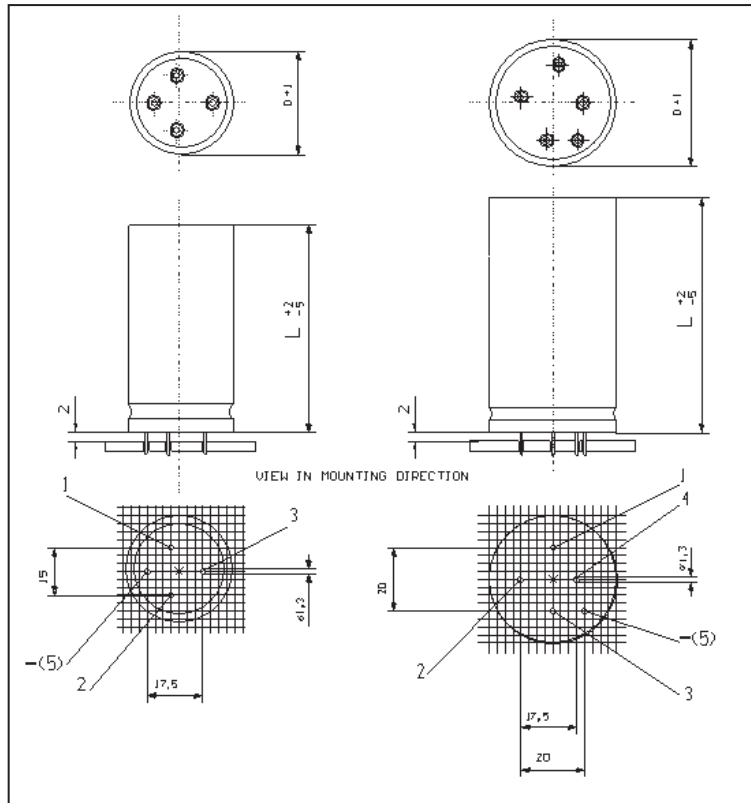
Dimension, Quantity and Weight for box

Case		Connections	Packaging	
Code	DxL	PIN- DIN Type	Pcs/Box	Weight/box
		Number		
NB	35x40	4	100	6-8
NC	35x50	4	100	6-8
NN	35x60	4	100	5-7
NE	35x75	4	50	6-8
PB	40x40	5	100	6-8
PC	40x50	5	100	8-9
PN	40x60	5	100	8-10
PE	40x75	5	50	9-11
PG	40x100	5	50	6-8

All dimensions in mm, torque in Nm, weight in kg