

ARC

Capacitors PCB type

- ARC 2 pins
- Capacitance Tolerance: -20 + 20% - standard (M)
- Self extinguishing construction and electrolyte
- Climatic category: 40/85/56
- Case: 30x40 - 45x100
- Temperature - 25°C + 85°C

Mechanical Outlines

- Case: aluminium made
- Terminals: solder pin
- Sealing: hermetic on Rubber Bakelite cover
- Pressure Release Vent: onto aluminium case
- No insulated bottom
- Sleeve: self-extinguishing thermo shrinkable
- Size: see enclosed drawings
- External Material UL94-V0

Ordering Code: Example

ARC 471 M 400 NC 1

Itelcond Capacitor Series
C: 2 pin

Capacitance: [μF] significant digit plus multiplying factor:
1=x10, 2=x100, 3=x1.000, 4=x10.

1= Sleeve - 0 = not Sleeve
Case Size Code see tables
Voltage - DC rated [V]
Tolerance range:
M=(±20%) X=(-10+30%)

Ripple Current

The allowable values of ripple current in Ampères, are related to the temperature and frequency by following equation:

$$I_{Ripple} = K_t \cdot K_f \cdot I_{Ripple@85^\circ C}$$

Where:

- $I_{Ripple@85^\circ C}$ is the limit given by tables, @ 85°C/100HZ
- K_t is the Temperature Correlation Factor
- K_f is the Frequency Correlation Factor

Note .Superimposed alternating voltage summed to DC volage must not exceed rated voltage, rated ripple current must not be exceeded and no reverse polarity is allowed

°C	40	55	65	75	85
Kt	2.30	1.90	1.70	1.40	1.00

Table 1-Kt Values

	Kf	
Vn/Hz	V<50	V>50
50	0.90	0.88
100	1.00	1.00
300	1.14	1.20
400	1.18	1.25
500	1.20	1.35
>1000	1.25	1.40

Table 2-Kf Values

Expected Lifetime End of Life Criteria

During useful life typical electrical parameters of electrolytic capacitor are subject to change.

End of Life criteria, when rated temperature, voltage and ripple are applied, are:

$$\frac{\Delta C}{C_{t0}} \leq 30\% \quad \text{Equation 1}$$

$$ESR \leq 3 \cdot ESR_{t0} \quad \text{Equation 2}$$

$$I_f \leq I_{ft0} \quad \text{Equation 3}$$

where t_0 is the initial value

Voltage Endurance Test Requirements

Voltage Endurance Test are one of the basys for Expected Lifetime Curves.

End of Life criteria, when rated temperature, and voltage are applied for 2'000hrs, are

$$\frac{\Delta C}{C_{t0}} \leq 10\% \quad \text{Equation 4}$$

$$ESR \leq 1,3 \cdot ESR_{t0} \quad \text{Equation 5}$$

$$I_f \leq I_{ft0} \quad \text{Equation 6}$$

where t_0 is the initial value

Expected Lifetime Vs Temperature and Ripple Current

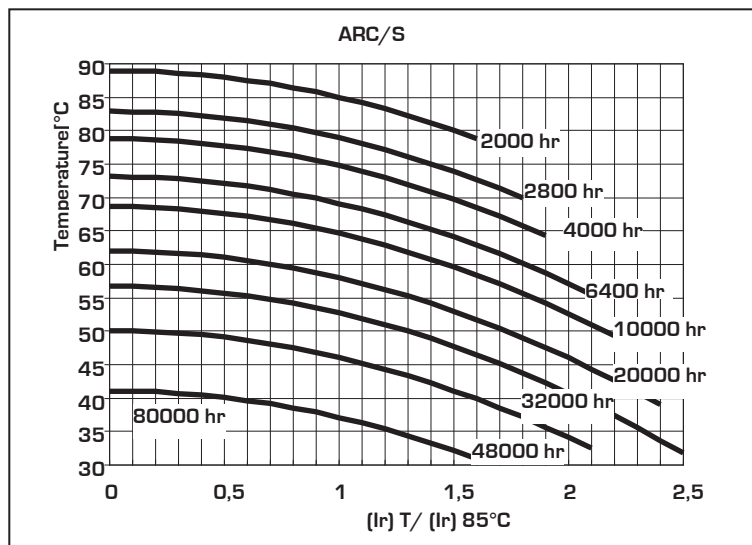

Table 3

Leakage Current

After the rated voltage has been applied to the capacitor for 5 minutes the leakage current must be within those limits.

Maximum limit	@25°C	$I_f \leq 0,006 \times C \times V$
Operating limit	@25°C	$I_f \leq 0,003 \times C \times V$

Where: I_f =leakage current [μA], C =capacitance [μF], V =rated voltage [V]

Surge Voltage

Working Voltage	200	250	350	400	450
Surge Voltage	230	290	385	440	495

	Capacitance	Case	Diam	Height	Tan δ	ESRmax typ		Zmax	Iripple @100Hz		Ordering Code
	[μ F]@100Hz		[mm]	[mm]	[%]@100Hz	[m Ω]@100Hz	[m Ω]@10KHz	[A]@55°C	[A]@85°C		
200	470	MB	30	40	0,09	244	195	183	2,4	1,2	ARC471M200MB1
	680	MB	30	40	0,09	169	135	126	2,8	1,5	ARC681M200MB1
	1000	MC	30	50	0,09	115	92	86	3,8	2,0	ARC102M200MC1
		NB	35	40	0,09	115	92	86	3,8	2,0	ARC102M200NB1
	1200	NB	35	40	0,09	96	76	72	4,1	2,2	ARC122M200NB1
	1500	NC	35	50	0,09	76	61	57	5,1	2,7	ARC152M200NC1
1800	NC	35	50	0,09	64	51	48	5,5	2,9	ARC182M200NC1	
250	470	MB	30	40	0,09	244	195	183	2,4	1,2	ARC471M250MB1
	680	MC	30	50	0,09	169	135	126	3,1	1,6	ARC681M250MC1
		NB	35	40	0,09	169	135	126	3,1	1,6	ARC681M250NB1
	1000	NB	35	40	0,09	115	92	86	3,8	2,0	ARC102M250NB1
		NC	35	50	0,09	115	92	86	4,1	2,2	ARC102M250NC1
	1500	PC	40	50	0,09	76	61	57	5,5	2,9	ARC152M250PC1
2200	NE	35	75	0,09	52	42	39	7,3	3,8	ARC222M250NE1	
400	330	MC	30	50	0,10	386	309	290	2,1	1,1	ARC331M400MC1
	470	MC	30	50	0,10	271	217	203	2,5	1,3	ARC471M400MC1
		PB	40	40	0,10	271	217	203	2,6	1,4	ARC471M400PB1
	560	NC	35	50	0,10	227	182	171	2,9	1,5	ARC561M400NC1
	680	NC	35	50	0,10	187	150	141	3,2	1,7	ARC681M400NC1
		PC	40	50	0,10	187	150	141	3,5	1,8	ARC681M400PC1
1000	PE	40	75	0,10	127	102	96	5,0	2,7	ARC102M400PE1	
1200	PE	40	75	0,10	106	85	80	5,5	2,9	ARC122M400PE1	
450	330	MC	30	50	0,13	502	401	376	1,8	1,0	ARC331M450MC1
	470	NC	35	50	0,13	352	282	264	2,4	1,2	ARC471M450NC1
	680	NC	35	50	0,13	244	195	183	2,8	1,5	ARC681M450NC1
		NN	35	60	0,13	244	195	183	3,1	1,6	ARC681M450NN1
		PC	40	50	0,13	244	195	183	3,1	1,6	ARC681M450PC1
	820	NE	35	75	0,13	202	162	151	3,7	2,0	ARC821M450NE1
1000	PE	40	75	0,13	166	132	124	4,4	2,3	ARC102M450PE1	

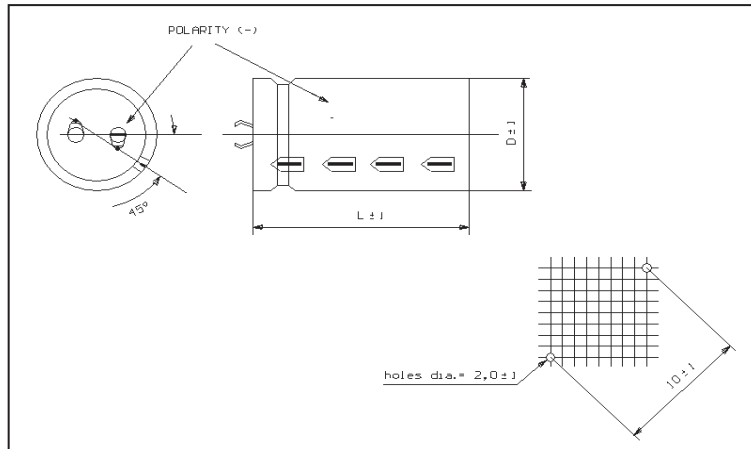
Dimension, Quantity and Weight for box

Case		Connections		Packaging	
Code	DxL	PIN Type		Pcs/Box	Weight/box
		Number	Lenght		
NB	35x40	2	6.3	100	6-8
NC	35x50	2	6.3	100	6-8
NN	35x60	2	6.3	100	5-7
NE	35x75	2	6.3	50	6-8
PB	40x40	2	6.3	100	6-8
PC	40x50	2	6.3	100	8-9
PN	40x60	2	6.3	100	8-10
PE	40x75	2	6.3	50	9-11

All dimensions in mm, torque in Nm, weight in kg