

Revisions

Revisions B-1, B-2, ... On behalf of official Drawing
 Revisions 1, 2, 3, 4, ... On behalf of experiments Drawing

ISS	Symbol	Description	Date
B		CHE for New Drawing Frame & New PN System	2006/07/11
B-1		CHE for Dimension: from $\phi 3.4$ to $\phi 3.2$ CHE for Item 6 Description: from Nut to Cap. Add Dimensions 13 & $\phi 5.4$ on Drawing.	2013/01/23

*Change new drawing frame in Blue Color since 2009/07/01 , to comply with Company CIS Policy.

Note :

- All Metal Materials are in Compliance with RoHS 2 Directive 2011/65/EU Annex III Section 6 Paragraph.
- Recommended Crimped Hand Tool : for Ferrule P/N - **HT-H116N**

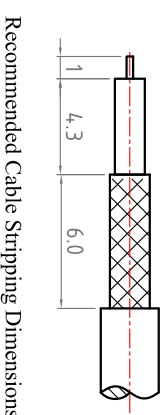
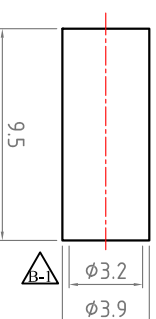
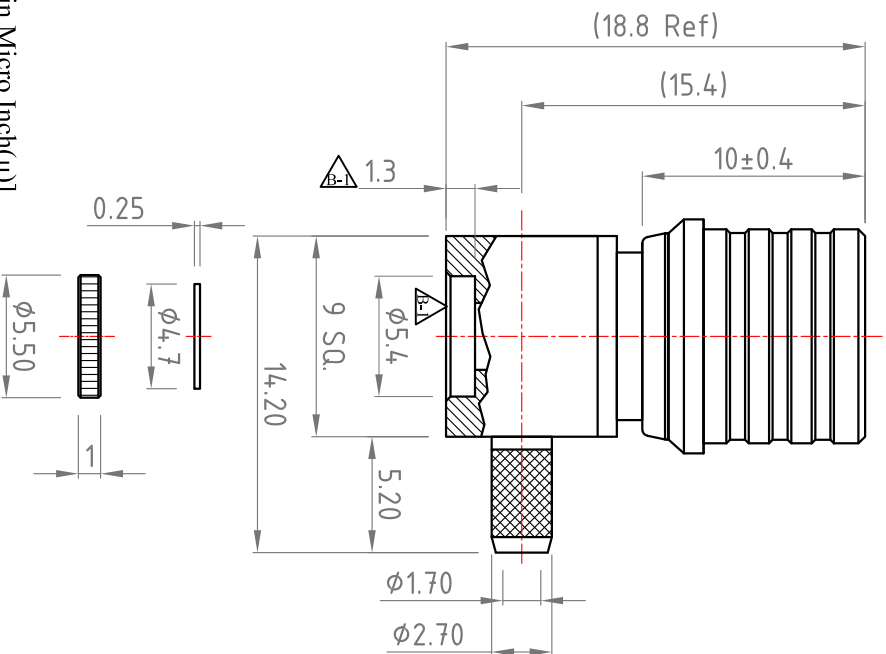

Recommended Cable Stripping Dimensions

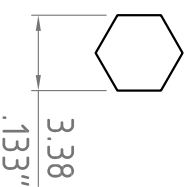

Recommended Crimping
 Dimensions for Ferrule

- Finish : [Plating Thickness Unit in Micro Inch(μ)]
- Nickel Plating Thickness : 80 μ "
 - Gold Plating Thickness : Gold Flash

ITEM	Description	Material	Finish	Part Number	QTY
6	Cap	Brass	Finish 1		
5	Insulator	POM	None		
4	Ferrule	Brass	Finish 1		
3	Pin	Brass	Finish1/2		
2	Insulator	PTFE	None		
1	Body	Brass	Finish 1		

Scale	Abbr.	Date	Rev.
NTS	ST	2013/02/19	B-1

Tolerances :
 .X ± 0.2
 .XX ± 0.1
 .XXX ± 0.05

All Dimensions in mm
 (Unless Otherwise Specified)

Drawn:

Checked:

Approved:

DWG. NO. **QMA-1112d-TGN**

TITLE **QMA R/A Crimp Plug**

Customer P/N: **RG174,188,316;B7805A;URM95 Cable**