

# PRECISION LOW G-SENSITIVITY OCXO MV207

## Features:

- Low G-sensitivity up to:  $0.5 \times 10^{-9} / g$
- Long term stability up to  $\pm 2 \times 10^{-8} / \text{year}$
- High stability vs. temperature: up to  $\pm 7.5 \times 10^{-10}$
- Power supply 5V and 12V
- Package height - down to 12.7 mm
- Frequency range: 5.0 – 20.0 MHz
- Low phase noise option

Power supply
12V
5V

Package type	
36x27x16 mm	B16
36x27x12.7 mm	B12.7

## ORDERING GUIDE: MV207-C 3 F - 12V - B12.7 - LN - 10.0 MHz

Availability of certain stability vs. operating temperature range (for 10 MHz)		$\pm 5 \times 10^{-9}$	$\pm 3 \times 10^{-9}$	$\pm 2 \times 10^{-9}$	$\pm 1 \times 10^{-9}$	$\pm 7.5 \times 10^{-10}$
		5	3	2	1	075
A	0...+55 °C	A	A	A	A	A
B	- 10...+60 °C	A	A	A	A	C
C	- 20...+70 °C	A	A	A	C	NA
D	- 40...+70 °C	A	A	A	C	NA
EX	- 40...+85 °C	A	A	C	C	NA

Availability of certain aging values for certain frequencies		Standard frequencies					
		5.0 MHz	10.0 MHz	12.8 MHz	13.0 MHz	16.384 MHz	20.0 MHz
H	$\pm 2 \times 10^{-7} / \text{year}$	NA	NA	NA	NA	A	A
G	$\pm 1 \times 10^{-7} / \text{year}$	A	A	A	A	A	C
F	$\pm 5 \times 10^{-8} / \text{year}$	A	A	A	A	C	NA
E	$\pm 3 \times 10^{-8} / \text{year}$	A	A	A	C	NA	NA
D	$\pm 2 \times 10^{-8} / \text{year}$	A	A	C	NA	NA	NA

A – available, NA – not available, C – consult factory

Phase noise, dBc/Hz, for 10MHz		LN
		For 12V
1 Hz	<-95	<-100
10 Hz	<-125	<-130
100 Hz	<-145	<-153
1000 Hz	<-150	<-158
10000 Hz	<-155	<-160

## Package drawings:

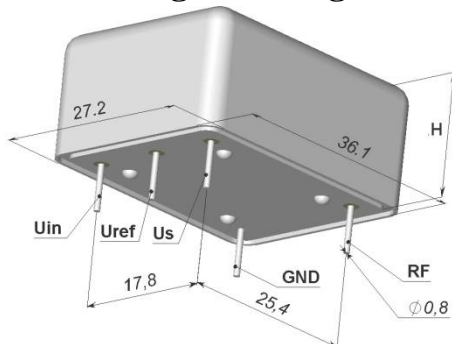

For "H" definition please see package type

<b>Vibrations:</b>	
Frequency range	10-500 Hz
Acceleration	5 g
<b>Shock:</b>	
Acceleration	75 g
Duration	3ms±1
Humidity @ 25 °C	98%
Storage temperature range	-55...+85 °C

\* - for the oscillators with the lower operating temperatures >-20°.

Short term stability (Allan deviation) per 1 sec, for 10 MHz	< $5 \times 10^{-12}$
Optional	< $2 \times 10^{-12}$
G-sensitivity (in frequency range 0-500 Hz)	< $1.5 \times 10^{-9} / g$
Optional	< $1 \times 10^{-9} / g$ < $0.5 \times 10^{-9} / g$
Frequency stability vs. load changes (±5%)	< $± 5 \times 10^{-10}$
Frequency stability vs. power supply changes (±5%)	< $± 5 \times 10^{-10}$
Warm-up time within accuracy of < $± 2 \times 10^{-8}$ @ 25°C	<5 min

Power supply (Us)	12V±5%	5V±5%
Steady state current consumption @ +25°C (for 10 MHz)	<150 mA	<400 mA
Peak current consumption during warm-up *	<400 mA	<1000 mA
Frequency pulling range (for 10 MHz)	> $± 4.0 \times 10^{-7}$	
Control voltage range (Uin)	0...5 V	0...4.5V
Reference voltage (Uref)	+5 V	+4.5 V

Output	SIN
Level	>300 mV RMS
Load	50 Ohm±5%
Harmonics	>30 dBc

## Additional notes:

- For non standard operating temperature ranges please use the following two letters designations (first letter for the lower limit, second letter for the upper limit), °C:

A	B	C	D	E	F	G	H	J	K	L	M	N	P	Q	R	S	T	U	W	X
-60	-55	-50	-45	-40	-30	-20	-10	0	+10	+30	+40	+45	+50	+55	+60	+65	+70	+75	+80	+85