

## High Energy Tantalum Hybrid Capacitor With Mounting Flange - HTHC2F Series

### ◆Features:

1. Full tantalum shell, gas sealing, cylindrical, co directional lead out, polarized.
2. The product is a hybrid capacitor composed of tantalum electrolytic capacitors and electrochemical capacitors, which is the first innovative product in China.
3. Excellent and stable electrical performance, high reliability, long life, high energy density per unit volume, small size, and easy installation.
4. In the energy conversion circuit, it can act as a battery, providing functions such as energy storage and power-off delay for the circuit.



### ◆Specifications:

1. Operating Temperature Range: -55°C~ +125°C. For the Derated Design please see guide line on page 3~5
2. Capacitance Tolerance: Q: -10% ~ +30%, K: ± 10%, M: ± 20%
3. Storage temperature: -62°C ~ +130 °C

### ◆Electrical Characteristics

**Table 1 Rated Voltage, Category Voltage, Surge Voltage, Nominal Capacitance and Main Features**

Rated Voltage(V)	Category Voltage(V)	Surge Voltage(V)	Nominal Capacitance (μF)	tg δ (%)	ESR (Ω) 1kHz	Leakage Current max(μA)			Impedance max (Ω) 100Hz		Capacitance Variation(%)		Max Weight (g)
						25°C	85°C	125°C	-55°C	-55°C	85°C		
10	6	11	100000	180	0.035	300	1800		1	-80	160	84	
16	9.5	17.6	60000	165	0.035	300	1800		1	-80	160	84	
25	15	27.5	36000	130	0.04	300	1800		1	-75	160	84	
35	20	38.5	24000	95	0.04	300	1800		1	-70	160	84	
50	30	55	12000	65	0.10	300	2400		1.2	-60	120	84	
			16000	70	0.04	400				-55	135	109	
63	38	70	8000	50	0.04	400	2400		1.4	-45	90	84	
80	48	88	5600	40	0.06	500	3000		1.6	-40	90	90	
100	60	110	2400	35	0.08	500	3000		1.8	-30	80	90	
			3800		0.05								
110	66	121	1200	35	0.08	500	3000		2	-25	60	90	
125	75	138	1100	30	0.08	500	3000		2.4	-25	50	90	
			2200		0.075								

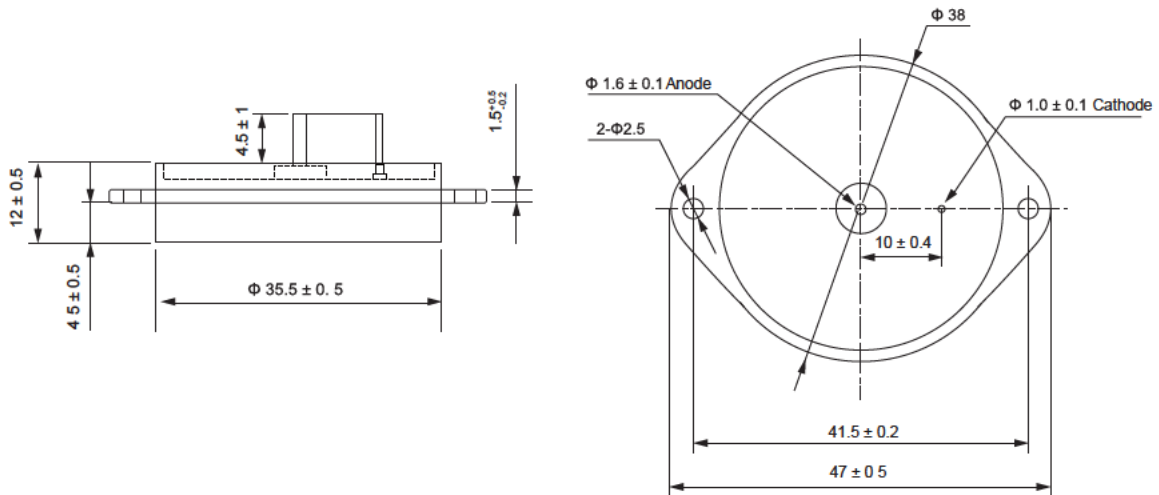

Mounting Dimensional Diagram of HTHC2F  $\Phi 35.5 \times 12$

**Figure 1 Outline Structure and Mounting Dimensional Diagram**

- P.S.:
1. It is prohibited to use a multimeter to measure tantalum capacitors regardless of polarity (it is very easy to cause irreversible damage and lead to product scrapping).
  2. The measurement frequency of capacitance and loss tangent is 100Hz, and the measurement method is equivalent series circuit,  $U_1=2.2^{+0.1}V$ ,  $U_2=1.0^{+0.5}V$  (effective value);
  3. Apply category voltage when measuring 125 °C leakage current; The leakage current parameter is a 5-minute reading;
  4. Pls negotiate with our company if needing products of large capacity or special size exceeding the standard.

## ◆ Derated Design guide line:

### 1. Derating Recommendations

#### 1.1:

The failure rate of tantalum capacitors is for the DC rating (85°C, rated voltage), and varies with usage conditions (ambient temperature, applied voltage, circuit resistance, etc.). In actual circuits, there are often voltage or current peak impulses and ripple currents, or other unexpected electrical impulses, so derating design is necessary in actual use. Only in this way can the safety and reliability of the circuit be

#### 1.2: Rated voltage and derated voltage

The rated voltage (UR) of tantalum capacitors refers to the maximum DC voltage allowed to be applied to the capacitor at a rated temperature of 85°C. If it is used beyond the rated voltage, the dielectric strength of the dielectric oxide film Ta<sub>2</sub>O<sub>5</sub> will be exceeded, which will lead to deterioration of the capacitor performance, and even dielectric breakdown and failure in severe cases.

The environment in which the actual circuit is used is very complex, so in the circuit design, derating design is generally adopted. According to the "Component Derating Criteria" standard, the derating levels of tantalum capacitors are divided into I, II, and III. Class I derating is derated by 50% of the benchmark DC working voltage, class II derating is derated by 60% of the benchmark DC working voltage, and class III derating is derated by 70% of the benchmark DC working voltage.

When the ambient temperature is not more than 85°C, the derated reference DC working voltage is the rated voltage (Ur); when the ambient temperature is more than 85°C, the derated reference DC working voltage is the derated voltage specified in this manual for each model (Ur). Uc). In the derating design, non-solid electrolyte tantalum capacitors and conductive polymer electrolyte tantalum capacitors should be derated at least according to level III. When these two types of tantalum capacitors are used in circuits or filter circuits with high reliability requirements, it is recommended that they should be at least level II Derating; solid electrolyte (manganese dioxide) tantalum capacitors are derated at a minimum of 65% of the reference DC working voltage. When this type of tantalum capacitors are used in circuits or filter circuits with high reliability requirements, it is recommended to derate at least according to class I.

Under the conditions allowed by the design, the derating range should be increased as much as possible. For tantalum capacitors, the larger the derating range, the higher the reliability.

### 2. Reverse voltage

#### 2.1:

The rated voltage (UR) of tantalum capacitors refers to the maximum DC voltage allowed to be applied to the capacitor at a rated temperature of 85°C. If it is used beyond the rated voltage, the dielectric strength of the dielectric oxide film Ta<sub>2</sub>O<sub>5</sub> will be exceeded, which will lead to deterioration of the capacitor performance, and even dielectric breakdown and failure in severe cases.

#### 2.2:

In principle, it is forbidden to use a three-meter electrical barrier to test the circuit with tantalum capacitors or the capacitor itself regardless of polarity (it is easy to apply reverse electricity).

#### 2.3:

In the process of measurement and use, if the tantalum capacitor is accidentally applied to the reverse voltage exceeding the specified value. Even if its electrical parameters are still qualified, the capacitor should be scrapped.

Because the quality hidden danger caused by the reverse voltage of the capacitor has a certain latency period, it may not be manifested at that time.

**Table 1 Recommended voltage for various types of products**

Product Type	Series	Recommended voltage	
		-55°C~85°C	85°C~125°C
Non-Solid Electrolyte Tantalum Capacitors (Tantalum Case)	HCAK38,HCAK39, HCAK39H,HTHC1 etc.	65%U <sub>R</sub>	42%U <sub>R</sub>
Non-solid Electrolyte Tantalum Capacitors (Silver Case)	HCAK35,HCAK86 etc.	65%U <sub>R</sub>	42%U <sub>R</sub>
MnO. Solid Electrolyte Tantalum Capacitors (Metal Case)	HCAK,HCAK- 1 etc.	(50%-60%)U <sub>R</sub>	40% U <sub>R</sub>
Polymer Solid Electrolyte Tantalum Capacitors (Metal Case)	HCAK66 etc.	(50%-60%)U <sub>R</sub>	40% U <sub>R</sub>
MnO. Chip Type Solid Electrolytic Tantalum Capacitor (Molded Plastic Package)	HCAK45,HCAK45L, HCAK45U,HCAK45M etc.	50%U <sub>R</sub>	33%U <sub>R</sub>
Chip Polymer Solid Electrolyte Tantalum Capacitor (Molded Plastic Package)	HCAK55,HCAK55H etc.	50%U <sub>R</sub>	33% U <sub>R</sub>
MnO. Solid Electrolyte Tantalum Capacitors (Molded Plastic)	HCAK44,HCAK41 etc.	50%U <sub>R</sub>	33% U <sub>R</sub>

When the circuit adopts all tantalum capacitors above 35V (including 35V), it should be able to withstand the reverse test of the 1.5V power supply of the three-meter, and the 9V power supply should be absolutely prohibited.

### 3. Influence factors of failure rate

#### 3.1:

The lower the voltage across the actually added tantalum capacitor is lower than the rated voltage, the lower the failure rate of the tantalum capacitor. The failure rate of tantalum capacitors is evaluated under the maximum allowable load conditions at the rated voltage of 85°C.

#### 3.2:

Another factor that affects the failure is the series resistance connected to the outer circuit of the capacitor. The greater the resistance in series with the capacitor in the outer circuit circuit, the lower the failure rate.

Failure rate grade: 2.0%/1000h is expressed as L; 1.0%/1000h is expressed as M; 0.1%/1000h is expressed as P; 0.01%/1000h is expressed as R, 0.001%/1000h is expressed as S.

**Table 2 Reverse voltage resistance of various types of products**

Product Type		Series	Withstand reverse voltage
Non-Solid Electrolyte Tantalum Capacitors	All tantalum capacitors with tantalum case	HCAK38, HCAK39, HCAK38T etc.	Resistant to 3V reverse voltage
	Hybrid Tantalum Capacitors	HTHC1, HTHC2, HTHC1W, HCAK36S1, HCAK36S1W etc.	Not resistant to reverse voltage
	Silver case	HCAK35, HCAK35X, HCAK86, HCAK81 etc.	Not resistant to reverse voltage
Solid Electrolyte Tantalum Capacitors		HCAK, HCAK-1, HCAK-8, HGCA, HGCA411C etc.	<p>Generally, reverse voltage is not allowed, let alone used in pure AC circuits. If it is unavoidable, it is allowed to apply a reverse voltage not greater than the following in a short period of time, and its value is:</p> <p>below 25°C: <math>\leq 10\% U_R</math> or 1V (whichever is smaller);</p> <p>below 85°C: <math>\leq 5\% U_R</math> or 0.5V (whichever is smaller);</p> <p>below 125°C: <math>\leq 1\% U_R</math> or 0.1V (whichever is smaller).</p> <p>Note: If the capacitor needs to work in a circuit with reverse voltage for a long time, please use a bipolar tantalum capacitor, but it can only be used in a DC or pulsating circuit with a low frequency of polarity change.</p>
Polymer Solid Electrolyte Tantalum Capacitors		HCAK66 etc.	Not resistant to reverse voltage
Solid Electrolyte Tantalum Capacitors		HCAK44, HCAK41 etc.	Not resistant to reverse voltage
Chip Tantalum Solid Electrolyte Tantalum Capacitors		HCAK45, HCAK45L, HCAK45U, HCAK45M etc.	Not resistant to reverse voltage
Chip Polymer Solid Electrolyte Tantalum Capacitors		HCAK55, HCAK55H etc.	Not resistant to reverse voltage

Note: Specification is subject to change without further notice. For more details and updates, please visit our website.