

Hybrid Tantalum Capacitor - HTHC1 Series

◆Features:

1. All tantalum shell, airtight, cylindrical, lead out in the same direction, polarized.
2. The product is a hybrid capacitor composed of tantalum electrolytic capacitors and electrochemical capacitors. It is the first innovative product in China with small size and large energy storage.
3. Excellent and stable electrical performance, high reliability, long life, and internal energy per unit volume.
4. Can act as a battery in the energy conversion circuit, providing storage for the circuit function, power-off delay and so on.
5. A represents the lead form, including type A and type B.

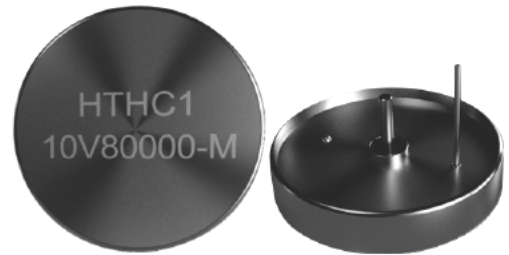

◆Specifications:

1. Operating Temperature Range: -55°C~ +125°C. For the Derated Design please see guide line on page 4-6
2. Capacitance Tolerance: Q: -10% ~ +30%, K: ± 10%, M: ± 20%
3. Storage temperature: -62°C ~ +130 °C

◆Electrical Characteristics

Table 1 Rated Voltage, Category Voltage, Surge Voltage, Nominal Capacitance and Main Features

Rated Voltage(V)	Category Voltage(V)	Surge Voltage(V)	Nominal Capacitance (μF)	tg δ (%)	ESR (Ω) 1kHz	Leakage Current max(μA)			Impedance max (Ω) 100Hz	Capacitance Variation(%)		Dimension D X H (mm)	Max Weight (g)
						25°C	85°C	125°C		55°C	85°C		
10	6	11	8000	80	0.3	100	600	125°C	8	-80	160	22x8	28
16	9.5	17.6	7000	70	0.3	125	750	125°C	8	-80	160	22x8	28
25	15	27.5	5000	60	0.3	150	900	125°C	8	-75	150	22x8	28
35	20	38.5	3500	50	0.3	150	900	125°C	8	-70	140	22x8	28
50	30	55	2500	46	0.3	155	930	125°C	9.6	-60	120	22x8	28
63	38	70	1200	35	0.4	85	510	125°C	11.2	-50	80	22x8	28
80	48	88	860	30	0.4	90	540	125°C	12.8	-40	80	22x8	28
100	60	110	400	25	0.5	25	150	125°C	14.4	-30	60	22x8	28
110	66	121	200	20	0.5	25	150	125°C	16	-25	50	22x8	28
125	75	138	160	20	0.6	25	150	125°C	19.2	-20	50	22x8	28

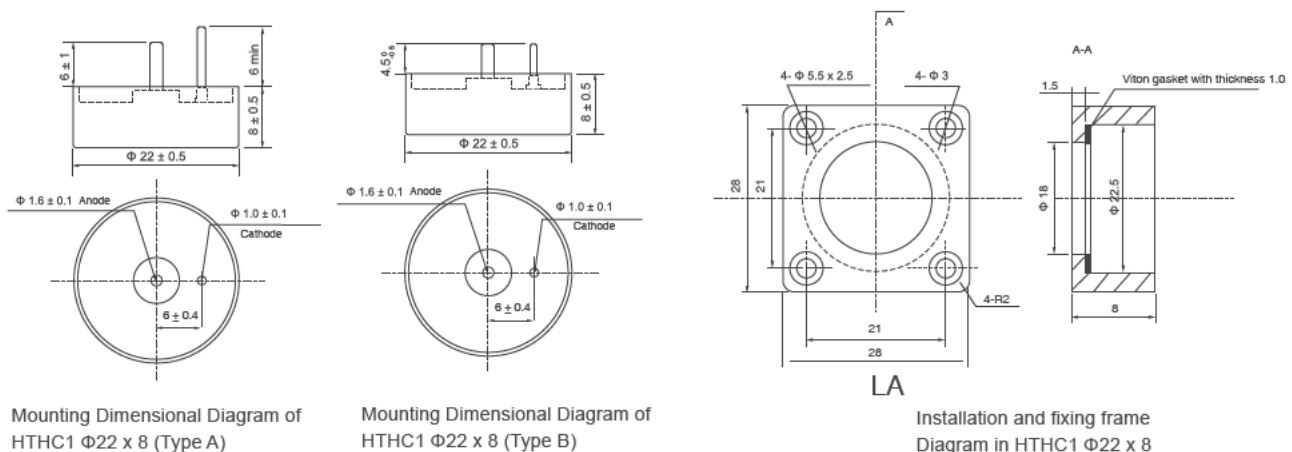
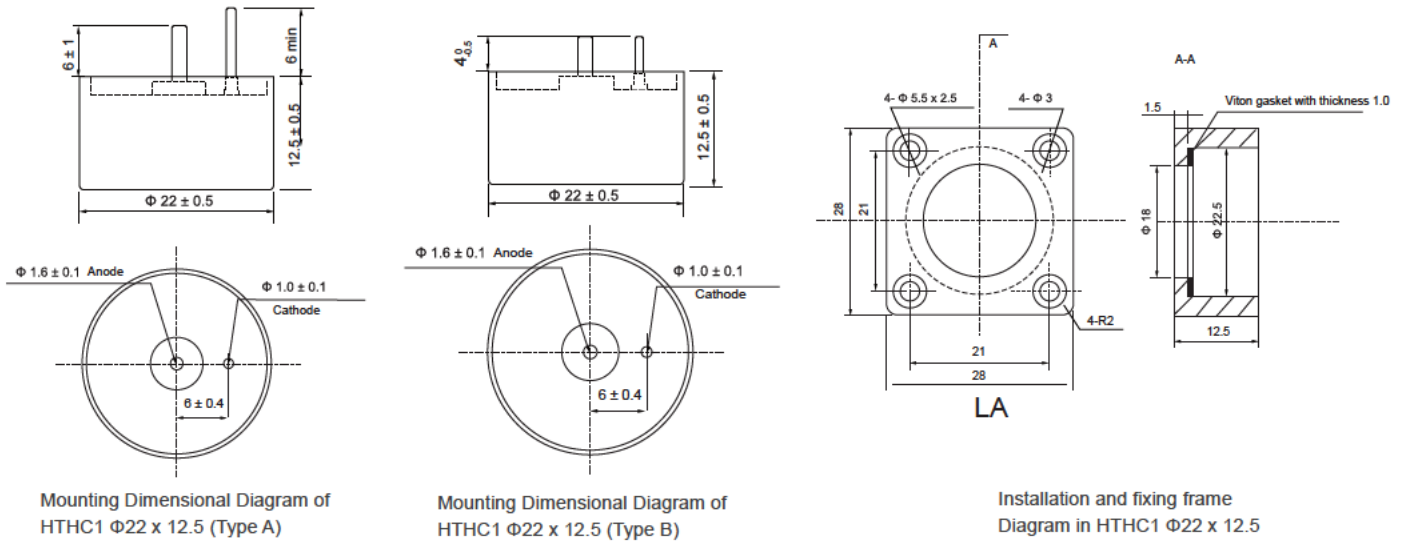

Figure 1 Outline Structure and Mounting Dimensional Diagram

Table 2 Rated Voltage, Category Voltage, Surge Voltage, Nominal Capacitance and Main Features

Rated Voltage(V)	Category Voltage(V)	Surage Voltage(V)	Nominal Capacitance (μF)	tg δ (%)	ESR (Ω) 1kHz	Leakage Current max(μA)			Impedance max (Ω) 100Hz	Capacitance Variation(%)		Dimension D X H (mm)	Max Weight (g)
						25°C	85°C	125°C	55°C	55°C	85°C		
10	6	11	20000	90	0.1	150	900	2.5	-80	160	22×12.5	35	
16	9.5	17.6	18000	80	0.1	150	900	2.5	-80	160	22×12.5	35	
25	15	27.5	13000	70	0.1	150	900	2.5	-75	150	22×12.5	35	
35	20	38.5	9000	60	0.1	170	1000	2.5	-70	140	22×12.5	35	
50	30	55	6800	65	0.1	170	1000	1.2	-45	120	22×12.5	35	
63	38	70	2800	55	0.2	170	1000	3.5	-50	80	22×12.5	35	
80	48	88	2000	45	0.2	200	1200	3.5	-40	80	22×12.5	35	
100	60	110	1000	40	0.2	200	1200	4	-30	60	22×12.5	38	
110	66	121	800	30	0.2	200	1200	4	-25	50	22×12.5	38	
125	75	138	600	30	0.3	200	1200	4	-20	50	22×12.5	38	

Figure 2 Outline Structure and Mounting Dimensional Diagram
Table 3 Rated Voltage, Category Voltage, Surge Voltage, Nominal Capacitance and Main Features

Rated Voltage(V)	Category Voltage(V)	Surage Voltage(V)	Nominal Capacitance (μF)	tg δ (%)	ESR (Ω) 1kHz	Leakage Current max(μA)			Impedance max (Ω) 100Hz	Capacitance Variation(%)		Dimension D X H (mm)	Max Weight (g)
						25°C	85°C	125°C	55°C	55°C	85°C		
10	6	11	50000	180	0.05	150	900	1	-75	140	35.5×8	52	
16	9.5	17.6	30000	160	0.05	150	900	1	-70	140	35.5×8	52	
25	15	27.5	18000	120	0.05	150	900	1	-65	120	35.5×8	52	
35	20	38.5	12000	90	0.065	150	900	1	-50	120	35.5×8	52	
50	30	55	8000	65	0.07	170	1000	1.2	-40	120	35.5×8	52	
50	30	55	9000	65	0.07	170	1000	1.2	-45	120	35.5×8	52	
63	38	70	1800	40	0.2	126	1000	1.4	-20	60	35.5×8	52	
63	38	70	4000	45	0.1	170	1000	1.4	-30	80	35.5×8	52	
80	48	88	1600	20	0.15	100	1000	1.6	-20	60	35.5×8	55	
80	48	88	2800	40	0.1	200	1200	1.6	-30	80	35.5×8	55	
100	60	110	1200	35	0.125	200	1200	1.8	-25	60	35.5×8	55	
100	60	110	1900	35	0.125	200	1200	1.8	-25	60	35.5×8	55	
110	66	121	580	35	0.2	200	1200	2	-20	50	35.5×8	55	
110	66	121	1500	35	0.2	200	1200	2	-20	50	35.5×8	55	
125	75	138	560	35	0.2	200	1200	2.4	-15	50	35.5×8	55	
125	75	138	1100	35	0.2	200	1200	2.4	-15	50	35.5×8	55	

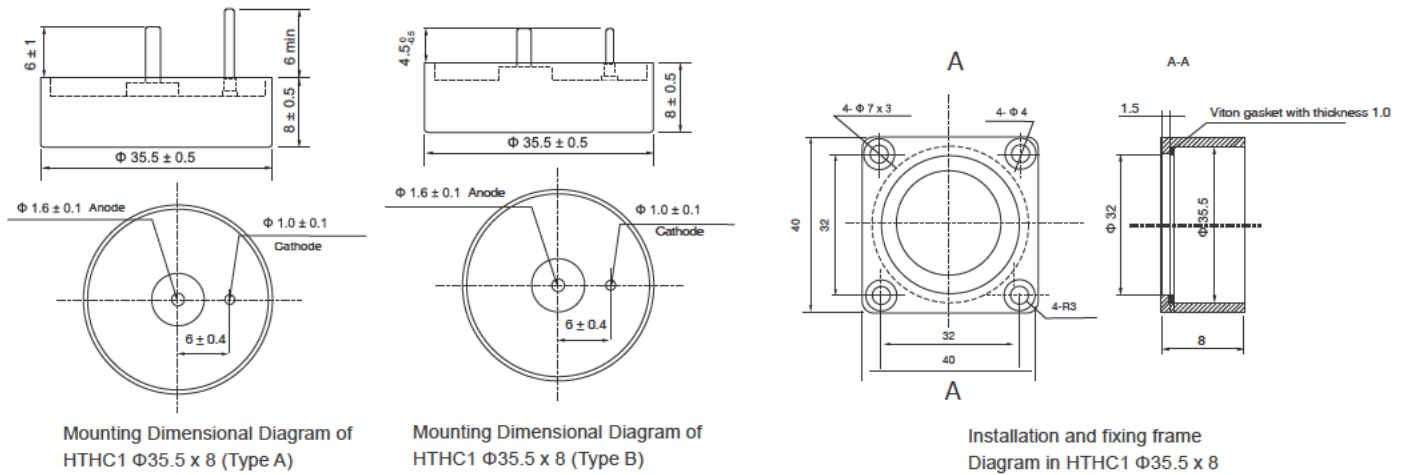

Figure 3 Outline Structure and Mounting Dimensional Diagram

- P.S.: 1. It is forbidden to use a multimeter to measure tantalum capacitors regardless of polarity;
2. The measurement frequency of capacitance and loss tangent is 100Hz, and the measurement method is equivalent series circuit, $U_2=2.2^{+0.1}V$, $U_1=1.0^{+0.5}V$ (effective value);
3. When measuring the leakage current at 125°C, please apply a category voltage; the leakage current parameter is a 5-minute reading;
4. Products with large capacity or special sizes exceeding this standard can be produced through negotiation with our company.

◆ Derated Design guide line:

1. Derating Recommendations

1.1:

The failure rate of tantalum capacitors is for the DC rating (85°C, rated voltage), and varies with usage conditions (ambient temperature, applied voltage, circuit resistance, etc.). In actual circuits, there are often voltage or current peak impulses and ripple currents, or other unexpected electrical impulses, so derating design is necessary in actual use. Only in this way can the safety and reliability of the circuit be

1.2: Rated voltage and derated voltage

The rated voltage (UR) of tantalum capacitors refers to the maximum DC voltage allowed to be applied to the capacitor at a rated temperature of 85°C. If it is used beyond the rated voltage, the dielectric strength of the dielectric oxide film Ta₂O₅ will be exceeded, which will lead to deterioration of the capacitor performance, and even dielectric breakdown and failure in severe cases.

The environment in which the actual circuit is used is very complex, so in the circuit design, derating design is generally adopted. According to the "Component Derating Criteria" standard, the derating levels of tantalum capacitors are divided into I, II, and III. Class I derating is derated by 50% of the benchmark DC working voltage, class II derating is derated by 60% of the benchmark DC working voltage, and class III derating is derated by 70% of the benchmark DC working voltage.

When the ambient temperature is not more than 85°C, the derated reference DC working voltage is the rated voltage (Ur); when the ambient temperature is more than 85°C, the derated reference DC working voltage is the derated voltage specified in this manual for each model (Ur). Uc). In the derating design, non-solid electrolyte tantalum capacitors and conductive polymer electrolyte tantalum capacitors should be derated at least according to level III. When these two types of tantalum capacitors are used in circuits or filter circuits with high reliability requirements, it is recommended that they should be at least level II Derating; solid electrolyte (manganese dioxide) tantalum capacitors are derated at a minimum of 65% of the reference DC working voltage. When this type of tantalum capacitors are used in circuits or filter circuits with high reliability requirements, it is recommended to derate at least according to class I.

Under the conditions allowed by the design, the derating range should be increased as much as possible. For tantalum capacitors, the larger the derating range, the higher the reliability.

2. Reverse voltage

2.1:

The rated voltage (UR) of tantalum capacitors refers to the maximum DC voltage allowed to be applied to the capacitor at a rated temperature of 85°C. If it is used beyond the rated voltage, the dielectric strength of the dielectric oxide film Ta₂O₅ will be exceeded, which will lead to deterioration of the capacitor performance, and even dielectric breakdown and failure in severe cases.

2.2:

In principle, it is forbidden to use a three-meter electrical barrier to test the circuit with tantalum capacitors or the capacitor itself regardless of polarity (it is easy to apply reverse electricity).

2.3:

In the process of measurement and use, if the tantalum capacitor is accidentally applied to the reverse voltage exceeding the specified value. Even if its electrical parameters are still qualified, the capacitor should be scrapped.

Because the quality hidden danger caused by the reverse voltage of the capacitor has a certain latency period, it may not be manifested at that time.

Table 1 Recommended voltage for various types of products

Product Type	Series	Recommended voltage	
		-55°C~85°C	85°C~125°C
Non-Solid Electrolyte Tantalum Capacitors (Tantalum Case)	HCAK38,HCAK39, HCAK39H,HTHC1 etc.	65%U _R	42%U _R
Non-solid Electrolyte Tantalum Capacitors (Silver Case)	HCAK35,HCAK86 etc.	65%U _R	42%U _R
MnO. Solid Electrolyte Tantalum Capacitors (Metal Case)	HCAK,HCAK- 1 etc.	(50%-60%)U _R	40% U _R
Polymer Solid Electrolyte Tantalum Capacitors (Metal Case)	HCAK66 etc.	(50%-60%)U _R	40% U _R
MnO. Chip Type Solid Electrolytic Tantalum Capacitor (Molded Plastic Package)	HCAK45,HCAK45L, HCAK45U,HCAK45M etc.	50%U _R	33%U _R
Chip Polymer Solid Electrolyte Tantalum Capacitor (Molded Plastic Package)	HCAK55,HCAK55H etc.	50%U _R	33% U _R
MnO. Solid Electrolyte Tantalum Capacitors (Molded Plastic)	HCAK44,HCAK41 etc.	50%U _R	33% U _R

When the circuit adopts all tantalum capacitors above 35V (including 35V), it should be able to withstand the reverse test of the 1.5V power supply of the three-meter, and the 9V power supply should be absolutely prohibited.

3. Influence factors of failure rate

3.1:

The lower the voltage across the actually added tantalum capacitor is lower than the rated voltage, the lower the failure rate of the tantalum capacitor. The failure rate of tantalum capacitors is evaluated under the maximum allowable load conditions at the rated voltage of 85°C.

3.2:

Another factor that affects the failure is the series resistance connected to the outer circuit of the capacitor. The greater the resistance in series with the capacitor in the outer circuit circuit, the lower the failure rate.

Failure rate grade: 2.0%/1000h is expressed as L; 1.0%/1000h is expressed as M; 0.1%/1000h is expressed as P; 0.01%/1000h is expressed as R, 0.001%/1000h is expressed as S.

Table 2 Reverse voltage resistance of various types of products

Product Type		Series	Withstand reverse voltage
Non-Solid Electrolyte Tantalum Capacitors	All tantalum capacitors with tantalum case	HCAK38, HCAK39, HCAK38T etc.	Resistant to 3V reverse voltage
	Hybrid Tantalum Capacitors	HTHC1, HTHC2, HTHC1W, HCAK36S1, HCAK36S1W etc.	Not resistant to reverse voltage
	Silver case	HCAK35, HCAK35X, HCAK86, HCAK81 etc.	Not resistant to reverse voltage
Solid Electrolyte Tantalum Capacitors		HCAK, HCAK-1, HCAK-8, HGCA, HGCA411C etc.	<p>Generally, reverse voltage is not allowed, let alone used in pure AC circuits. If it is unavoidable, it is allowed to apply a reverse voltage not greater than the following in a short period of time, and its value is:</p> <p>below 25°C: $\leq 10\% U_R$ or 1V (whichever is smaller);</p> <p>below 85°C: $\leq 5\% U_R$ or 0.5V (whichever is smaller);</p> <p>below 125°C: $\leq 1\% U_R$ or 0.1V (whichever is smaller).</p> <p>Note: If the capacitor needs to work in a circuit with reverse voltage for a long time, please use a bipolar tantalum capacitor, but it can only be used in a DC or pulsating circuit with a low frequency of polarity change.</p>
Polymer Solid Electrolyte Tantalum Capacitors		HCAK66 etc.	Not resistant to reverse voltage
Solid Electrolyte Tantalum Capacitors		HCAK44, HCAK41 etc.	Not resistant to reverse voltage
Chip Tantalum Solid Electrolyte Tantalum Capacitors		HCAK45, HCAK45L, HCAK45U, HCAK45M etc.	Not resistant to reverse voltage
Chip Polymer Solid Electrolyte Tantalum Capacitors		HCAK55, HCAK55H etc.	Not resistant to reverse voltage

Note: Specification is subject to change without further notice. For more details and updates, please visit our website.