

# PRECISION OCXO IN SMD PACKAGE MV140

## Features:

- High frequency stability vs. temperature - up to  $\pm 5.0 \times 10^{-9}$
- Standard 25x22 mm SMD package
- Oven alarm & oscillator On/Off function
- Available as RoHS
- Frequency range: 10 – 20 MHz

## ORDERING GUIDE: MV140-B 20 F - 10.0 MHz - 1

Availability of certain stability vs. operating temperature range		$\pm 5 \times 10^{-8}$	$\pm 2 \times 10^{-8}$	$\pm 1 \times 10^{-8}$	$\pm 5 \times 10^{-9}$
		50	20	10	5
A	0...+55 °C	A	A	A	A
B	-10...+60 °C	A	A	A	A
C	-20...+70 °C	A	A	A	A
D	-40...+70 °C	A	A	A	C
EX	-40...+85 °C	A	C	NA	NA

A – available, NA – not available, C – consult factory

For other temperature ranges see designation at the end of Data Sheet.

Availability of certain aging values for certain frequencies		Standard frequencies, MHz				
		10.0	12.8	13.0	16.384	20.0
H	$\pm 2.0 \times 10^{-7}$ /year	A	A	A	A	A
G	$\pm 1.0 \times 10^{-7}$ /year	A	A	A	A	C
F	$\pm 5.0 \times 10^{-8}$ /year	A	A	A	C	NA
E	$\pm 3.0 \times 10^{-8}$ /year	A	C	C	NA	NA

A – available, NA – not available, C – consult factory

## Package drawing:

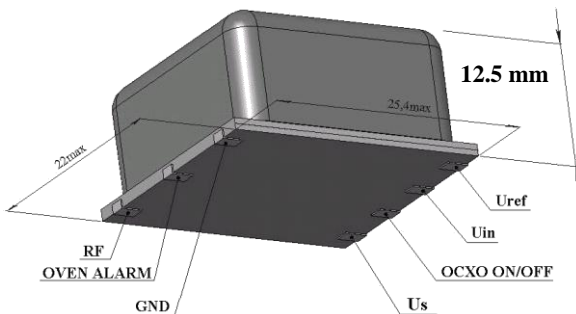

	1	2	3
Short term stability (Allan deviation) per 1 sec, for 10 MHz	$< 5 \times 10^{-12}$	$< 5 \times 10^{-11}$	$< 5 \times 10^{-10}$
Frequency stability vs. load changes	$< \pm 2 \times 10^{-10}$	$< \pm 2 \times 10^{-9}$	$< \pm 5 \times 10^{-9}$
Frequency stability vs. power supply changes	$< \pm 2 \times 10^{-10}$	$< \pm 2 \times 10^{-9}$	$< \pm 5 \times 10^{-9}$
Power supply (Us)	12V $\pm$ 5%		
Current maximum value @ 25°C	360 mA		
Warm-up time within $< \pm 1 \times 10^{-7}$ @ 25 °C	<3 min		
Frequency pulling range with external voltage range (Uin)	$> \pm 5 \times 10^{-7}$		
Reference voltage output (Uref)	+5 V		
Output	SIN		
Level	$> 400$ mV		
Load	50 Ohm		
Phase noise, (for 10 MHz) , dBc/Hz			
1 Hz	$< -100$	$< -90$	$< -80$
10 Hz	$< -130$	$< -120$	$< -110$
100 Hz	$< -145$	$< -140$	$< -135$
1000 Hz	$< -150$	$< -150$	$< -145$
10000 Hz	$< -155$	$< -155$	$< -155$

Vibrations:	
Frequency range	10-500 Hz
Acceleration	10g
Shock:	
Acceleration	100 g
Storage temperature range	-55...+85 °C

## Additional notes:

- Showed values of frequency stability vs. temperature usually are tested in Still Air test conditions. Please inform factory about different conditions in operation to provide appropriate tests.
- For non standard operating temperature ranges please use the following two letters designations (first letter for the lower limit, second letter for the upper limit), °C:

A	B	C	D	E	F	G	H	J	K	L	M	N	P	Q	R	S	T	U	W	X
-60	-55	-50	-45	-40	-30	-20	-10	0	+10	+30	+40	+45	+50	+55	+60	+65	+70	+75	+80	+85