

HIGH STABILITY SMALL SIZE OCXO MV103

Features:

- Small size
- 5V or 12V power supply
- Available as RoHS
- Frequency range 10.0-40.0 MHz

Output	Power Supply
SIN	12 V
HCMOS	5 V

ORDERING GUIDE: MV103 – B 20G – SIN – 12V – 10.0 MHz

Availability of certain stability vs. operating temperature range		$\pm 5 \times 10^{-8}$	$\pm 2 \times 10^{-8}$	$\pm 1 \times 10^{-8}$	$\pm 7.5 \times 10^{-9}$
		50	20	10	7
A	0...+55 °C	A	A	A	C
B	-10...+60 °C	A	A	A	C
C	-20...+70 °C	A	A	A	C
D	-40...+70 °C	A	A	C	NA
EX	-40...+85 °C	A	C	C	NA

A – available, NA – not available, C – consult factory

For other temperature ranges see designation at the end of Data Sheet.

Availability of certain aging values for certain frequencies		Standard frequencies			
		10.0 MHz	12.8 MHz	13.0 MHz	16.384 MHz
		Multiplied frequencies			
		20.0 MHz	25.6 MHz	26.0 MHz	32.768 MHz
H	$\pm 2 \times 10^{-7}$ /year	A	A	A	A
G	$\pm 1 \times 10^{-7}$ /year	A	A	A	A
F	$\pm 5 \times 10^{-8}$ /year	A	A	A	C
E	$\pm 3 \times 10^{-8}$ /year	A	C	C	NA

A – available, NA – not available, C – consult factory

Package drawing:

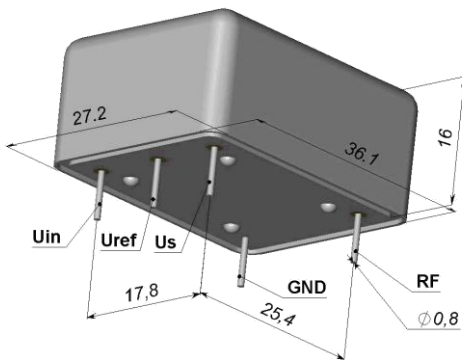

Mechanical characteristics:

Vibrations:	
Frequency range	10-500 Hz
Acceleration	10g
Shock:	
Acceleration	100 g
Duration	3±1 ms
Storage temperature range	-55...+85 °C

Frequency stability vs. load changes	$< \pm 5 \times 10^{-9}$	
Frequency stability vs. power supply changes	$< \pm 5 \times 10^{-9}$	
Power supply (Us)	5V±5%	12V±5%
Current consumption at steady state @ 25°C	<200 mA	<80 mA
Peak current consumption during warm-up	<600 mA	<300 mA
Reference voltage output (Uref)	+4.5 V	+5V
Warm-up time within $< \pm 1 \times 10^{-7}$ @ 25 °C	<3 min	
Frequency pulling range	$> \pm 5 \times 10^{-7}$	
with external voltage range (Uin)	0...+4.5 V	0...+5 V
or with external potentiometer	20 kOhm	

Preferable frequencies: 10 MHz; 12,8 MHz; 13 MHz; 15,36 MHz; 16 MHz; 16,384 MHz; 20 MHz; 26 MHz; 30,72 MHz; 32 MHz; 32,768 MHz							
Frequency range, MHz	10-13	>13-20	>20-40	10-13	>13-20	>20-40	
Output	HCMOS			SIN			
Level	-			> 225 mV			
Harmonics/Subharmonics	-			< -30 dBc			
Level High/Low	>4,0/<0,4			-/-			
Duty factor	45...55%			-			
Phase noise, typical, at	1 Hz	-90	-75	-70	-90	-75	-70
	10 Hz	-120	-105	-100	-120	-105	-100
	100 Hz	-140	-135	-125	-140	-135	-125
	1000 Hz	-145	-145	-135	-150	-150	-140
	10000 Hz	-150	-150	-140	-155	-150	-145
Short term stability (Allan deviation) per 1 sec, $\times 10^{-11}$	<1	<2	<3	<1	<2	<3	

Additional notes:

- Showed values of frequency stability vs. temperature usually are tested in Still Air test conditions. Please inform factory about different conditions in operation to provide appropriate tests.
- For non standard operating temperature ranges please use the following two letters designations (first letter for the lower limit, second letter for the upper limit), °C:

A	B	C	D	E	F	G	H	J	K	L	M	N	P	Q	R	S	T	U	W	X
-60	-55	-50	-45	-40	-30	-20	-10	0	+10	+30	+40	+45	+50	+55	+60	+65	+70	+75	+80	+85