

SN -30W Series

30W 2:1 Regulated Single & Dual output

Features

- Ultra Wide 2:1 Input Range
- 1600 VDC Isolation
- No Minimum Load Required
- Efficiency up to 92%
- Extended Operating Temperature Range -40 ~ 100°C max.
- Adjustable Output Voltage
- Remote On/Off Control (CTRL)
- Continuous Short Circuit Protection
- Over Current Protection
- Over Voltage Protection
- Over Temperature Protection
- Soft Start

The SN series is a family of cost effective 30W single & dual output DC-DC converters. These converters combine copper package in a 1"x1" case with high performance features, continuous short circuit protection with automatic restart and tight line / load regulation. Devices are encapsulated using flame retardant resin. Input voltages of 12,24 and 48 with output voltage of 3.3, 5, 12, 15, ± 12 , ± 15 Vdc. High performance features include high efficiency operation up to 92% and output voltage accuracy of $\pm 1\%$ maximum.

ALL SPECIFICATIONS ARE TYPICAL AT 25°C, NOMINAL INPUT AND FULL LOAD UNLESS OTHERWISE NOTED.

SCHMID-M

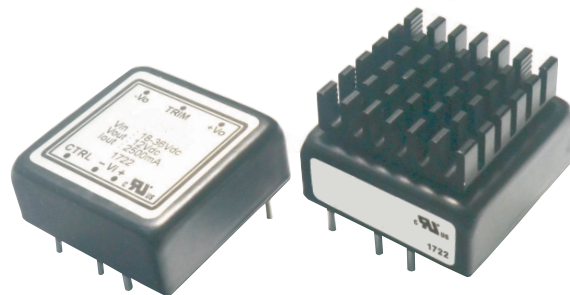

OUTPUT SPECIFICATIONS	
Output Voltage Accuracy	$\pm 1\%$
Output Voltage Adjustability(Trim)	Single output: $\pm 10\%$, max.
Maximum Output Current	See table
Line Regulation	$\pm 0.5\%$, max.
Load Regulation($I_o=0\%$ to 100%)	Single: $\pm 0.5\%$, max. Dual: $\pm 1\%$, max.(balanced load)
Cross Regulation (Dual Output) (1)	$\pm 5\%$
Ripple&Noise	
Measured by 20MHz bandwidth	
With a 10uF/25V X7R MLCC	Single output:75mVpk-pk,max.
With a 10uF/25V X7R MLCC for each output	dual output:60mVpk-pk,max.
Over Voltage Protection (Zener diode clamp)	3.3V output 3.9V 5V output 6.2V 12V output 15V 15V output 18V ± 12 V output ± 15 V ± 15 V output ± 18 V
Over Current Protection	150% of FL, typ.
Short Circuit Protection	Indefinite(hiccup) (Automatic Recovery)
Temperature Coefficient	$\pm 0.02\%/^{\circ}\text{C}$
Capacitive Load (2)	See table
Transient Recovery Time (3)	250us, typ.
Transient Response Deviation(3)	$\pm 3\%$, max. Single Output 3.3V: $\pm 5\%$,max.

INPUT SPECIFICATIONS	
Input Voltage Range	See table
Under Voltage Lockout	
12V Models	Module ON / OFF 8.6Vdc / 7.9Vdc, typ.
24V Models	Module ON / OFF 17.8Vdc / 16.5Vdc, typ.
48V Models	Module ON / OFF 34Vdc / 32.5Vdc, typ.
Start up Time (Nominal V_{in} and constant resistive load)	30mS, typ.
Input Filter	Pi Type
Input Current(No-Load)	See table, max.
Input Current(Full-Load)	See table, typ.
Input Reflected Ripple Current(4)	30mA _{p-p} , typ.
Remote On/Off (Positive logic)(5)	
ON:	3.0 ... 12Vdc or open circuit
OFF:	0 ... 1.2Vdc or Short circuit pin2 and pin 3
OFF idle current:	2 mA, typ.

GENERAL SPECIFICATIONS	
Efficiency	See table, typ.
I/O Isolation Voltage(60sec)	
Input/Output	1600Vdc
Case/Input & Output	1600Vdc
Isolation Resistance	1000 M Ω , min.
Isolation Capacitance	2000 pF, max.
Switching Frequency	
3.3 & 05 Vout Models	270kHz, typ.
other Models	330kHz, typ.
Humidity	95% rel H
Reliability Calculated MTBF(MIL-HDBK-217 F)	>370 Khrs
Safety Standard	UL/cUL 60950-1, 62368-1 IEC/EN 60950-1, 62368-1
Safety Approvals	UL/cUL 60950-1, 62368-1 IEC/EN 60950-1, 62368-1
ABSOLUTE SPECIFICATIONS (6)	
These are stress ratings. Exposure of devices to any of these conditions may adversely affect long-term reliability.	
Input Surge Voltage(100mS)	
12 Models	25 Vdc, max.
24 Models	50 Vdc, max.
48 Models	100 Vdc, max.
Soldering Temperature(1.5mm from case 10 sec. max.)	260°C, max.

PHYSICAL SPECIFICATIONS	
Case Material	Copper
Base Material	Non-conductive Black Plastic(UL94V-0 rated)
Pin Material	$\Phi 1.0$ mm Brass Solder-coated
Potting Material	Epoxy (UL94V-0 rated)
Weight	19.0g
Dimensions	1.00"x1.00"x0.41"

ENVIRONMENTAL SPECIFICATIONS	
Operating Ambient Temperature	-40°C ~ +100°C(See Derating Curve) -40°C ~ +55°C(For 100% load)
Maximum Case Temperature	105°C
Thermal Impedance	Without Heat-sink 13°C/W, min. With Heat-sink 12°C/W, min.
Storage Temperature	-55°C ~ +125°C
Over Temperature Protection (Case)	115°C, typ.
Cooling(7)	Nature Convection

EMC CHARACTERISTICS		
Radiated Emissions	EN55032	CLASS A
Conducted Emissions(8)	EN55032	CLASS A
ESD	IEC61000-4-2	Perf. Criteria A
RS	IEC61000-4-3	Perf. Criteria A
EFT(9)	IEC61000-4-4	Perf. Criteria A
Surge (9)	IEC61000-4-5	Perf. Criteria A
CS	IEC61000-4-6	Perf. Criteria A
PFMF	IEC61000-4-8	Perf. Criteria A

SN - 30W 2:1 Regulated Single & Dual output

PART NUMBER STRUCTURE

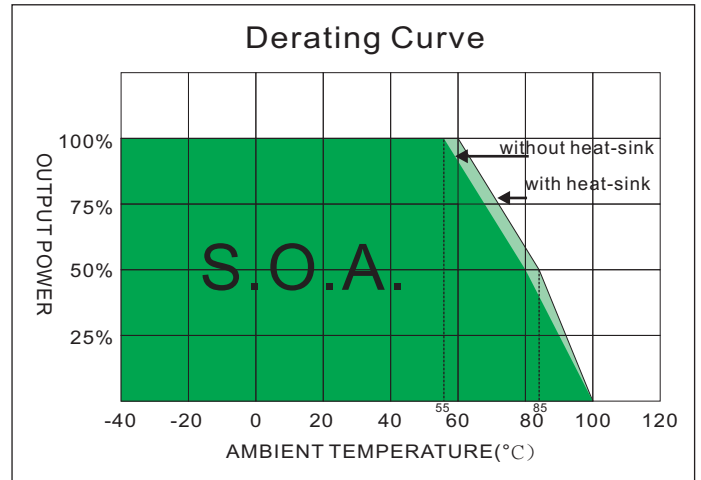
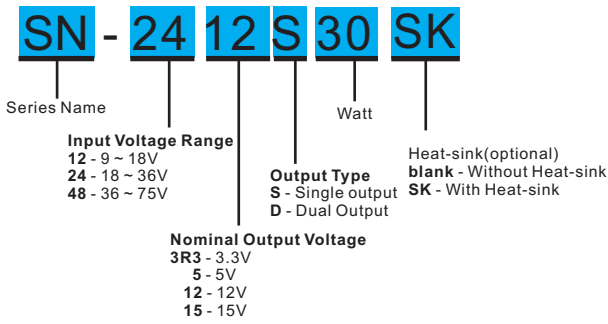

MODEL SELECTION GUIDE

MODEL NUMBER	INPUT Voltage Range (Vdc)	INPUT Current		OUTPUT Voltage (Vdc)	OUTPUT Current		EFFICIENCY @FL (% , typ.)	Capacitor Load @FL (µF, max.)
		No-Load (mA, max.)	Full Load (mA, typ.)		Min. load (mA)	Full load (mA)		
SN-123R3S30	9-18, 12V Nominal	10	2212.64	3.3	0	7000	87	10000
SN-1205S30	9-18, 12V Nominal	10	2808.99	5	0	6000	89	7200
SN-1212S30	9-18, 12V Nominal	12	2808.99	12	0	2500	89	1200
SN-1215S30	9-18, 12V Nominal	12	2777.78	15	0	2000	90	1000
SN-243R3S30	18-36, 24V Nominal	10	1106.32	3.3	0	7000	87	10000
SN-2405S30	18-36, 24V Nominal	10	1388.89	5	0	6000	90	7200
SN-2412S30	18-36, 24V Nominal	10	1388.89	12	0	2500	90	1200
SN-2415S30	18-36, 24V Nominal	10	1373.63	15	0	2000	91	1000
SN-483R3S30	36-75, 48V Nominal	8	540.73	3.3	0	7000	89	10000
SN-4805S30	36-75, 48V Nominal	8	686.81	5	0	6000	91	7200
SN-4812S30	36-75, 48V Nominal	8	686.81	12	0	2500	91	1200
SN-4815S30	36-75, 48V Nominal	8	679.35	15	0	2000	92	1000
SN-1212D30	9-18, 12V Nominal	12	2808.99	±12	0	±1250	89	±750
SN-1215D30	9-18, 12V Nominal	14	2777.78	±15	0	±1000	90	±500
SN-2412D30	18-36, 24V Nominal	10	1388.89	±12	0	±1250	90	±750
SN-2415D30	18-36, 24V Nominal	10	1373.63	±15	0	±1000	91	±500
SN-4812D30	36-75, 48V Nominal	8	686.81	±12	0	±1250	91	±750
SN-4815D30	36-75, 48V Nominal	8	679.35	±15	0	±1000	92	±500

NOTE

- One load is 25% to 100% load, the other load is 100% load, the output voltage variable rate is within ±5%.
- Tested by minimal Vin and constant resistive load.
- Tested by normal Vin and 25% load step change (75%-50%-25% of Io).
- Measured Input reflected ripple current with a simulated source inductance of 12µH and a source capacitor Cin(47µF, ESR<1.0Ω at 100KHz).
- The remote on/off control pin is referenced to -Vin(pin2).
- Exceeding the absolute ratings of the unit could cause damage.
It is not allowed for continuous operating.
- "Nature Convection" is usually about 30-65 LFM but is not equal to still air (0 LFM).
- Input filter components are used to help meet conducted emissions,
Which application refer to the EMI Filter of design & feature configuration.
- An external filter is required if the module has to meet IEC61000-4-4, IEC61000-4-5.
The SN-12XXXX30 recommended two aluminum electrolytic capacitor (Nippon chemi-con KY series, 330µF/100V), two aluminum electrolytic capacitor (Nippon chemi-con KY series, 470µF/100V) and two inductance of 1.0µH.
The SN-24XXXX30 recommended an aluminum electrolytic capacitor (Nippon chemi-con KY series, 330µF/100V) and a TVS (SMDJ58A, 58V, 3000Watt peak pulse power) to connect in parallel.
The SN-48XXXX30 recommended an aluminum electrolytic capacitor (Nippon chemi-con KY series, 330µF/100V) and a TVS (SMDJ120A, 120V, 3000Watt peak pulse power) to connect in parallel.
Which application refer to the EFT/Surge Filter of design & feature configuration.

TEST CONFIGURATIONS

Input Reflected Ripple Current Test Step

Input reflected ripple current is measured through a source inductor L_{in} (12uH) and a source capacitor C_{in} (47uF, ESR<1.0Ω at 100KHz) at nominal input and full load.

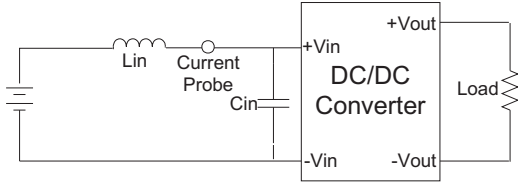

Output Ripple & Noise Measurement Test

To reduce ripple and noise, it is recommended to use a 10uF ceramic disk capacitor to at the output.

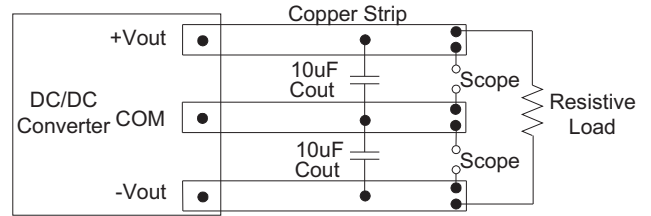

DESIGN & FEATURE CONFIGURATIONS

Over Voltage Protection

The module includes an internal output over voltage protection circuit, which monitors the voltage on the output terminals. If this voltage exceeds the over voltage set point, the module will activate the control loop of internal circuit to clamp the output voltage.

Over Temperature Protection

The over temperature protection consists of circuitry that provides protection from thermal damage. If the temperature exceeds the over temperature threshold the module will shut down.

The module will try to restart after shut down, If the over temperature condition still exists during restart, the module will shut down again. This restart trial will continue until the temperature is within specification.

EMI Filter

Input filter components (C1,L) are used to help meet conducted emissions . These components should be mounted as close as possible to the module; and all leads should be minimized to decrease radiated noise.

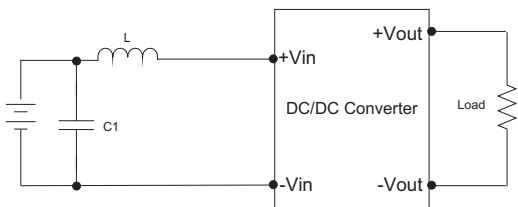

	C1	L
SN-12XXXXXX	1206,335K/50V,X7R	0.82uH
SN-24XXXXXX	none	
SN-48XXXXXX		

Over Current Protection

The module includes an internal over current protection circuit, which will endure current limiting for an unlimited duration during output over load condition. If the output current exceeds the OCP set point, the module will shut down automatically (hiccup).

The module will try to restart after shut down. If the over load condition still exists, the module will shut down again.

CTRL Module ON / OFF

Positive logic turns on the module during high logic and off during low logic.

Ctrl module on/off can be controlled by an external switch between the ctrl terminal and -Vin terminal. The switch can be an open collector or open drain

For positive logic if the ctrl feature is not used, please leave the ctrl pin floating.

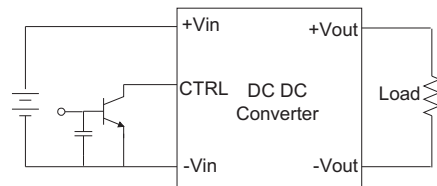

EFT/Surge Filter

Input filter components (C1,C2,C3,C4,L1,L2,D1) are used to help meet IEC61000-4-4 and IEC61000-4-5 .

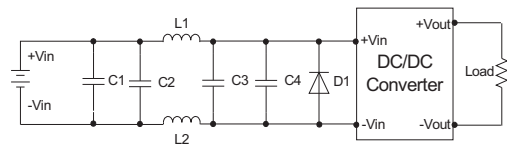

	C1	C2	L1 · L2	C3	C4	D1
SN-12XXXXXX	330uF,100V	470uF,100V	1uH	330uF,100V	470uF,100V	none
SN-24XXXXXX	330uF,100V	none	short	none	none	TVS,58V,3kW
SN-48XXXXXX	330uF,100V	none	short	none	none	TVS,120V,3kW

SN - 30W 2:1 Regulated Single & Dual output

MECHANICAL SPECIFICATIONS

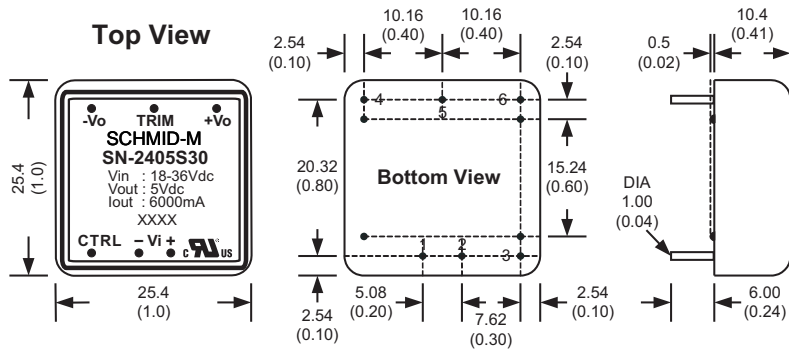

PIN CONNECTIONS		
PIN NUMBER	SINGLE	DUAL
1	+Vin	+Vin
2	-Vin	-Vin
3	CTRL	CTRL
4	+Vout	+Vout
5	Trim	Com
6	-Vout	-Vout

All dimensions are typical in millimeters (inches).

1. Pin diameter: 1.0 ± 0.05 (0.04 ± 0.002)
2. Pin pitch tolerance: ± 0.35 (± 0.014)
3. Case Tolerance: ± 0.5 (± 0.02)
4. Stand-off tolerance: ± 0.1 (± 0.004)

EXTERNAL OUTPUT TRIMMING

Output can be externally trimmed by using the method as below. (single output models only)

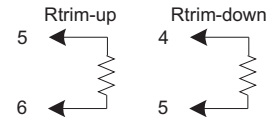

MECHANICAL SPECIFICATIONS

With Heat-sink

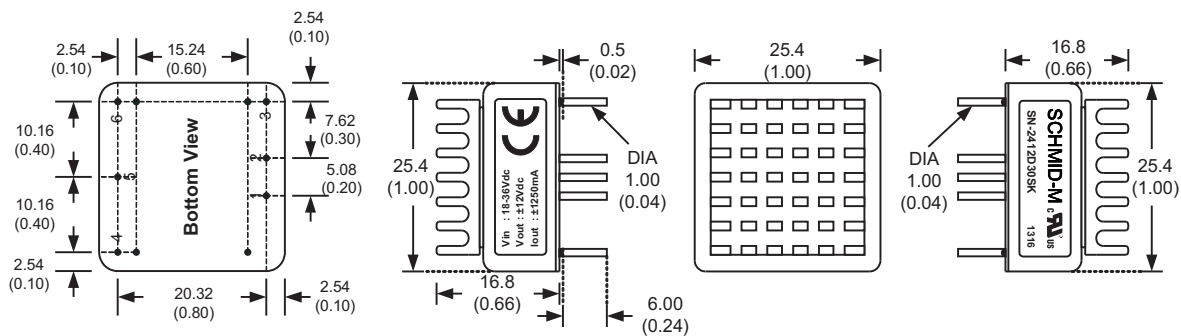

Order code: SN-XXXXX30SK(contain: heat-sink, thermal pad)
 Material: Aluminum
 Finish: Anodic treatment (black)
 Weight: 2.9 g (0.1oz) (without converter)

Note:

1. Converters will be supplied with heat-sinks already mounted.
Please contact factory for quotation.