

## DC/DC Converter

### SURA\_LD-20WR3 & SURB\_LD-20WR3 Series



# SCHMID-M

20W, Ultra wide input isolated & regulated dual / single output DC/DC converter

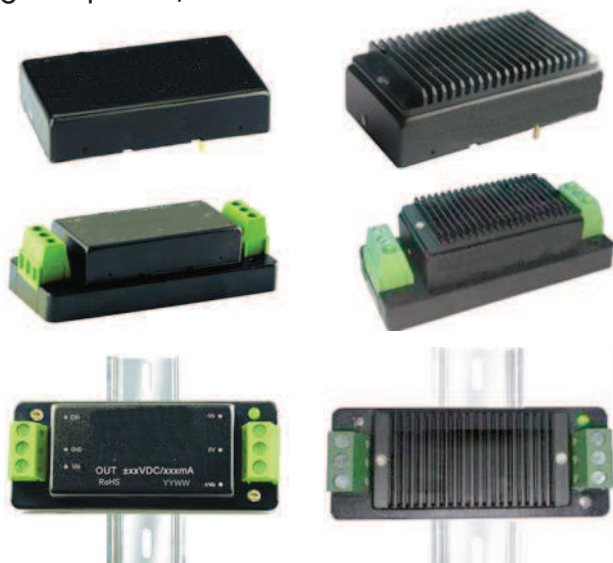

## FEATURES

- Wide range of input voltage (4:1)
- Efficiency up to 90%
- No-load power consumption as low as 0.2W
- Isolation voltage : 1500VDC
- Operating temperature range: -40°C to +85°C
- Input under-voltage protection, output short circuit protection, over-voltage protection, Over-current protection
- Meet CISPR22/EN55022 CLASS A
- Six-sided metal shielding package
- A2S (wiring mounting) and A4S (35mm rail mounting) products featuring reverse polarity protection for input

*SURA\_LD-20WR3 & SURB\_LD-20WR3 series are applied to wide voltage range input situation such as data transmission device, battery power supply device, tele-communication device, distributed power supply system, remote control system, industrial robot system etc.*

## Selection Guide

Part No. <sup>①</sup>	Input Voltage (VDC)		Output		Efficiency <sup>③</sup> (% Min./Typ.) @ Full Load	Max. Capacitive Load <sup>④</sup> (μF)
	Nominal (Range)	Max. <sup>②</sup>	Output Voltage (VDC)	Output Current (mA)(Max./Min.)		
SURA2405LD-20WR3	24 (9-36)	40	±5	±2000/±100	84/86	4800
SURA2409LD-20WR3			±9	±1111/±56	86/88	1000
SURA2412LD-20WR3			±12	±834/±42	86/88	800
SURA2415LD-20WR3			±15	±667/±33	86/88	625
SURB2403LD-20WR3			3.3	5000/250	84/86	10000
SURB2405LD-20WR3			5	4000/200	88/90	10000
SURB2409LD-20WR3			9	2222/111	87/89	4700
SURB2412LD-20WR3			12	1667/84	87/89	1600
SURB2415LD-20WR3			15	1333/67	88/90	1000
SURB2424LD-20WR3			24	834/42	88/90	500
SURA4805LD-20WR3	48 (18-75)	80	±5	±2000/±100	84/86	4800
SURA4812LD-20WR3			±12	±834/±42	86/88	800
SURA4815LD-20WR3			±15	±667/±33	87/89	625
SURB4803LD-20WR3			3.3	5000/250	84/86	10000
SURB4805LD-20WR3			5	4000/200	88/90	10000
SURB4809LD-20WR3			9	2222/111	87/89	4700
SURB4812LD-20WR3			12	1667/84	87/89	1600
SURB4815LD-20WR3			15	1333/67	88/90	1000
SURB4824LD-20WR3			24	834/42	88/90	500

Notes: <sup>①</sup>Series with suffix "H" are heat sink mounting; series with suffix "A2S" are chassis mounting, with suffix "A4S" are DIN-Rail mounting, for example SURB2405LD-20WR3A2S is chassis mounting of with heat sink, SURB2405LD-20WR3A4S is DIN-Rail mounting of without heat sink; If the application has a higher requirement for heat dissipation, you can choose modules with heat sink;

<sup>②</sup>Absolute maximum rating without damage on the converter, but it isn't recommended;

<sup>③</sup>Efficiency is measured in nominal input voltage and rated output load; A2S (wiring) and A4S (rail) Model due to input reverse polarity protection, minimum efficiency greater than Min.-2 is qualified;

<sup>④</sup>The capacitive loads of positive and negative outputs are identical.

# DC/DC Converter

## SURA\_LD-20WR3 & SURB\_LD-20WR3 Series

### Input Specifications

Item	Operating Conditions	Min.	Typ.	Max.	Unit	
Input Current (full load / no-load)	24VDC input	3.3V, 5V output	--	926/40	--	mA
		Others	--	926/5	--	
	48VDC input	3.3V, 5V output	--	463/20	--	
		Others	--	463/4	--	
Reflected Ripple Current	24VDC input	--	30	--		
	48VDC input	--	30	--		
Input Impulse Voltage (1sec. max.)	24VDC input	-0.7	--	50	VDC	
	48VDC input	-0.7	--	100		
Starting Voltage	24VDC input	--	--	9	VDC	
	48VDC input	--	--	18		
Under Voltage Shutdown	24VDC input	5.5	6.5	--		
	48VDC input	14.0	15.5	--		
Starting Time	Nominal input& constant resistance load	--	10	--	ms	
Input Filter		Pi filter				
Ctrl*	Module switch on	Ctrl suspended or connected to TTL high level (3.5-12VDC)				
	Module switch off	Ctrl pin connected to GND or low level (0-1.2VDC)				
	Input current when switched off	--	4	7	Ma	

Note: \*The voltage of Ctrl pin is relative to input pin GND.

### Output Specifications

Item	Operating Conditions	Min.	Typ.	Max.	Unit	
Positive Output Voltage Accuracy		--	±1	±3	%	
Negative Output Voltage Accuracy						
Balance of Output Voltage	Dual output, balanced load	--	±0.5	±1.5		
Line Regulation	Full load, the input voltage is from low voltage to high voltage	--	±0.2	±0.5		
Load Regulation	10%-100% load	--	±0.5	±1		
Cross Regulation	Dual output, main output 50% load, Supplement output from 10% to 100% load	--	--	±5		
Transient Recovery Time		--	300	500	µs	
Transient Response Deviation	25% load step change	3.3V, 5V, ±5V output	--	±5	±8	%
		Others	--	±3	±5	
Temperature Drift Coefficient	Full load	--	±0.02	--	%/°C	
Ripple & Noise	20MHz bandwidth	--	50	100	Mv p-p	
Trim	Input voltage range	--	±10	--	%Vo	
Output Over-voltage Protection		110	--	160		
Output Over-current Protection		110	--	190	%Io	
Output Short circuit Protection		Hiccup, Continuous, self-recovery				

Note: \* Ripple and noise tested with "parallel cable" method, please see *DC-DC Converter Application Notes* for specific operation methods.

### General Specifications

Item	Operating Conditions	Min.	Typ.	Max.	Unit
Insulation Voltage	Input-output, with the test time of 1 minute and the leak current lower than 1mA	1500	--	--	VDC
Insulation Resistance	Input-output, insulation voltage 500VDC	1000	--	--	MΩ
Isolation Capacitance	Input-output, 100KHz/0.1V	--	1050	--	pF
Operating Temperature	see Fig. 1	-40	--	85	°C
Storage Temperature		-55	--	125	
Storage Humidity	Non-condensing	5	--	95	%RH
Max. Operating Temperature for casing	Within the operating temperature curve	--	--	105	°C

# DC/DC Converter

## SURA\_LD-20WR3 & SURB\_LD-20WR3 Series

Pin Welding Resistance Temperature	Welding spot is 1.5mm away from the casing, 10 seconds	--	--	300	°C
Vibration		10-55Hz, 10G, 30 Min. along X, Y and Z			
Switching Frequency *	PWM mode	--	270	--	KHz
MTBF	MIL-HDBK-217F@25°C	1000	--	--	K hours

Note:\* This series of products using reduced frequency technology, the switching frequency is test value of full load, When the load is reduced to below 50%, the switching frequency decreases with decreasing load.

### Physical Specifications

Casing Material	Aluminum alloy				
Package Dimensions	Horizontal package( without heat sink)		50.80*25.40*11.80 mm		
	Horizontal package( with heat sink)		50.80*25.40*16.30 mm		
	A2S wiring package ( without heat sink)		76.00*31.50*21.20 mm		
	A2S wiring package( with heat sink)		76.00*31.50*25.10 mm		
	A4S rail package( without heat sink)		76.00*31.50*25.80 mm		
	A4S rail package( with heat sink)		76.00*31.50*29.70 mm		
Weight	without heat sink	Horizontal package/A2S wiring package/A4S rail package	26.00g/48.00g/68.00g(Typ.)		
	with heat sink	Horizontal package/A2S wiring package/A4S rail package	34.00g/56.00g/76.00g(Typ.)		
Cooling Method	Free air convection				

### EMC Specifications

EMI	Conducted disturbance	CISPR22/EN55022 CLASS A (Bare component)/ CLASS B (see Fig.3-② for recommended circuit)			
	Radiated emission	CISPR22/EN55022 CLASS A (Bare component)/ CLASS B (see Fig.3-② for recommended circuit)			
EMS	Electrostatic discharge	IEC/EN61000-4-2	Contact ±4KV	perf. Criteria B	
	Radiation Immunity	IEC/EN61000-4-3	10V/m	perf. Criteria A	
	EFT	IEC/EN61000-4-4	±2KV (see Fig.3-① for recommended circuit)	perf. Criteria B	
	Surge immunity	IEC/EN61000-4-5	±2KV (see Fig.3-① for recommended circuit)	perf. Criteria B	
	Conducted disturbance immunity	IEC/EN61000-4-6	3 Vr.m.s	perf. Criteria A	
	Immunities of voltage dip, drop and short interruption	IEC/EN61000-4-29	0-70%	perf. Criteria B	

### Product Characteristic Curve

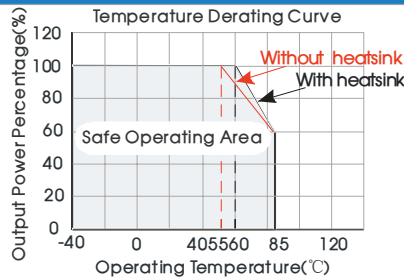
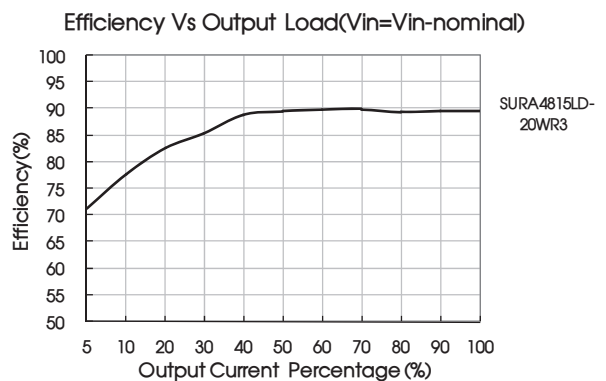
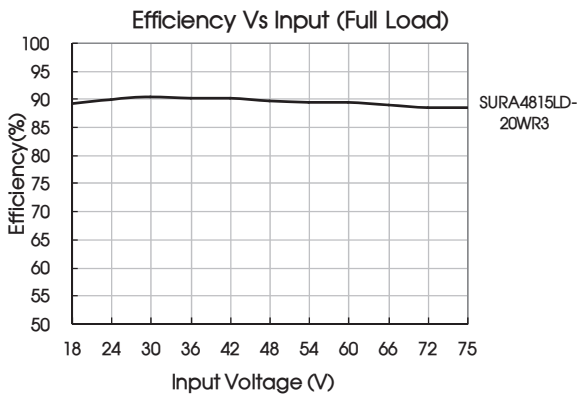
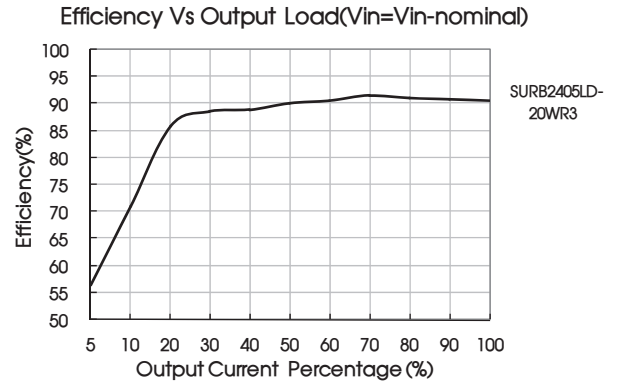
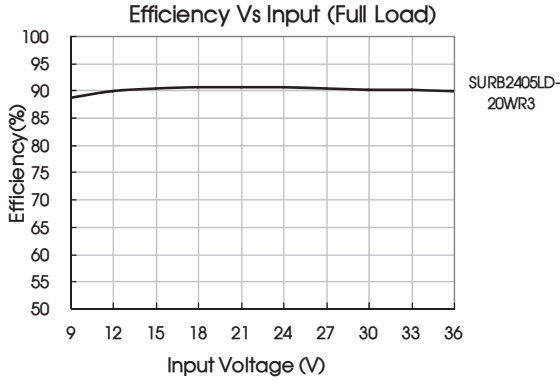

Fig. 1



# DC/DC Converter

## SURA\_LD-20WR3 & SURB\_LD-20WR3 Series



### Design Reference

#### 1. Typical application

All the DC/DC converters of this series are tested according to the recommended circuit (see Fig. 2) before delivery. If it is required to further reduce input and output ripple, properly increase the input & output of additional capacitors  $C_{in}$  and  $C_{out}$  or select capacitors of low equivalent impedance provided that the capacitance is no larger than the max. capacitive load of the product.

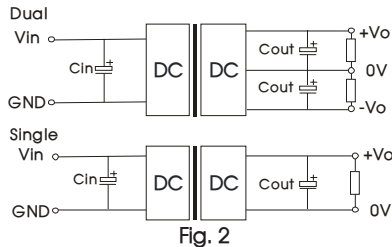

Single Vout (VDC)	Cout ( $\mu$ F)	Cin ( $\mu$ F)	Dual Vout (VDC)	Cout ( $\mu$ F)	Cin ( $\mu$ F)
3.3/5	470	100	$\pm 5$	220	100
9/12/15	220		$\pm 9/\pm 12/\pm 15$	100	
24	100		--	--	

#### 2. EMC solution-recommended circuit

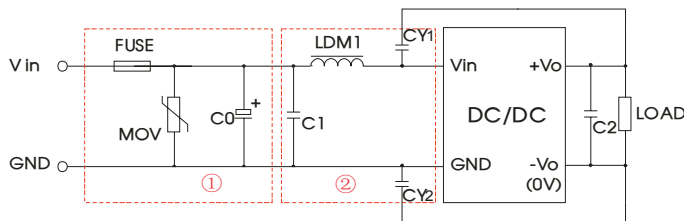

Fig. 3

Notes: Part ① in the Fig. 3 is used for EMS test and part ② for EMI filtering; selected based on needs.

#### Parameter description

Model	Vin:24V	Vin:48V
FUSE	Choose according to actual input current	
MOV	S14K35	S14K30
C0	330 $\mu$ F/50V	330 $\mu$ F/100V
C1	1 $\mu$ F/50V	1 $\mu$ F/100V
C2	Refer to the Cout in Fig.2	
LDM1	4.7 $\mu$ H	
CY1, CY2	1nF/2KV	

#### EMC solution-recommended circuit PCB layout

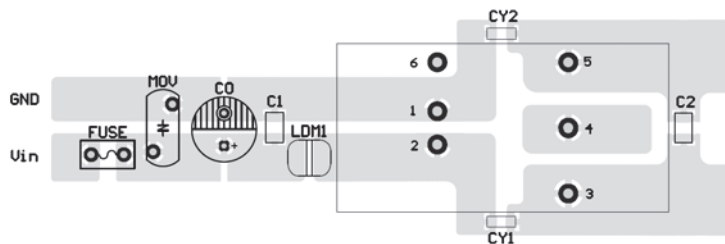

Fig. 4

Note: the min. distance of the bonding pads between input & output isolation capacitors (CY1/CY2) shall be  $\geq 2$ mm.

# DC/DC Converter

## SURA\_LD-20WR3 & SURB\_LD-20WR3 Series

### 3. Application of Trim and calculation of Trim resistance

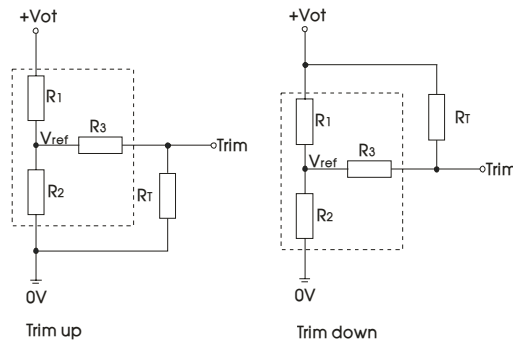

Applied circuits of Trim (Part in broken line is the interior of models)

Calculation formula of Trim resistance:

$$\begin{aligned} \text{up: } R_T &= \frac{\alpha R_2}{R_2 - \alpha} \cdot R_3 & \alpha &= \frac{V_{ref}}{V_o' - V_{ref}} \cdot R_1 \\ \text{down: } R_T &= \frac{\alpha R_1}{R_1 - \alpha} \cdot R_3 & \alpha &= \frac{V_o' - V_{ref}}{V_{ref}} \cdot R_2 \end{aligned}$$

$R_T$  is Trim resistance  
 $\alpha$  is a self-defined parameter, with no real meaning.

Vout(V)	R1(KΩ)	R2(KΩ)	R3(KΩ)	Vref(V)
3.3	4.801	2.87	12.4	1.25
5	2.883	2.87	10	2.5
9	7.500	2.87	15	2.5
12	11.000	2.87	15	2.5
15	14.494	2.87	15	2.5
24	24.872	2.87	17.8	2.5

### 4. The product does not support output in parallel with power per liter or hot-plug use

## Horizontal Package (without heat sink) Dimensions and Recommended Layout

Note:  
 Unit :mm[inch]  
 Pin diameter tolerances :±0.10[±0.004]  
 Pin height tolerances :±0.50[±0.020]  
 General tolerances:±0.30[±0.012]

THIRD ANGLE PROJECTION

Note : Grid 2.54\*2.54mm

Pin-Out		
Pin	Single	Dual
1	GND	GND
2	Vin	Vin
3	+Vo	+Vo
4	Trim	0V
5	0V	-Vo
6	Ctrl	Ctrl

# DC/DC Converter

SURA\_LD-20WR3 & SURB\_LD-20WR3 Series

## Horizontal Package (with heat sink) Dimensions

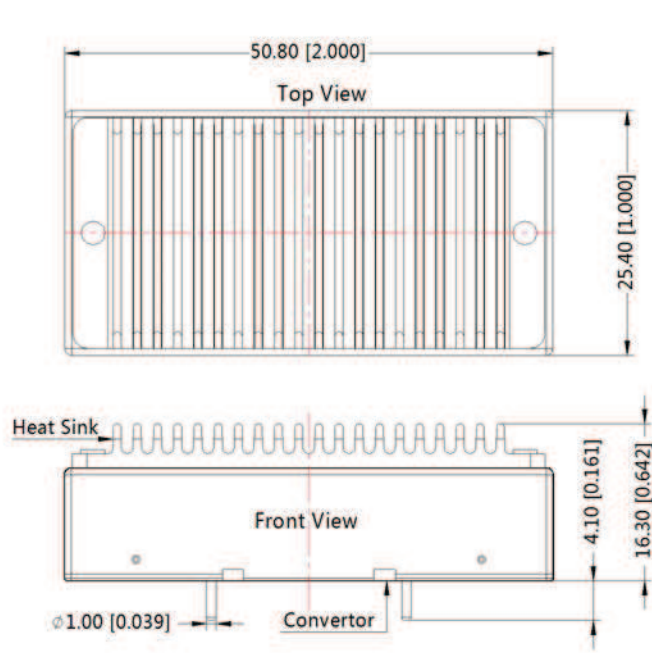

THIRD ANGLE PROJECTION

Pin-Out		
Pin	Single	Dual
1	GND	GND
2	Vin	Vin
3	+Vo	+Vo
4	Trim	0V
5	0V	-Vo
6	Ctrl	Ctrl

Note:  
 Unit :mm[inch]  
 General tolerances:±0.50[±0.020]  
 If use heatsinks,make sure there is enough space for a special size in ther above graph

## SURA\_LD-20WR3A2S & SURB\_LD-20WR3A2S(without heat sink) Dimensions

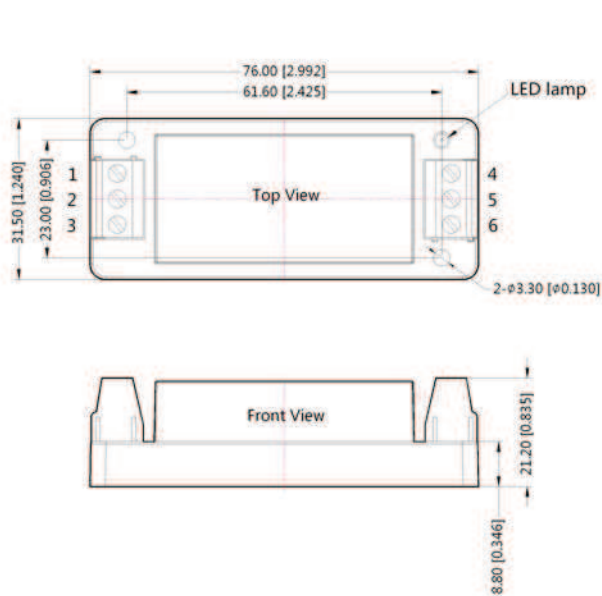

THIRD ANGLE PROJECTION

Pin-Out						
Pin	1	2	3	4	5	6
Dual	Ctrl	GND	Vin	-Vo	0V	+Vo
Single	Ctrl	GND	Vin	0V	Trim	+Vo

Note:  
 Unit:mm[inch]  
 Wire range : 24~12 AWG  
 General tolerances:±0.50[±0.020]

# DC/DC Converter

## SURA\_LD-20WR3 & SURB\_LD-20WR3 Series

### SURA\_LD-20WHR3A2S & SURB\_LD-20WHR3A2S(with heat sink) Dimensions

THIRD ANGLE PROJECTION

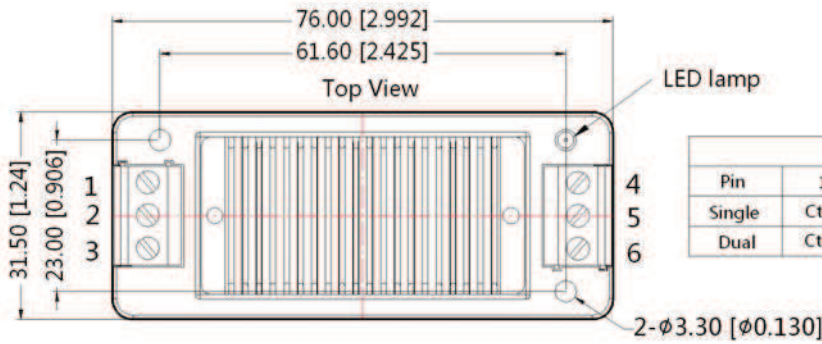

Pin-Out						
Pin	1	2	3	4	5	6
Single	Ctrl	GND	Vin	0V	Trim	+Vo
Dual	Ctrl	GND	Vin	-Vo	0V	+Vo

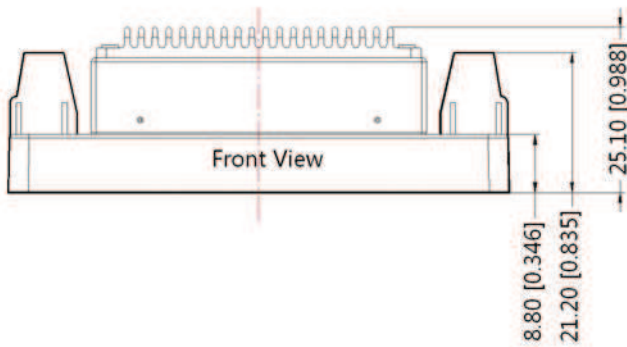

Note:  
Unit:mm[inch]  
Wire range:24~12 AWG  
General tolerances:±0.50[±0.020]

### SURA\_LD-20WR3A4S & SURB\_LD-20WR3A4S(without heat sink) Dimensions

THIRD ANGLE PROJECTION

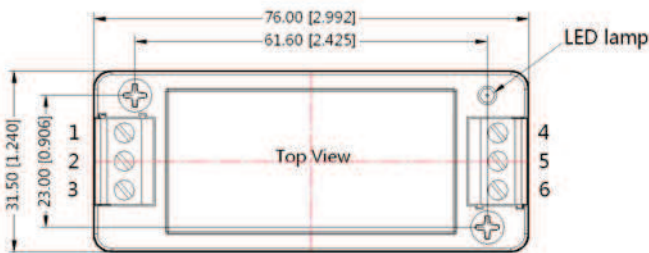

Pin-Out						
Pin	1	2	3	4	5	6
Dual	Ctrl	GND	Vin	-Vo	0V	+Vo
Single	Ctrl	GND	Vin	0V	Trim	+Vo

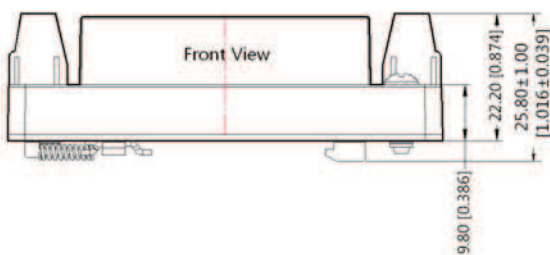

Note:  
Unit:mm[inch]  
Wire range : 24~12 AWG  
General tolerances:±0.50[±0.020]

# DC/DC Converter

## SURA\_LD-20WR3 & SURB\_LD-20WR3 Series

### SURA\_LD-20WHR3A4S & SURB\_LD-20WHR3A4S(with heat sink) Dimensions

THIRD ANGLE PROJECTION 

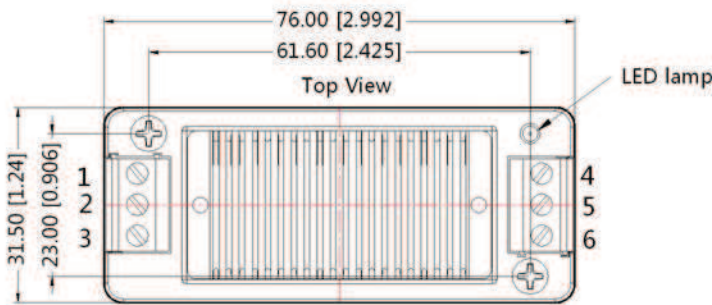

Pin-Out						
Pin	1	2	3	4	5	6
Single	Ctrl	GND	Vin	0V	Trim	+Vo
Dual	Ctrl	GND	Vin	-Vo	0V	+Vo

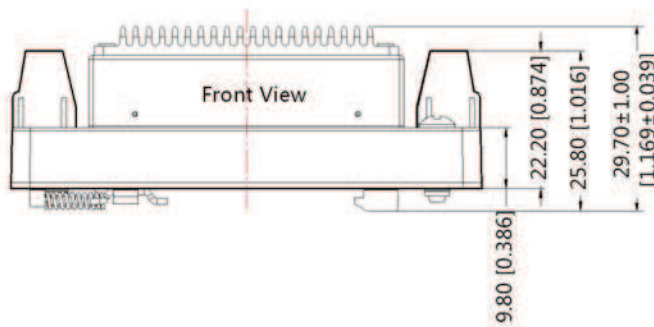

Note:  
 Unit:mm[inch]  
 Wire range:24~12 AWG  
 General tolerances:±0.50[±0.020]

**Notes:**

1. Packing Information please refer to 'Product Packing Information'. The Packing bag number of Horizontal package :58200024(without heat sink), 58200043(with heat sink, the Packing bag number of A2S/ A4S package:58220022;
2. Recommended used in more than 5% load, if the load is lower than 5%, then the ripple index of the product may exceed the specification, but does not affect the reliability of the product;
3. The unbalance degree of the recommended dual output module load: ≤ 5%; if the degree exceeds ±5%, then the product performances cannot be guaranteed to comply with all the performance indicators in the manual, and please directly contact our technicians for specific information;
4. The max. capacitive load should be tested within the input voltage range and under full load conditions;
5. Unless otherwise specified, data in this datasheet should be tested under the conditions of Ta=25°C, humidity<75% when inputting nominal voltage and outputting rated load;
6. All index testing methods in this datasheet are based on our Company's corporate standards;
7. The performance indexes of the product models listed in this datasheet are as above, but some indexes of non-standard model products will exceed the above-mentioned requirements, and please directly contact our technicians for specific information;
8. We can provide product customization service;
9. Specifications of this product are subject to changes without prior notice.