

SU Series

12W 2:1 Regulated Single & Dual output

SCHMID-M



Features

- Wide 2:1 Input Range
- Full SMD Technology
- 1600 VDC Isolation
- Efficiency up to 91%
- -40 ~ 85 °C Operation Temperature Range
- Continuous Short Circuit Protection
- No Minimum Load Required
- Over Voltage Protection
- Low no load Input Current
- Soft Start
- High Power Density: 12W in DIL-24 Package
- Remote On/Off



The SU series are cost effective 12W single & dual output DC-DC converters. These converters are consisted with nickle-coated copper 24-pin DIL package with high performance features such as synchronous rectification, high efficiency and tight line / load regulation. Devices are encapsulated using flame retardant resin. Input voltages of 12, 24 and 48 with output voltage of 2.5, 3.3, 5, 12, 15, ± 12 , ± 15 Vdc. Features include high efficiency operation up to 91%.

ALL SPECIFICATIONS ARE TYPICAL AT 25°C, NOMINAL INPUT AND FULL LOAD UNLESS OTHERWISE NOTED.

OUTPUT SPECIFICATIONS	
Output Voltage Accuracy	$\pm 1.2\%$
Maximum Output Current	See table
Line Regulation	$\pm 0.5\%$, max.
Load Regulation (0% Load to Full Load) Single	$\pm 0.5\%$, max.
Load Regulation (0% Load to Full Load) Dual	$\pm 1.0\%$, max.
Cross Regulation (Dual Output) (1)	$\pm 5\%$
Ripple & Noise (2)	85mVpk-pk, max.
	2.5V, 3.3V output 3.9V
	5V output 6.2V
Over Voltage Protection	12V output 15V
(Zener diode clamp)	15V output 18V
	± 12 V output ± 15 V
	± 15 V output ± 18 V
Over Current Protection	150% of FL, typ.
Short Circuit Protection	Indefinite (hiccup) (Automatic Recovery)
Temperature Coefficient	$\pm 0.02\%/^{\circ}\text{C}$
Capacitive Load (3)	See table
Transient Recovery Time (4)	250us, typ.
Transient Response Deviation (4)	$\pm 3\%$, max.

INPUT SPECIFICATIONS	
Input Voltage Range	See table
Start up Time	20mS, typ.
(Nominal Vin and constant resistive load)	
Input Filter	Pi Type
Input Current (No-Load)	See table, max.
Input Current (Full-Load)	See table, typ.
Input Reflected Ripple Current	20mApk-pk
Remote On/Off (CTRL)	
	ON: 3.0 ... 12Vdc or open circuit
	OFF: 0 ... 1.2Vdc or Short circuit pin1 and pin 2/3
	OFF idle current: 5.0 mA typ.

ENVIRONMENTAL SPECIFICATIONS	
Operating Ambient Temperature	-40°C ~ +85°C (See Derating Curve) -40°C ~ +60°C (For 100% load)
Maximum Case Temperature	100°C
Storage Temperature	-55°C ~ +125°C
Cooling	Nature Convection

GENERAL SPECIFICATIONS	
Efficiency	See table, typ.
I/O Isolation Voltage (60 sec)	
Input/Output	1600Vdc
Case/Input & Output	1600Vdc
Isolation Resistance	1000 M Ω , min.
Isolation Capacitance	1200 pF, max.
Switching frequency	330kHz, typ.
Humidity	95% rel H
Reliability Calculated MTBF (MIL-HDBK-217 F)	>1 Mhrs
Safety Standard : (designed to meet)	IEC 60950-1

EMC CHARACTERISTICS		
Radiated Emissions	EN55022	CLASS A
Conducted Emissions (5)	EN55022	CLASS A
ESD	IEC61000-4-2	Perf. Criteria B
RS	IEC61000-4-3	Perf. Criteria A
EFT	IEC61000-4-4	Perf. Criteria A
Surge (6)	IEC61000-4-5	Perf. Criteria A
CS	IEC61000-4-6	Perf. Criteria A
PFMF	IEC61000-4-8	Perf. Criteria A

PHYSICAL SPECIFICATIONS	
Case Material	Nickel-coated Copper
Base Material	Non-conductive black plastic (UL94V-0 rated)
Pin Material	$\Phi 0.5$ mm Brass Solder-coated
Potting Material	Epoxy (UL94V-0 rated)
Weight	18.0g
Dimensions	1.25"x0.8"x0.40"

ABSOLUTE SPECIFICATIONS (7)		
These are stress ratings. Exposure of devices to any of these conditions may adversely affect long-term reliability.		
Input Surge Voltage (1000mS)	12 Models	36Vdc, max.
	24 Models	50Vdc, max.
	48 Models	100Vdc, max.
Soldering Temperature		260°C, max.
(1.5mm from case 10 sec. max.)		

SU - 12W 2:1 Regulated Single & Dualoutput

PART NUMBER STRUCTURE

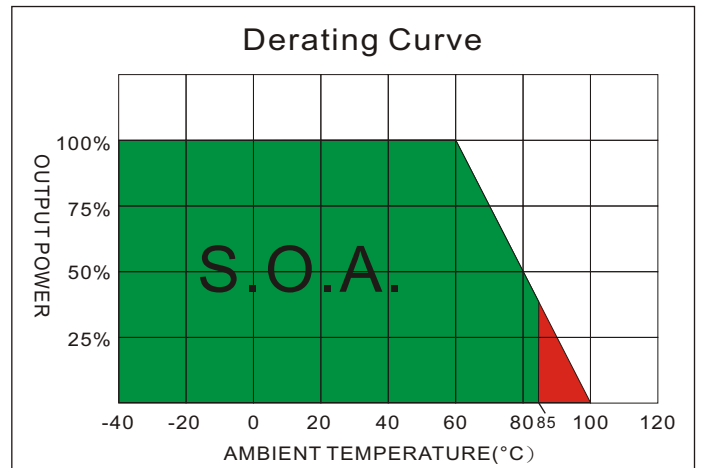
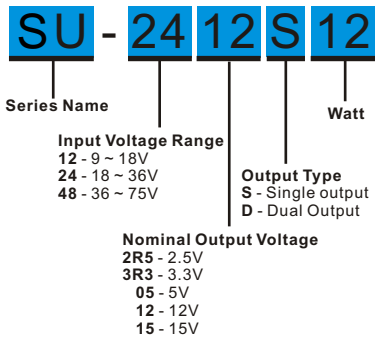

MODEL SELECTION GUIDE

MODEL NUMBER	INPUT Voltage Range (Vdc)	INPUT Current		OUTPUT Voltage (Vdc)	OUTPUT Current		EFFICIENCY @FL(%)	Capacitor Load(uF)
		No-Load (mA)	Full Load (mA)		Min. load (mA)	Full load (mA)		
SU-12 2R5S12	9-18	15	889	2.5	0	3500	85	2000
SU-12 3R3S12	9-18	15	1146	3.3	0	3500	87	2000
SU-12 05S12	9-18	15	1163	5	0	2400	89	2000
SU-12 12S12	9-18	15	1149	12	0	1000	90	430
SU-12 15S12	9-18	15	1149	15	0	800	90	300
SU-12 12D12	9-18	15	1149	±12	0	±500	90	±200
SU-12 15D12	9-18	15	1136	±15	0	±400	91	±120
SU-24 2R5S12	18-36	15	445	2.5	0	3500	85	2000
SU-24 3R3S12	18-36	15	573	3.3	0	3500	87	2000
SU-24 05S12	18-36	15	581	5	0	2400	89	2000
SU-24 12S12	18-36	15	575	12	0	1000	90	430
SU-24 15S12	18-36	15	575	15	0	800	90	300
SU-24 12D12	18-36	15	575	±12	0	±500	90	±200
SU-24 15D12	18-36	15	562	±15	0	±400	91	±120
SU-48 2R5S12	36-75	15	225	2.5	0	3500	84	2000
SU-48 3R3S12	36-75	15	283	3.3	0	3500	88	2000
SU-48 05S12	36-75	15	291	5	0	2400	89	2000
SU-48 12S12	36-75	15	294	12	0	1000	88	430
SU-48 15S12	36-75	15	291	15	0	800	89	300
SU-48 12D12	36-75	15	294	±12	0	±500	88	±200
SU-48 15D12	36-75	15	291	±15	0	±400	89	±120

NOTE

1. One load is 25% to 100% load, the other load is 100% load, the output voltage variable rate is within ±5%.
2. Maximum value at nominal input voltage, Measured with 20MHz bandwidth and 1.0uF ceramic capacitor.
3. Tested by minimal Vin and constant resistive load.
4. Tested by normal Vin and 25% load step change (75%-50%-25% of Io).
5. Input filter components (C1, L) are used to help meet conducted emissions requirement for the module. These components should be mounted as close as possible to the module; and all leads should be minimized to decrease radiated noise.
6. An external filter capacitor is required if the module has to meet IEC61000-4-5. The filter capacitor SCHMID-M suggest: Nipon chmi - con KY series, 330µF/100V.
7. Exceeding the absolute ratings of the unit could cause damage. It is not allowed for continuous operating.

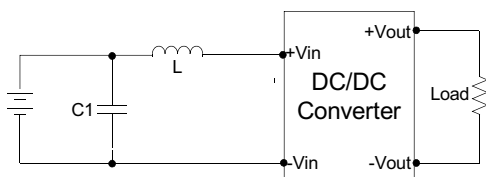

	C1	L
SU-12XXXXX	100uF, 100V	12uH
SU-24XXXXX	100uF, 100V	12uH
SU-48XXXXX	100uF, 100V	12uH

TEST CONFIGURATIONS

Input Reflected Ripple Current Test Step

Input reflected ripple current is measured through a source inductor L_{in} (12 μ H) and a source capacitor C_{in} (47 μ F, ESR<1.0 Ω at 100KHz) at nominal input and full load.

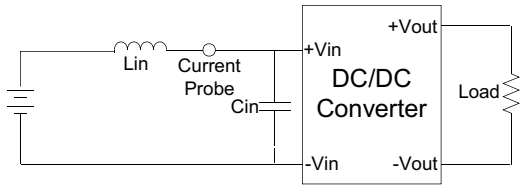

Output Ripple & Noise Measurement Test

Use a capacitor C_{out} (1.0 μ F) measurement. The Scope measurement bandwidth is 0-20MHz.

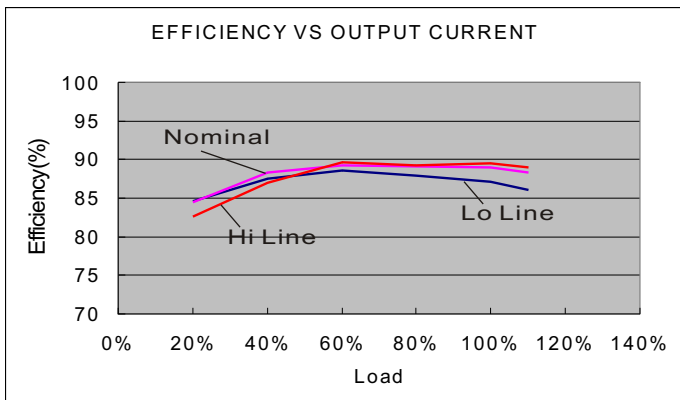
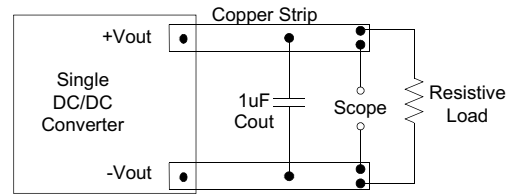

SU-1205S12

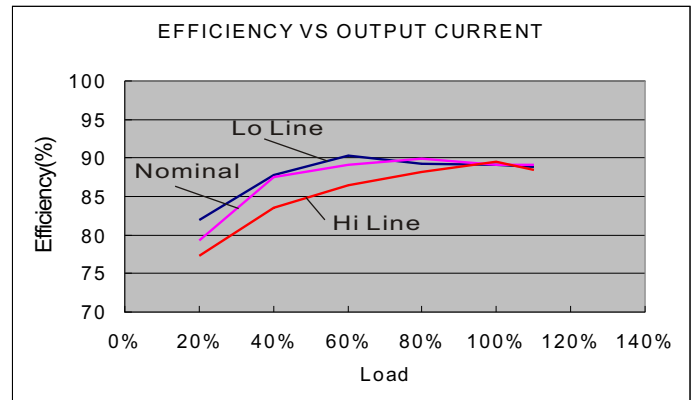

SU-2405S12

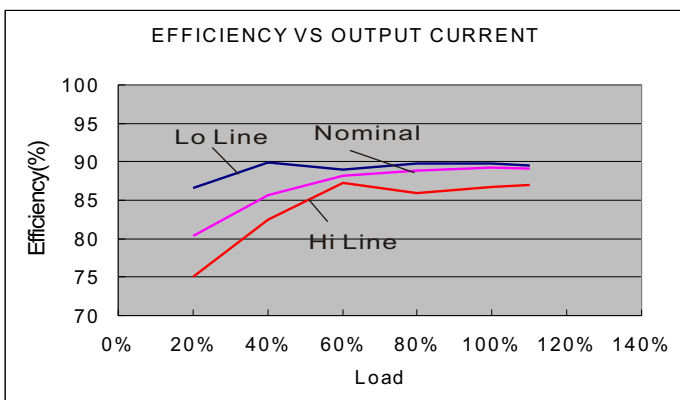

SU-4815S12

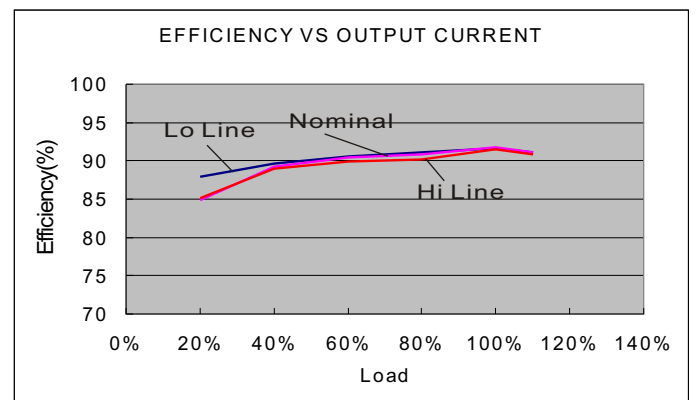

SU-2415D12

SU - 12W 2:1 Regulated Single & Dualoutput

MECHANICAL SPECIFICATIONS

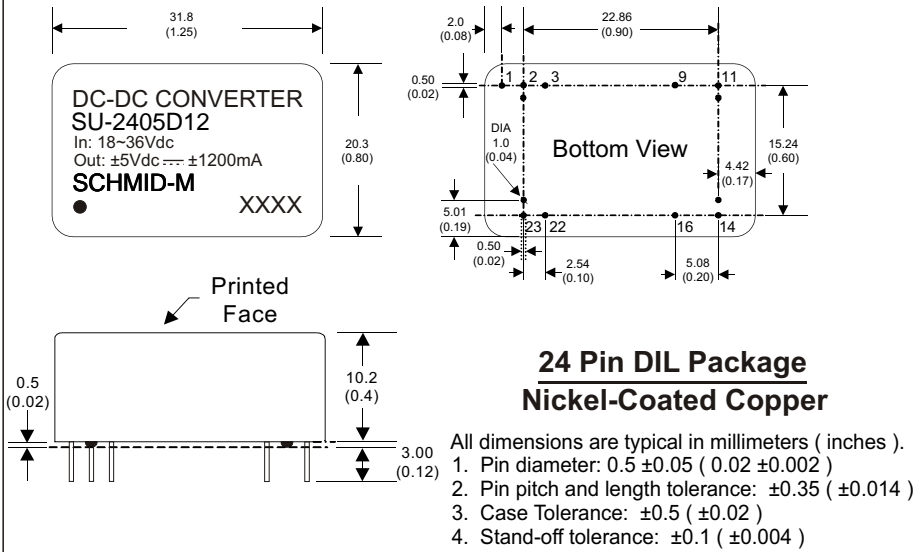

PIN CONNECTIONS

PIN NUMBER	SINGLE	DUAL
1	Remote On/Off	Remote On/Off
2	-V Input	-V Input
3	-V Input	-V Input
9	N.P.	Common
11	N.C.	-V Output
14	+V Output	+V Output
16	-V Output	Common
22	+V Input	+V Input
23	+V Input	+V Input