

DC/DC Converter

SURA_ZP-6WR3 & SURB_ZP-6WR3 Series



SCHMID-M

6W, Ultra wide input, isolated & regulated dual/single output, DIP package, DC-DC converter

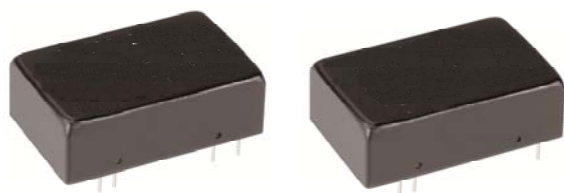

FEATURES

- Wide range of input voltage (4:1)
- Efficiency up to 88%
- No-load power consumption as low as 0.12W
- Isolation voltage : 1500VDC
- Operating temperature range: -40°C to +85°C
- Input under-voltage protection, short circuit , over-voltage & Over-current protection output
- Meet CISPR22/EN55022 CLASS A
- International standard pin-out
- Meet UL60950 , EN60950 and IEC60950

SURA_ZP-6WR & SURB_ZP-6WR3 series products are of 6W output power, extremely wide range of voltage input of 9-36VDC, 18-75VDC, isolation voltage of 1500VDC, output over-voltage protection and output short circuit protection with the bare component in compliance with CISPR22/EN55022 CLASS A; these products are widely used in fields such as industrial control, electric power, instruments and communication.

Selection Guide

Certification	Part No.	Input Voltage (VDC)		Output		Efficiency ^② (%Min./Typ.) @ Full Load	Max. Capacitive Load ^③ (μF)
		Nominal (Range)	Max. ^①	Output Voltage (VDC)	Output Current (mA) (Max./Min.)		
UL/CE/CB	SURA2405ZP-6WR3	24 (9-36)	40	±5	±600/±30	81/83	680
	SURA2412ZP-6WR3			±12	±250/±12	85/87	330
	SURA2415ZP-6WR3			±15	±200/±10	86/88	220
	SURA2424ZP-6WR3			±24	±125/±6	85/87	100
	SURB2403ZP-6WR3			3.3	1500/75	77/79	1800
	SURB2405ZP-6WR3			5	1200/60	81/83	1000
	SURB2409ZP-6WR3			9	667/33	82/84	1000
	SURB2412ZP-6WR3			12	500/25	85/87	470
	SURB2415ZP-6WR3			15	400/20	86/88	220
	SURB2424ZP-6WR3			24	250/13	85/87	100
	SURA4805ZP-6WR3	48 (18-75)	80	±5	±600/±30	81/83	680
	SURA4812ZP-6WR3			±12	±250/±12	85/87	330
	SURA4815ZP-6WR3			±15	±200/±10	86/88	220
	SURB4803ZP-6WR3			3.3	1500/75	78/80	1800
	SURB4805ZP-6WR3			5	1200/60	82/84	1000
	SURB4812ZP-6WR3			12	500/25	85/87	470
	SURB4815ZP-6WR3			15	400/20	86/88	220
	SURB4824ZP-6WR3			24	250/13	85/87	100

Notes:

- ① Absolute maximum rating without damage on the converter, but it isn't recommended;
- ② Efficiency is measured in nominal input voltage and rated output load;
- ③ The capacitive loads of positive and negative outputs are identical.

Input Specifications

Item	Operating Conditions	Min.	Typ.	Max.	Unit
Input Current (full load / no-load)	24VDC input	--	301/5	309/12	mA
	48VDC input	--	148/4	154/8	
Reflected Ripple Current		--	20	--	
Input impulse Voltage (1sec. max.)	24VDC input	-0.7	--	50	VDC
	48VDC input	-0.7	--	100	
Starting Voltage	24VDC input	--	--	9	VDC
	48VDC input	--	--	18	

DC/DC Converter

SURA_ZP-6WR3 & SURB_ZP-6WR3 Series

under-voltage turn-off	24VDC input	5.5	6.5	--	VDC
	48VDC input	14.0	15.5	--	
Input Filter	Pi filter				
Hot Plug	Unavailable				

Output Specifications

Item	Operating Conditions	Min.	Typ.	Max.	Unit	
Output Voltage Accuracy	Positive output	--	±1	±3	%	
	Negative output					
Balance of Output Voltage	Dual output, balanced load	--	±0.5	±1.5		
Line Regulation	Full load, the input voltage is from low voltage to high voltage	Positive output	±0.2	±0.5		
		Negative output	±0.5	±1		
Load Regulation	5%-100% load	Positive output	±0.5	±1		
		Negative output	±0.5	±1.5		
Cross Regulation	Dual output, main circuit with 50% load, auxiliary circuit with 10%-100% load	--	--	±0.5		
Transient Recovery Time	25% load step change	--	300	500		μs
Transient Response Deviation		3.3V, 5V, ±5V output	--	±5		±8
		Others	--	±3	±5	
Temperature Drift Coefficient	Full load	--	--	±0.03	%/°C	
Ripple*&Noise*	20MHz bandwidth	--	--	85	mV p-p	
Over-voltage Protection	Input voltage range	110	--	160	%Vo	
Over-current Protection		110	140	190	%Io	
Short circuit Protection		Continuous, self-recovery				

Note: * Ripple and noise tested with "parallel cable" method, please see *DC-DC Converter Application Notes* for specific operation methods.

General Specifications

Item	Operating Conditions	Min.	Typ.	Max.	Unit
Insulation Voltage	Input-output, with the test time of 1 minute and the leak current lower than 1mA	1500	--	--	VDC
Insulation Resistance	Input-output, insulation voltage 500VDC	1000	--	--	MΩ
Isolation Capacitance	Input-output, 100KHz/0.1V	--	1000	--	pF
Operating Temperature	Derating if the temperature is ≥71°C (see Fig. 1)	-40	--	85	°C
Storage Temperature		-55	--	125	
Storage Humidity	Non-condensing	5	--	95	%RH
Pin Welding Resistance Temperature	Welding spot is 1.5mm away from the casing, 10 seconds	--	--	300	
Vibration		10-55Hz, 10G, 30 Min. along X, Y and Z			
Switching Frequency *	PWM mode	--	300	--	KHz
MTBF	MIL-HDBK-217F@25°C	1000	--	--	K hours

Note: * This series of products using reduced frequency technology, the switching frequency is test value of full load, When the load is reduced to below 50%, the switching frequency decreases with decreasing load.

Physical Specifications

Casing Material	Aluminum alloy
Package Dimensions	32.00*20.00*10.80mm
Weight	14g(Typ.)
Cooling Method	Free air convection

DC/DC Converter

SURA_ZP-6WR3 & SURB_ZP-6WR3 Series

EMC Specifications

EMI	CE	CISPR22/EN55022 CLASS A (Bare component)/ CLASS B (see Fig.3-② for recommended circuit)	
	RE	CISPR22/EN55022 CLASS A (Bare component)/ CLASS B (see Fig.3-② for recommended circuit)	
EMS	ESD	IEC/EN61000-4-2	Contact $\pm 4\text{kV}$ perf. Criteria B
	RS	IEC/EN61000-4-3	10V/m perf. Criteria A
	EFT	IEC/EN61000-4-4	$\pm 2\text{kV}$ (see Fig.3-① for recommended circuit) perf. Criteria B
	Surge	IEC/EN61000-4-5	$\pm 2\text{kV}$ (see Fig.3-① for recommended circuit) perf. Criteria B
	CS	IEC/EN61000-4-6	3 V.r.m.s perf. Criteria A
	Immunities of voltage dip, drop and short interruption	IEC/EN61000-4-29	0-70% perf. Criteria B

Product Characteristic Curve

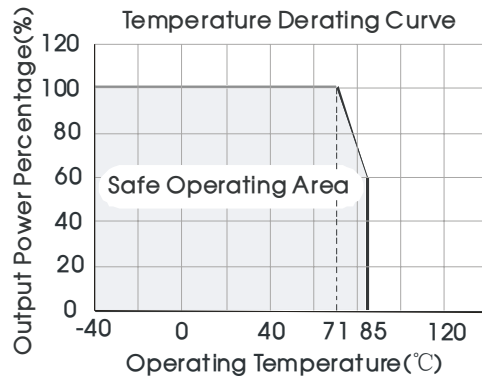
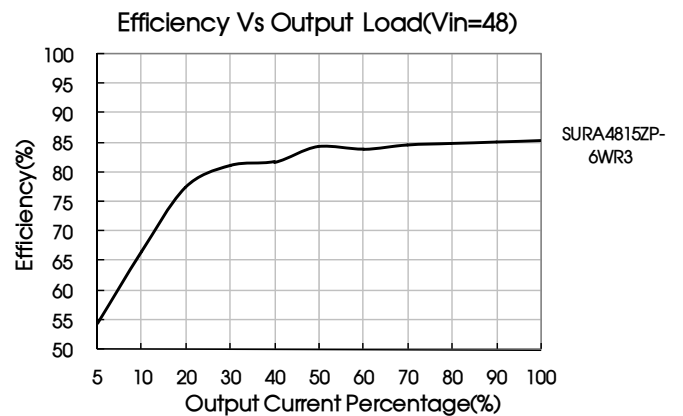
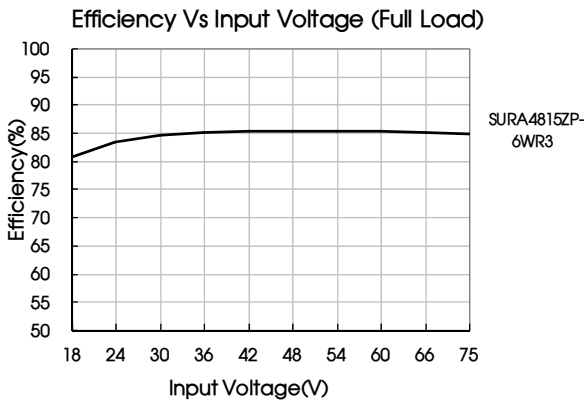
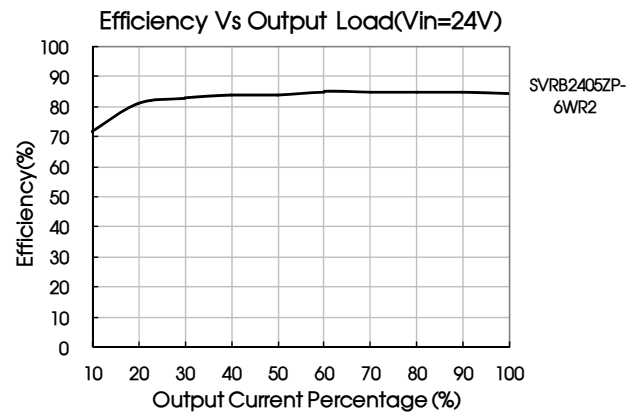
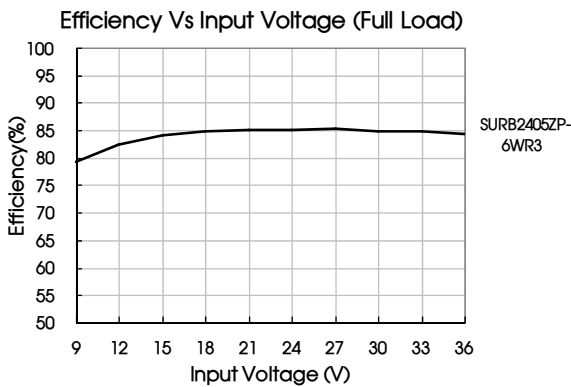

Fig. 1



DC/DC Converter

SURA_ZP-6WR3 & SURB_ZP-6WR3 Series

Design Reference

1. Typical application

All the DC/DC converters of this series are tested according to the recommended circuit (see Fig. 2) before delivery. If it is required to further reduce input and output ripple, properly increase the input & output of additional capacitors C_{in} and C_{out} or select capacitors of low equivalent impedance provided that the capacitance is no larger than the max. capacitive load of the product.

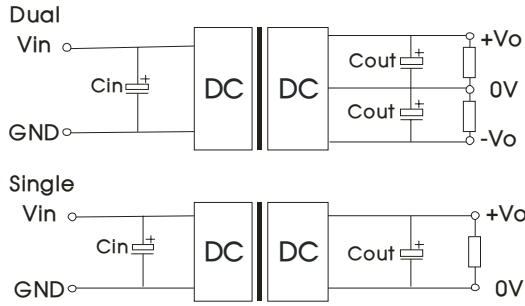

Fig. 2

Vin(VDC)	Cin	Cout
24	100 μ F	10 μ F
48	10 μ F ~47 μ F	10 μ F

2. EMC solution-recommended circuit

Parameter description:

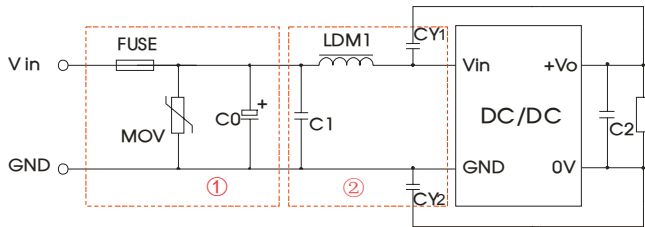

Fig. 3

Notes: Part ① in the Fig. 3 is used for EMS test and part ② for EMI filtering; selected based on needs.

Model	Vin:24V	Vin:48V
FUSE	Choose according to actual input current	
MOV	S14K35	S14K60
C0	330 μ F/50V	330 μ F/100V
C1	1 μ F/50V	1 μ F/100V
C2	Refer to the Cout in Fig.2	
LDM1	4.7 μ H	
CY1	1nF/2KV	
CY2	1nF/2KV	

EMC solution-recommended circuit PCB layout

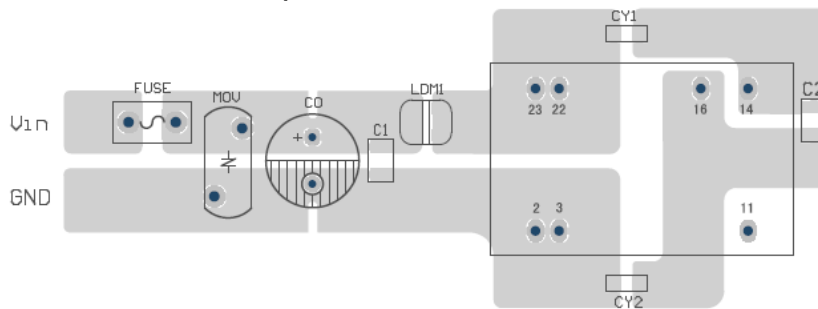

Fig. 4

Note: the min. distance of the bonding pads between input & output isolation capacitors (CY1/CY2) shall be ≥ 2 mm.

3. The product does not support output in parallel with power per liter

DC/DC Converter

SURA_ZP-6WR3 & SURB_ZP-6WR3 Series

Dimensions and Recommended Layout

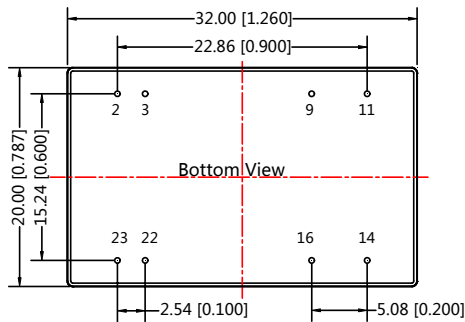
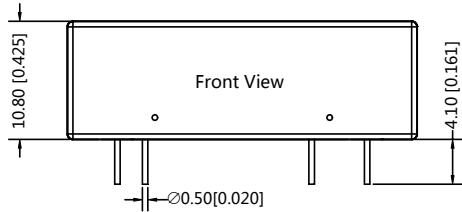

Note:
 Unit :mm[inch]
 Pin diameter tolerances :±0.10[±0.004]
 General tolerances:±0.50[±0.020]

THIRD ANGLE PROJECTION

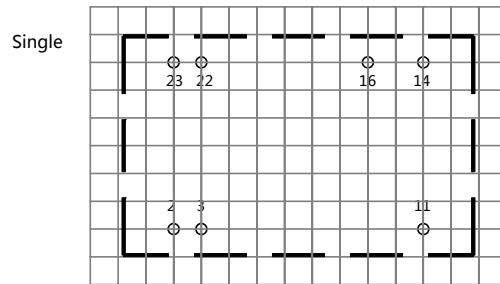
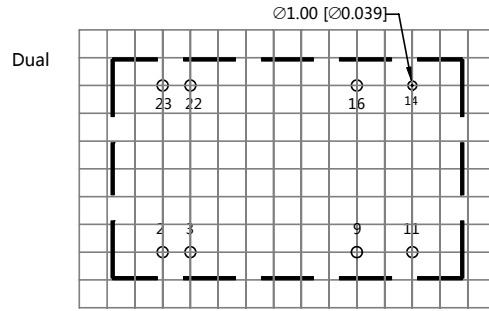

Note:Grid 2.54*2.54mm

Pin	Single	Dual
2,3	GND	GND
9	No Pin	0V
11	NC	-Vo
14	+Vo	+Vo
16	0V	0V
22,23	Vin	Vin

NC: No Connection

Notes:

1. Packing Information please refer to 'Product Packing Information'. Packing bag number : 58210008;
2. Recommended used in more than 5% load, if the load is lower than 5%, then the ripple index of the product may exceed the specification, but does not affect the reliability of the product;
3. The unbalance degree of the recommended dual output module load: ≤ 5%; if the degree exceeds ±5%, then the product performances cannot be guaranteed to comply with all the performance indicators in the manual, and please directly contact our technicians for specific information;
4. The max. capacitive load should be tested within the input voltage range and under full load conditions;
5. Unless otherwise specified, data in this datasheet should be tested under the conditions of Ta=25°C, humidity<75% when inputting nominal voltage and outputting rated load;
6. All index testing methods in this datasheet are based on our Company's corporate standards;
7. The performance indexes of the product models listed in this datasheet are as above, but some indexes of non-standard model products will exceed the above-mentioned requirements, and please directly contact our technicians for specific information;
8. We can provide product customization service;
9. Specifications of this product are subject to changes without prior notice.