

SCHMID-M

SR6-3W Series

3W 2:1 Regulated Single & Dual output

Features

- Wide 2:1 Input Range
- Full SMD Technology
- 1500 VDC Isolation, Up to 3500 VDC
- Continuous Short Circuit Protection
- Efficiency up to 82%
- -40 ~ 85°C Operating Temperature
- Plastic Case Standard, Optional Metal Case



The SR6 series is a family of cost effective 3W single & dual output DC-DC converters. These converters combine Plastic case in a 24-pin DIL package with high performance features such as 1500VDC ~ 3500VDC input/output isolation voltage, continuous short circuit protection with automatic restart and high line / load regulation. Devices are encapsulated using flame retardant resin. Input voltages of 5, 12, 24 and 48 with output voltage of 5, 7.2, 9, 12, 15, 18, 24, ± 5 , ± 7.2 , ± 9 , ± 12 , ± 15 , ± 18 and ± 24 Vdc. High performance features include high efficiency operation up to 82% and output voltage accuracy of $\pm 1\%$ maximum.

All specifications typical at $T_a=25^\circ\text{C}$, nominal input voltage and full load unless otherwise specified

OUTPUT SPECIFICATIONS	
Voltage accuracy	$\pm 1\%$, max.
Line regulation	$\pm 0.5\%$, max.
Load regulation	$\pm 0.5\%$, max.
Ripple & noise (20 MHz bandwidth)(1)	60mV pk-pk, max.
Short circuit protection	Continuous
Temperature coefficient	$\pm 0.02\%/^\circ\text{C}$
Capacitor load(2)	See table, max.

INPUT SPECIFICATIONS	
Voltage Range	See table
Input Current (No Load)	See table, max.
Input Current (Full Load)	See table, typ.
Input Filter	PI Type
Input Reflected Ripple Current(3)	35mA pk-pk, typ.

GENERAL SPECIFICATIONS	
Efficiency	See table, typ.
I/O Isolation Voltage(60sec)	
Input/Output	1500~3500Vdc
Metal Case/Input & Output	1000Vdc
I/O Isolation Capacitance	60 pF typ.
I/O Isolation Resistance	1000M Ohm, min.
Switching Frequency	100~400kHz, typ.
Humidity	95% rel H
Reliability Calculated MTBF(MIL-HDBK-217 F)	>1Mhrs
Safety Standard : (designed to meet)	IEC 60950-1

ENVIRONMENT SPECIFICATIONS	
Operating Temperature	-40°C~85°C
Maximum Case Temperature	100°C
Storage Temperature	-40°C~125°C
Cooling	Nature Convection

PHYSICAL SPECIFICATIONS	
Case Material	Non-conductive Black Plastic(UL94V-0 rated)
	Nickel-coated Copper
Base Material	Non-conductive Black Plastic(UL94V-0 rated)
Pin Material	$\Phi 0.5\text{mm}$ Brass Solder-coated
Potting Material	Epoxy (UL94V-0 rated)
Weight	12.5g(Plastic Case)/17.0g(Metal Case)
Dimensions	1.25"x0.8"x0.4"

ABSOLUTE MAXIMUM RATINGS(4)	
These are stress ratings. Exposure of devices to any of these conditions may adversely affect long-term reliability.	
Input Surge Voltage(100mS)	
5 Models	15 Vdc, max.
12 Models	24 Vdc, max.
24 Models	40 Vdc, max.
48 Models	80 Vdc, max.
Soldering Temperature (1.5mm from case 10sec max.)	260°C max.

EMC SPECIFICATIONS		
Radiated Emissions	EN55022	CLASS A
Conducted Emissions (7)	EN55022	CLASS A
ESD	IEC 61000-4-2	Perf. Criteria A
RS	IEC 61000-4-3	Perf. Criteria A
EFT (8)	IEC 61000-4-4	Perf. Criteria A
Surge (8)	IEC 61000-4-5	Perf. Criteria A
CS	IEC 61000-4-6	Perf. Criteria A
PFMF	IEC 61000-4-8	Perf. Criteria A

SR6 - 3W 2:1 Regulated Single & Dual Output

PART NUMBER STRUCTURE

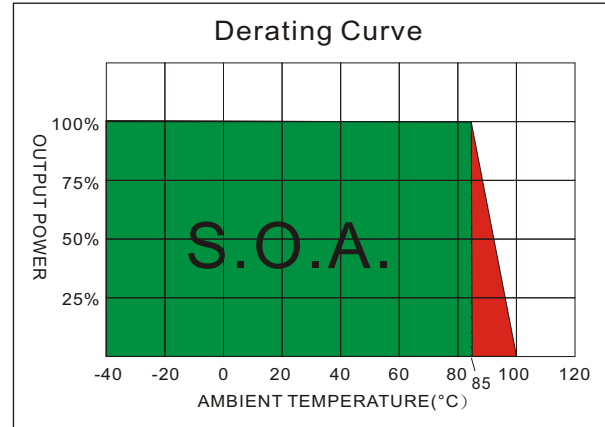
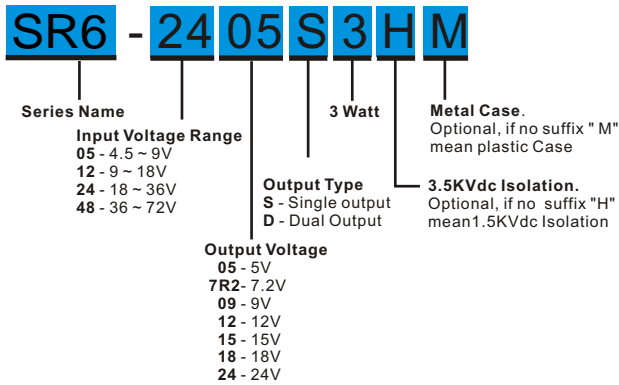

MODEL SELECTION GUIDE

MODEL NUMBER	INPUT Voltage Range (Vdc)	INPUT Current		OUTPUT Voltage (Vdc)	OUTPUT Current		EFFICIENCY @FL (% , typ.)	Capacitor Load @FL (µF, max.)
		No-Load (mA, max.)	Full Load (mA, typ.)		Min. load (mA)	Full load (mA)		
SR6-0505S3	4.5-9	40	857	5	150	600	70	2200
SR6-057R2S3	4.5-9	40	833	7.2	104	417	72	1000
SR6-0509S3	4.5-9	40	833	9	83	333	72	470
SR6-0512S3	4.5-9	40	810	12	63	250	74	470
SR6-0515S3	4.5-9	40	810	15	50	200	74	470
SR6-0518S3	4.5-9	40	810	18	42	167	74	220
SR6-0524S3	4.5-9	40	857	24	31	125	70	220
SR6-0505D3	4.5-9	40	869	±5	±75	±300	69	±1000
SR6-057R2D3	4.5-9	40	896	±7.2	±52	±208	67	±220
SR6-0509D3	4.5-9	40	857	±9	±42	±167	70	±220
SR6-0512D3	4.5-9	40	833	±12	±31	±125	72	±220
SR6-0515D3	4.5-9	40	810	±15	±25	±100	74	±220
SR6-0518D3	4.5-9	40	810	±18	±21	±83	74	±220
SR6-0524D3	4.5-9	40	857	±24	±16	±63	70	±100
SR6-1205S3	9-18	20	328	5	150	600	76	2200
SR6-127R2S3	9-18	20	338	7.2	104	417	74	1000
SR6-1209S3	9-18	20	324	9	83	333	77	470
SR6-1212S3	9-18	20	316	12	63	250	79	470
SR6-1215S3	9-18	20	316	15	50	200	79	470
SR6-1218S3	9-18	20	316	18	42	167	79	220
SR6-1224S3	9-18	20	316	24	31	125	79	220
SR6-1205D3	9-18	20	329	±5	±75	±300	76	±1000
SR6-127R2D3	9-18	20	325	±7.2	±52	±208	77	±220
SR6-1209D3	9-18	20	325	±9	±42	±167	77	±220
SR6-1212D3	9-18	20	316	±12	±31	±125	79	±220
SR6-1215D3	9-18	20	316	±15	±25	±100	79	±220
SR6-1218D3	9-18	20	321	±18	±21	±83	78	±220
SR6-1224D3	9-18	20	316	±24	±16	±63	79	±100
SR6-2405S3	18-36	12	156	5	150	600	80	2200
SR6-247R2S3	18-36	12	162	7.2	104	417	77	1000

Suffix "H" means 3.5KVdc isolation

Suffix "M" means Metal Case instead of standard Plastic case

SR6 - 3W 2:1 Regulated Single & Dual Output

MODEL NUMBER	INPUT Voltage Range (Vdc)	INPUT Current		OUTPUT Voltage (Vdc)	OUTPUT Current		EFFICIENCY @FL (% typ.)	Capacitor Load @FL (µF, max.)
		No-Load (mA, max.)	Full Load (mA, typ.)		Min. load (mA)	Full load (mA)		
SR6-2409S3	18-36	12	156	9	83	333	80	470
SR6-2412S3	18-36	12	152	12	62	250	82	470
SR6-2415S3	18-36	12	152	15	50	200	82	470
SR6-2418S3	18-36	12	158	18	42	167	79	220
SR6-2424S3	18-36	12	156	24	31	125	80	220
SR6-2405D3	18-36	12	156	±5	±75	±300	80	±1000
SR6-247R2D3	18-36	12	160	±7.2	±52	±208	78	±220
SR6-2409D3	18-36	12	158	±9	±42	±167	80	±220
SR6-2412D3	18-36	12	152	±12	±31	±125	82	±220
SR6-2415D3	18-36	12	152	±15	±25	±100	82	±220
SR6-2418D3	18-36	12	156	±18	±21	±83	80	±220
SR6-2424D3	18-36	12	156	±24	±16	±63	80	±100
SR6-4805S3	36-72	8	81	5	150	600	77	2200
SR6-487R2S3	36-72	8	80	7.2	104	417	78	1000
SR6-4809S3	36-72	8	80	9	83	333	78	470
SR6-4812S3	36-72	8	78	12	63	250	80	470
SR6-4815S3	36-72	8	78	15	50	200	80	470
SR6-4818S3	36-72	8	81	18	42	167	77	220
SR6-4824S3	36-72	8	78	24	31	125	80	220
SR6-4805D3	36-72	8	80	±5	±75	±300	78	±1000
SR6-487R2D3	36-72	8	80	±7.2	±52	±208	78	±220
SR6-4809D3	36-72	8	79	±9	±42	±167	79	±220
SR6-4812D3	36-72	8	78	±12	±31	±125	80	±220
SR6-4815D3	36-72	8	78	±15	±25	±100	80	±220
SR6-4818D3	36-72	8	80	±18	±21	±83	78	±220
SR6-4824D3	36-72	8	78	±24	±15.8	±63	80	±100

Suffix "H" means 3.5KVdc isolation
 Suffix "M" means Metal Case instead of standard Plastic case

TEST CONFIGURATIONS

EMI Filter

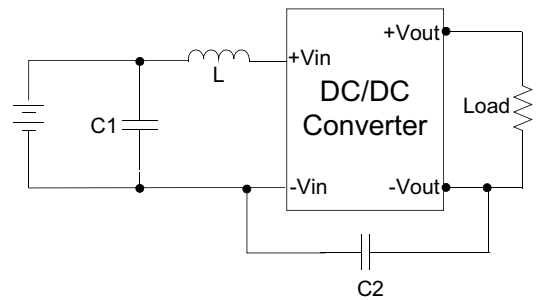

Input filter components (C1,C2, L) are used to help meet conducted emissions requirement for the module. These components should be mounted as close as possible to the module; and all leads should be minimized to decrease radiated noise.

	C1	L	C2
SR6-05XXXXX	220µF/100V	12µH	
SR6-12XXXXX	220µF/100V	12µH	
SR6-24XXXXX	220µF/100V	12µH	MLCC 470PF
SR6-48XXXXX	220µF/100V	12µH	MLCC 470PF

SR6 - 3W 2:1 Regulated Single & Dual Output

NOTE

1. Typical value at nominal input voltage and full load.
2. Test by nominal input voltage and constant resistor load.
3. Measured Input reflected ripple current with a simulated source inductance of 12μH.
4. Exceeding the absolute ratings of the unit could cause damage. It is not allowed for continuous operating.
5. Operation under no-load conditions will not damage these devices, however they may not meet all listed specifications.
6. It's necessary to add minimum capacitor in output for some models, please check single model datasheet for detail value.
7. Input filter components are be required to help meet conducted emission class A, which application refer to the EMI Filter of design & feature configuration.
8. An external filter capacitor is required if the module has to meet IEC61000-4-4 and IEC61000-4-5.
The filter capacitor SCHMID-M suggest: Nippon - chemi con KY series, 220μF/100V.

MECHANICAL SPECIFICATIONS FOR HIGH ISOLATION MODEL

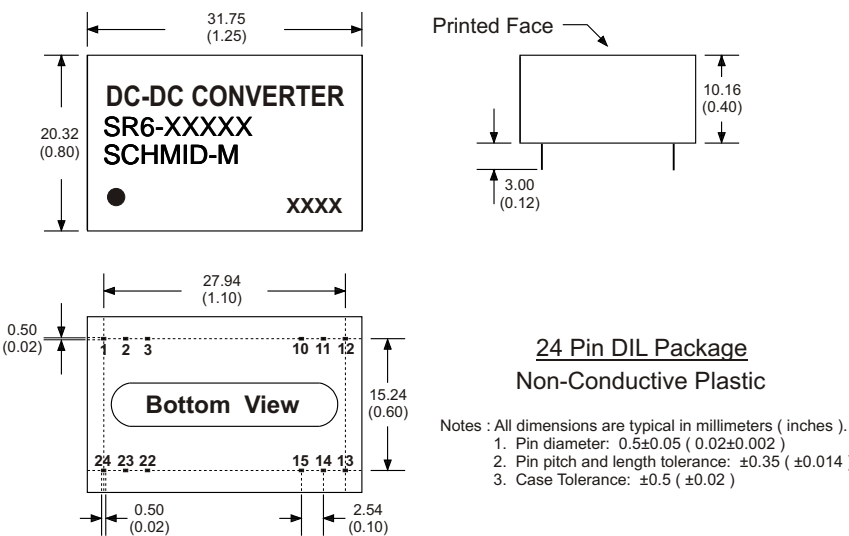

PIN CONNECTIONS				
PIN NUMBER	SINGLE	DUAL	SINGLE-H	DUAL-H
1	+V Input	+V Input	N.P.	N.P.
2	N.C.	-V Output	-V Input	-V Input
3	N.C.	Common	-V Input	-V Input
9	N.P.	N.P.	N.P.	Common
10	-V Output	Common	N.P.	N.P.
11	+V Output	+V Output	N.C.	-V Output
12	-V Input	-V Input	N.P.	N.P.
13	-V Input	-V Input	N.P.	N.P.
14	+V Output	+V Output	+V Output	+V Output
15	-V Output	Common	N.P.	N.P.
16	N.P.	N.P.	-V Output	Common
22	N.C.	Common	+V Input	+V Input
23	N.C.	-V Output	+V Input	+V Input
24	+V Input	+V Input	N.P.	N.P.

MECHANICAL SPECIFICATIONS

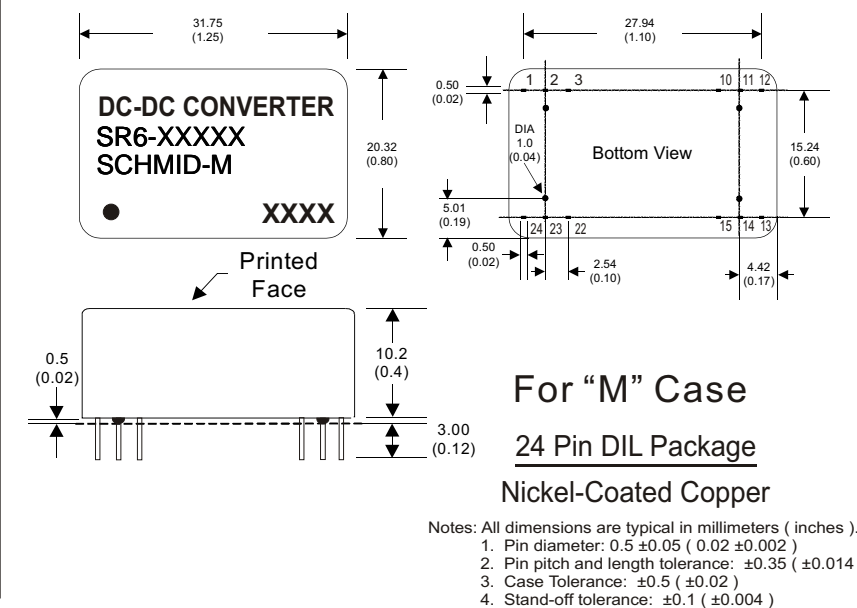

PIN CONNECTIONS				
PIN NUMBER	SINGLE	DUAL	SINGLE-H	DUAL-H
1	+V Input	+V Input	N.P.	N.P.
2	N.C.	-V Output	-V Input	-V Input
3	N.C.	Common	-V Input	-V Input
9	N.P.	N.P.	N.P.	Common
10	-V Output	Common	N.P.	N.P.
11	+V Output	+V Output	N.C.	-V Output
12	-V Input	-V Input	N.P.	N.P.
13	-V Input	-V Input	N.P.	N.P.
14	+V Output	+V Output	+V Output	+V Output
15	-V Output	Common	N.P.	N.P.
16	N.P.	N.P.	-V Output	Common
22	N.C.	Common	+V Input	+V Input
23	N.C.	-V Output	+V Input	+V Input
24	+V Input	+V Input	N.P.	N.P.