

SBW-2W Series

2W 4:1 Regulated Single & Dual output

SCHMID-M

Features

- 9 Pin SIL
- Wide 4:1 Input Range
- Full SMD Technology
- 1500 VDC Isolation
- Continuous Short Circuit Protection
- Efficiency up to 85%
- -40°C ~ 75°C Operation Temperature Range
- Remote on/off Control



The SBW series is a family of cost effective 2W single & dual output DC-DC converters. These converters combine non-conductive black plastic package in a 9-pin SIL compatible case with high performance features such as 1500 VDC input/output isolation voltage, continuous short circuit protection with automatic restart and high line / load regulation. Wide range devices operate over 4:1 input voltage range providing stable output voltage. Devices are encapsulated using flame retardant resin. Input voltages of 24 and 48 with output voltage of 3.3, 5, 12, 15, ± 5 , ± 12 , ± 15 Vdc. High performance features include high efficiency operation up to 85% and output voltage accuracy of $\pm 1\%$ maximum.

All specifications typical at $T_a=25^\circ\text{C}$, nominal input voltage and full load unless otherwise specified

OUTPUT SPECIFICATIONS	
Voltage Accuracy	$\pm 1\%$
Maximun Output Current	See table
Line Regulation	$\pm 0.5\%$, max.
Load Regulation (1)	(From 10% to 100% Loading) $\pm 0.5\%$, max. (From 0% to 100% Loading) $V_{out}=12\text{V}$ and 15V $\pm 0.5\%$, max. $V_{out}=3.3\text{V}$ and 5V $\pm 1.0\%$, max.
Cross Regulation (Dual Output) (2)	$\pm 5\%$
Ripple & Noise (20 Mhz bandwidth)(3)	50mVpp, max.
Short Circuit Protection	Indefinite(hiccup) (Automatic Recovery)
Temperature Coefficient	$\pm 0.002\%/^\circ\text{C}$
Capacitive Load(4)	See table
Transient Recovery Time (5)	300us, typ.
Transient Response Deviation(5)	$\pm 3\%$, max.

INPUT SPECIFICATIONS	
Voltage Range	See table
Start up Time(Nominal V_{in} and constant resistive load)	10mS, typ.
Max. Input Current	See table
No-Load Input Current	See table
Input Filter	Capacitor
Input Reflected Ripple Current(6)	20mA pk-pk
Remote on/off	
ON:	0 ~ 0.6Vdc or open circuit
OFF:	2.7~15.0Vdc
Off stand by input current(Nominal V_{in})	5mA max.

ABSOLUTE MAXIMUM RATINGS(7)	
These are stress ratings. Exposure of devices to any of these conditions may adversely affect long-term reliability.	
Input Surge Voltage(100ms max)	
24 Models	50Vdc, max.
48 Models	100Vdc, max.
Soldering Temperature	260°C, max.
(1.5mm from case 10 sec. max.)	

PHYSICAL SPECIFICATIONS	
Case Material	Non conductive black plastic
Potting Material	Epoxy (UL94V-0 rated)
Pin Material	C5191R-H Solder-coated
Weight	6.5g, typ
Dimensions	1.02"x0.36"x0.49"

GENERAL SPECIFICATIONS	
Efficiency	See table, typ.
I/O Isolation Voltage (60 sec)	1500Vdc
I/O Isolation Capacity	500 pF, max.
I/O Isolation Resistance	1000M Ohm, min.
Switching Frequency	250kHz, typ.
Humidity	95%relH
Reliability Calculated MTBF(MIL-HDBK-217 F)	>1.212 Mhrs@ 25°C
Safety Standard(designed to meet)	IEC60950

ENVIRONMENT SPECIFICATIONS	
Operating Temperature	-40°C ~ +85°C(See Derating Curve) -40°C ~ +75°C(For 100% load)
Maximum Case Temperature	100°C
Storage Temperature	-40°C~125°C
Cooling	Nature Convection

EMC CHARACTERISTICS		
Conducted Emissions (8)	EN55022	CLASS A
Radiated Emissions	EN55022	CLASS A
ESD	IEC 61000-4-2	Perf. Criteria A
RS	IEC 61000-4-3	Perf. Criteria A
EFT(9)	IEC 61000-4-4	Perf. Criteria A
Surge(9)	IEC 61000-4-5	Perf. Criteria B
CS	IEC 61000-4-6	Perf. Criteria A
PFMF	IEC 61000-4-8	Perf. Criteria A

SBW - 2W 4:1 Regulated Single & Dual output

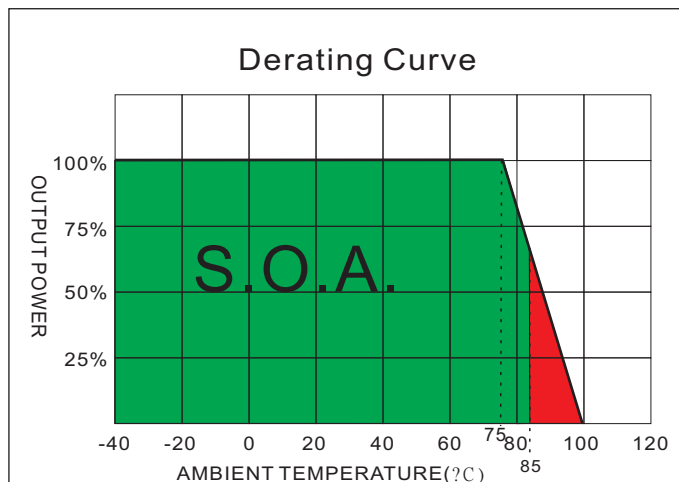
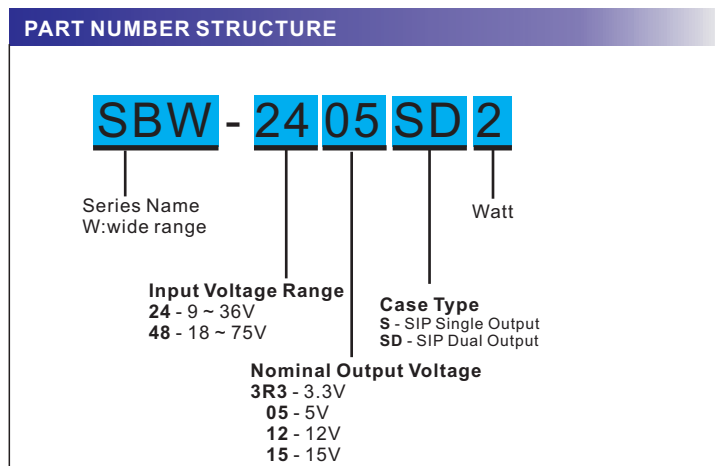

MODEL SELECTION GUIDE

MODEL NUMBER	INPUT Voltage Range (Vdc)	INPUT Current		OUTPUT Voltage (Vdc)	OUTPUT Current		EFFICIENCY @FL(%)	Capacitor Load(uF)
		No-Load (mA)	Full Load (mA)		Min. load (mA)	Full load (mA)		
SBW-243R3S2	9-36	10	92	3.3	0	500	75	2200uF
SBW-2405S2	9-36	10	103	5	0	400	81	1000uF
SBW-2412S2	9-36	10	100	12	0	165	84	165uF
SBW-2415S2	9-36	10	98	15	0	135	85	100uF
SBW-483R3S2	18-75	5	46	3.3	0	500	75	2200uF
SBW-4805S2	18-75	5	53	5	0	400	80	1000uF
SBW-4812S2	18-75	5	50	12	0	165	84	165uF
SBW-4815S2	18-75	5	50	15	0	135	84	100uF
SBW-2405SD2	9-36	10	103	±5	0	±200	81	470uF
SBW-2412SD2	9-36	10	101	±12	0	±85	83	100uF
SBW-2415SD2	9-36	15	102	±15	0	±65	82	47uF
SBW-4805SD2	18-75	5	53	±5	0	±200	80	470uF
SBW-4812SD2	18-75	5	52	±12	0	±85	81	100uF
SBW-4815SD2	18-75	5	50	±15	0	±65	84	47uF

NOTE

1. Operation at no load condition will not damage the product ; however, it will not meet all specifications.
2. One load is 25% to 100% load, the other load is 100% load, the output voltage variable rate is within ±5%.
3. Operation at lower load and no load may have bigger ripple and noise.
4. Test by minimal Vin and constant resistive load.
5. Test by normal Vin and 100%-25% load,25% load step change;If the output voltage is 3.3V then the Transient Response Deviation is ±5%.
6. Measured Input reflected ripple current with a simulated source inductance of 12uH and a source capacitor Cin(47uF, ESR<1.0Ω at 100KHz).
7. Exceeding the absolute ratings of the unit could cause damage. It's not allowed for continuous operating ratings.
8. Input filter components are be required to help meet conducted emission class A, which application refer to the EMI Filter of design & feature configuration.
9. An external filter capacitor is required if the module has to meet IEC61000-4-4 and IEC61000-4-5.
The filter capacitor SCHMID-M suggest: Nippon - chemi - con KY series, 220uF/100V.

TEST CONFIGURATIONS

Input Reflected Ripple Current Test Step

Input reflected ripple current is measured through a source inductor L_{in} (12uH) and a source capacitor C_{in} (47uF, ESR<1.0Ω at 100KHz) at nominal input and full load.

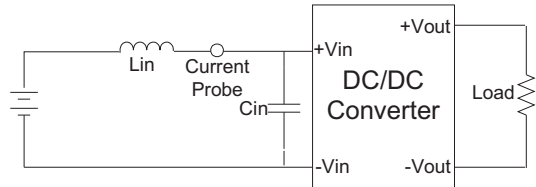

EMI Filter

Input filter components (C1, L) are used to help meet conducted emissions requirement for the module. These components should be mounted as close as possible to the module; and all leads should be minimized to decrease radiated noise.

Output Ripple & Noise Measurement Test

The Scope measurement bandwidth is 20MHz.

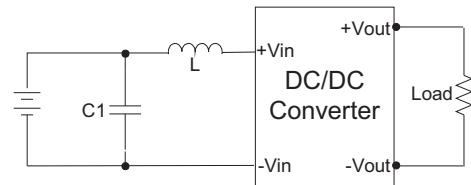
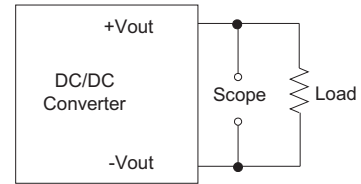

	C1	L
SVBW-24XXXXXX	1210,225K/100V,X7R * 2PCS	6.8uH
SVBW-48XXXXXX	1210,105K/100V,X7R	56uH

CTRL Module ON / OFF

ON: 0~0.6Vdc or open circuit
OFF: 2.7Vdc~15.0Vdc

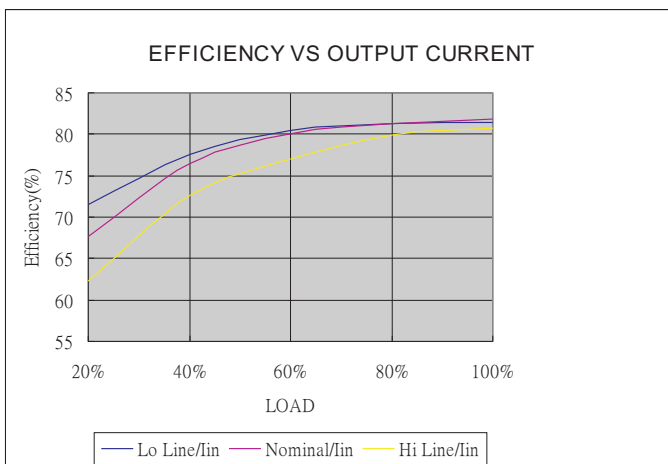
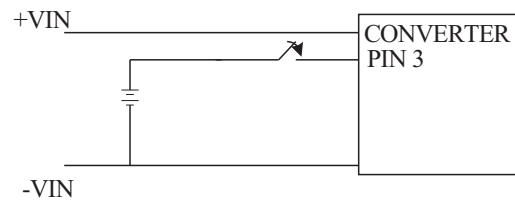

24 Models

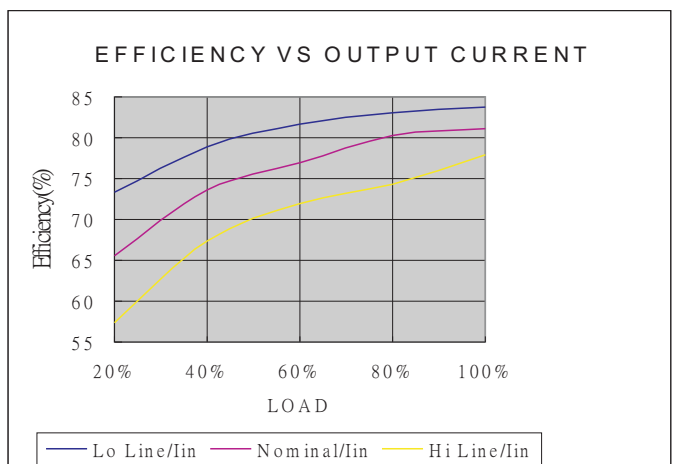

48 Models

SBW - 2W 4:1 Regulated Single & Dual output

MECHANICAL SPECIFICATIONS

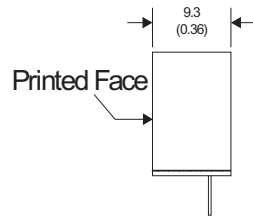
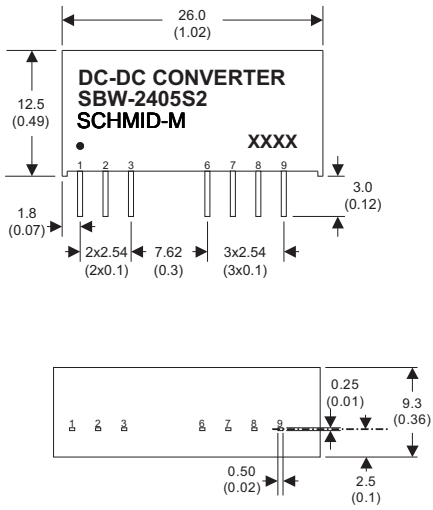

9 Pin SIL Package
Non-Conductive Plastic

PIN CONNECTIONS		
PIN NUMBER	SINGLE	DUAL
1	-V Input	-V Input
2	+V Input	+V Input
3	Remote On/Off	Remote On/Off
6	+V Output	+V Output
7	N.C.	Common
8	N.C.	N.C.
9	-V Output	-V Output

- Notes: All dimensions are typical in millimeters (inches).
1. Pin diameter: 0.5 ± 0.05 (0.02 ± 0.002)
 2. Pin pitch and length tolerance: ± 0.35 (± 0.014)
 3. Case Tolerance: ± 0.5 (± 0.02)