

Ferrites and Accessories

Standard Ferrite Cores with Distributed Air Gaps – ETD, PQ, E Cores

Applications

- LLC transformers and resonance chokes
- Flyback transformers
- Storage chokes
- PFC chokes for active PFCs
 - Boundary Conduction Mode (BCM)
 - Critical Conduction Mode (CrCM)
 - Discontinuous Conduction Mode (DCM)
- General Power Conversion where large air gap is needed

Standards

ETD, PQ and E Cores with distributed air gaps and their corresponding accessories are now available as standard catalog types.

Application fields

- On-board chargers and DC-DC converters for xEV
- EV charging stations
- Solar inverters
- Industrial SMPS
- Telecom / Server SMPS
- UPS

Benefits

- Significantly increased power density
- Reduction of losses caused by proximity effect and eddy currents
- Improvement of thermal performance
- Temperature stability up to 180 °C

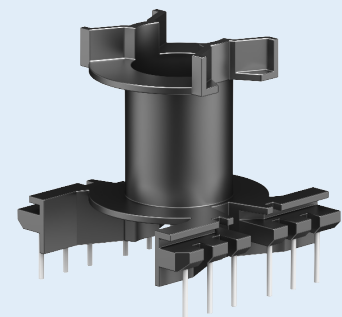
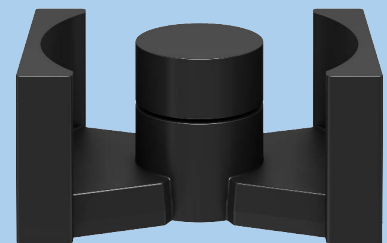

Distributed Air Gaps Standards



Core types and accessories

With the new standards for ferrite cores with distributed air gaps TDK Electronics offers the marketplace an opportunity to follow the trend of downsizing and increasing power density. In addition, DG cores give the possibility to optimize the design of magnetics in terms of efficiency and thermal performance.

Internal construction of TDK's Distributed Gapped Cores are temperature rated up to 180 °C. All DG cores can be used with common accessories (coil formers and mounting hardware).

Note: All coil formers are available with different pin numbers or without pins on request

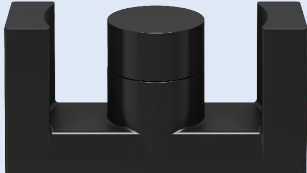
Size	Material	A _L value	Part number	ETD cores and accessories
ETD 39/20/13DG	N87 N87	100 nH 150 nH	B66363Q0100K187 B66363Q0150K187	 <p>Delivery mode in pieces</p>
ETD 49/25/16DG	N87 N87	100 nH 250 nH	B66367Q0100K187 B66367Q0250K187	
ETD 59/31/22DG	N87 N87 N87	100 nH 250 nH 400 nH	B66397Q0100K187 B66397Q0250K187 B66397Q0400K187	

Size	Accessories	Sections	Pins	Insulation system (to IEC 60085)	Flammability	Ordering code
ETD 39/20/13	Coil former Coil former Yoke	1 1 –	16 16 –	Class F – 155 °C Class H – 180 °C –	UL 94 V-0 UL 94 V-0 –	B66364B1016T001 B66364W1016T001 B66364A2000X000
ETD 49/25/16	Coil former Coil former Yoke	1 1 –	20 20 –	Class F – 155 °C Class H – 180 °C –	UL 94 V-0 UL 94 V-0 –	B66368B1020T001 B66368W1020T001 B66368A2000X000
ETD 59/31/22	Coil former Yoke	1 –	24 –	Class H – 180 °C –	UL 94 V-0 –	B66398W1024T001 B66398A2000X000

Size	Material	A _L value	Part number	PQ cores and accessories
PQ 32/30DG	N95 N95	100 nH 150 nH	B65879Q0100K095 B65879Q0150K095	 <p>Delivery mode in sets</p>
PQ 35/35DG	N95 N95	100 nH 150 nH	B65881Q0100K095 B65881Q0150K095	
PQ 50/50DG	N95 N95 N95	100 nH 250 nH 400 nH	B65981Q0100K095 B65981Q0250K095 B65981Q0400K095	
PQ 65/60DG	N95 N95 N95	100 nH 250 nH 400 nH	B65982Q0100K095 B65982Q0250K095 B65982Q0400K095	

Size	Accessories	Sections	Pins	Insulation system (to IEC 60085)	Flammability	Part number
PQ 32/30	Coil former	1	12	Class F – 155 °C	UL 94 V-0	B65880E2012D001
PQ 35/35	Coil former	1	12	Class H – 180 °C	UL 94 V-0	B65882B0012T001
PQ 50/50	Coil former	1	12	Class F – 155 °C	UL 94 V-0	B65982E0012D001
PQ 65/60	Coil former	1	16	Class H – 180 °C	UL 94 V-0	B65983E0016T001

Distributed Air Gaps Standards



Core types and accessories

Size	Material	A _L value	Ordering code	E cores and accessories		
E 32/16/9DG	N87 N87	60 nH 120 nH	B66229Q0060K187 B66229Q0120K187	 <p>Delivery mode in pieces</p>		
E 32/16/11DG	N87 N87	100 nH 150 nH	B66233Q0100K187 B66233Q0150K187			
E 55/28/21DG	N87 N87 N87	100 nH 250 nH 400 nH	B66335Q0100K187 B66335Q0250K187 B66335Q0400K187			
E 55/28/25DG	N87 N87 N87	100 nH 250 nH 400 nH	B66344Q0100K187 B66344Q0250K187 B66344Q0400K187			
E 65/32/27DG	N87 N87 N87	100 nH 250 nH 400 nH	B66387Q0100K187 B66387Q0250K187 B66387Q0400K187			
E 70/33/32DG	N87 N87 N87	100 nH 250 nH 400 nH	B66371Q0100K187 B66371Q0250K187 B66371Q0400K187			
Size	Accessories	Sections	Pins	Insulation system (to IEC 60085)	Flammability	Ordering code
E 32/16/9	Coil former Yoke	1 –	14 –	Class H – 180 °C –	UL 94 V-0 –	B66230A1114T001 B66230A2010X000
E 32/16/11	Coil former Yoke	1 –	14 –	Class H – 180 °C –	UL 94 V-0 –	B66230B1114T001 B66230A2010X000
E 55/28/21	Coil former	1	14	Class F – 155 °C	UL 94 V-0	B66252B0000M001
E 55/28/25	Coil former	1	–	Class H – 180 °C	UL 94 V-0	B66253B1000T001
E 65/32/27	Coil former	1	–	Class H – 180 °C	UL 94 V-0	B66388B1000T001
	Coil former	1	–	Class F – 155 °C	UL 94 V-0	B66388A2000T001
E 70/33/32	Coil former	1	–	Class H – 180 °C	UL 94 V-0	B66372B1000T001
	Coil former	1	–	Class F – 155 °C	UL 94 V-0	B66372A2000T001
	Coil former	1	–	Class B – 130 °C	UL 94 HB	B66372B2000T001

STEP files

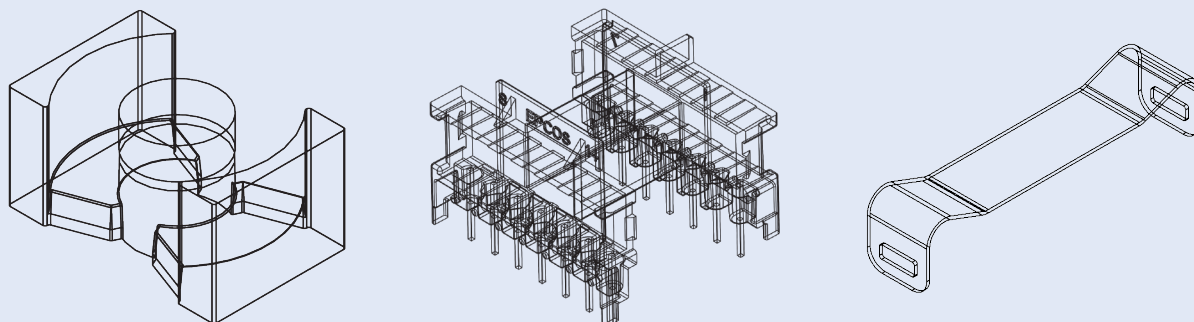

STEP files for all DG cores but also for the corresponding accessories are available on the web.

Distributed Air Gaps Thermal Performance

Hot spot comparison in the winding area on the ETD 29/16/10-N87 core set

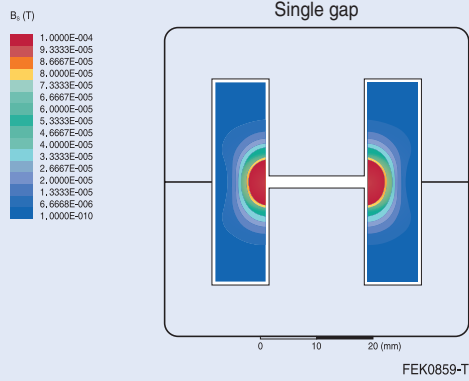

A single conventional air gap generates a hotspot in the winding due to the high concentration of fringing flux induced losses.

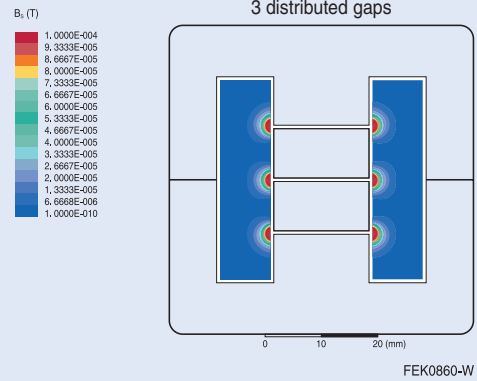

3 evenly distributed air gaps minimize the creation of a hotspot in the winding by lowering the fringing flux in the winding area.

Temperature comparison after 60 min of 3.4 A_{pp} @ 200 kHz with an ETD 29/16/10-N87 core set for a solid wire design

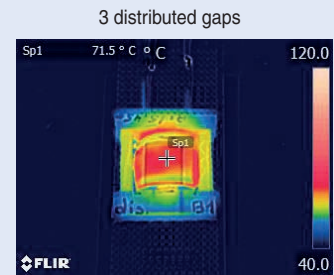
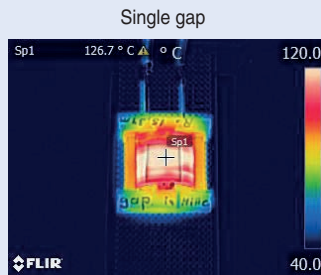

Thermal performance with 3.4 A_{pp} after 60 minutes

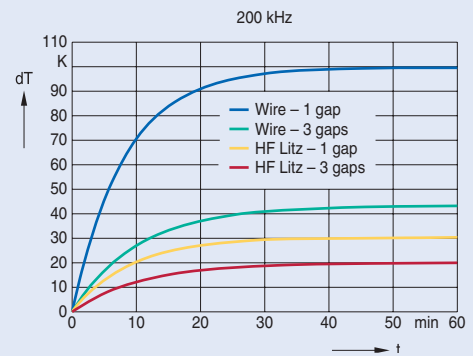
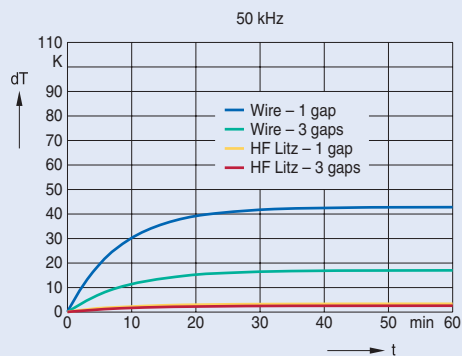

With distributed air gaps, solid wire designs may perform as well as litz wire designs but with a better R_{DC} .

The smaller fringing flux influence in the distributed gap set allows for more effective winding area.

Distributed air gaps lower the fringing flux by up to 70% and reduce heat generation.

Important information: Some parts of this publication contain statements about the suitability of our products for certain areas of application. These statements are based on our knowledge of typical requirements that are often placed on our products. We expressly point out that these statements cannot be regarded as binding statements about the suitability of our products for a particular customer application. It is incumbent on the customer to check and decide whether a product is suitable for use in a particular application. This publication is only a brief product survey which may be changed from time to time. Our products are described in detail in our data sheets. The *Important notes* (www.tdk-electronics.tdk.com/ImportantNotes) and the product-specific *Cautions and warnings* must be observed. All relevant information is available through our sales offices.