

# **Patron**

***Passive Elektronik***

## **EMC Shielding Catalogue**

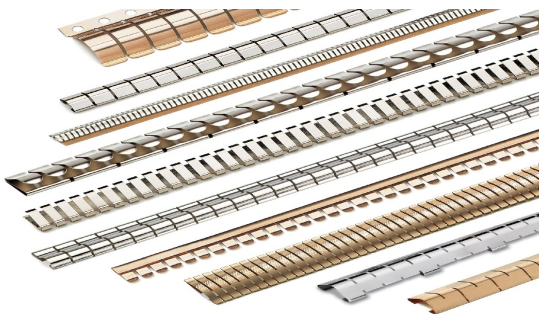
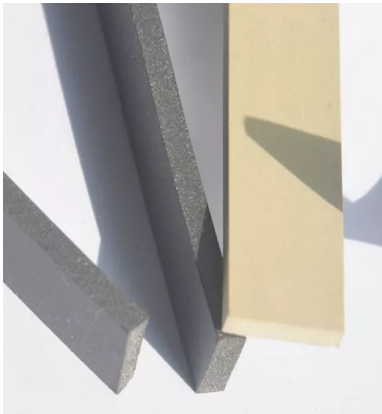
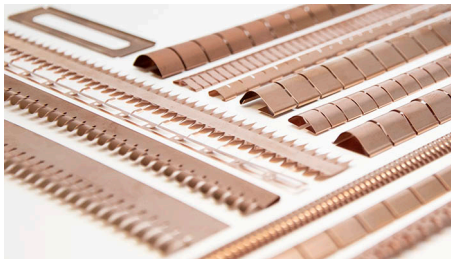

[www.patron-components.com](http://www.patron-components.com)

---

## CONTENT

3-4	CONTACT STRIPS
5	TWISTED CONTACT STRIPS
6	RFI-EMI SHIELDING
7-10	CLIP-ON GASKETS
11	CURVED FINGERS
12	SLIPPY FINGERS
13	GROUNDING AND SHIELD STRIPS
14	SLOT-MOUNT SHIELDS
15	TRACKS AND ACCESSORIES
16	ROUNDED SHIELDS
17-19	PCB CONTACT FINGERS
20	CONTACT STRIPS AND RINGS
21	DIN CONNECTOR GASKETS
22	SHIELDED CASES AND CABINETS
23	PCB SCREENS
24-27	ELASTOMERS
28	EMC ABSORBERS

### Ordering information

EXAMPLE

P/N:EMC BC 0000-00

Surface Finish and Plating  
Part Number  
Type of Material

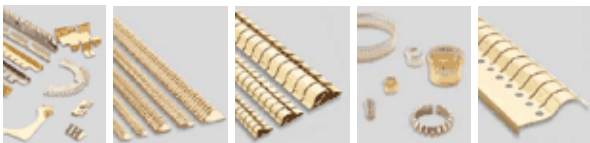

### Type of Material

BC: Beryllium Copper  
SS: Stainless Steel (where available)

### Surface Finish and Plating Codes

-02 bright finish  
-03 gold  
-04 silver  
-15 zinc chromate/clear  
-17 bright tin  
-19 bright nickel  
-00 customer specification

### CONTACT STRIPS

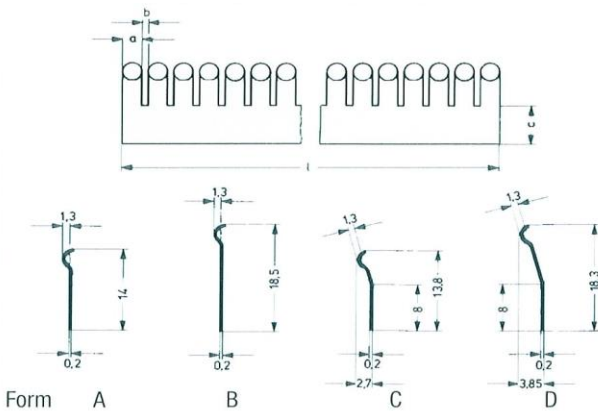

Form	a mm	b mm	c mm	l mm	Part no.
A	3	1	6.5	499	8101
B	3	1	6.5	499	8102
C	3	1	6.5	499	8103
D	3	1	6.5	499	8104

Surface Finish and Plating Codes: see page 16

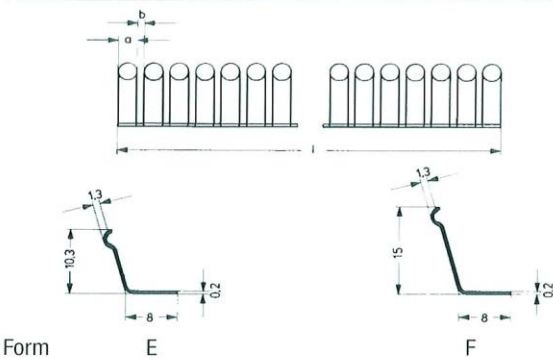

Form	a mm	b mm	c mm	l mm	Part no.
E	3	1	6.5	499	8105
F	3	1	6.5	499	8106

Surface Finish and Plating Codes: see page 16

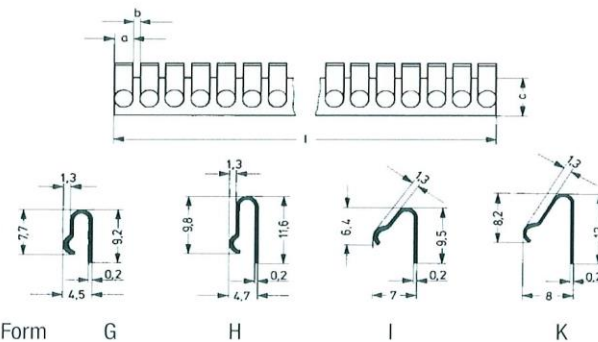

Form	a mm	b mm	c mm	l mm	Part no.
G	3	1	6.5	499	8107
H	3	1	6.5	499	8108
I	3	1	6.5	499	8109
K	3	1	6.5	499	8110

Surface Finish and Plating Codes: see page 16

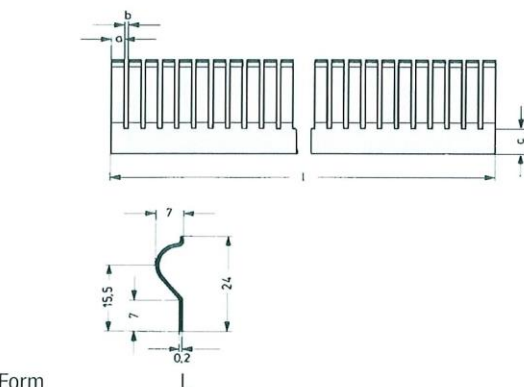

Form	a mm	b mm	c mm	l mm	Part no.
L	3	1	6.5	499	8111

Surface Finish and Plating Codes: see page 16

### CONTACT STRIPS

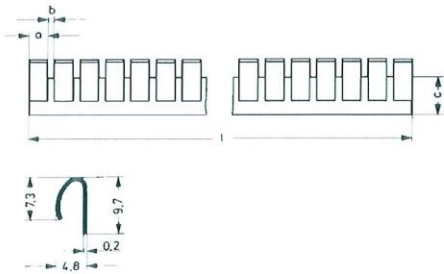

Form M

Form	a mm	b mm	c mm	l mm	Part no.
M	3	1	6.5	499	8112

Surface Finish and Plating Codes: see page 16

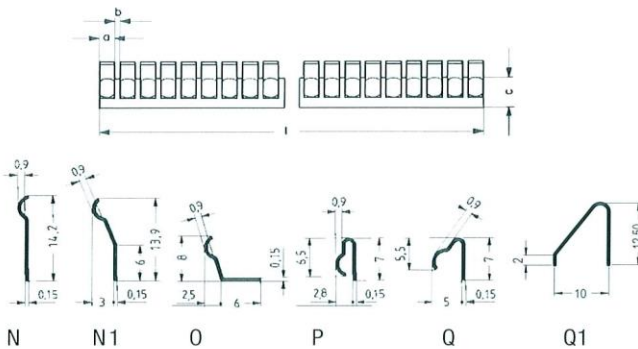

Form N N1 O P Q Q1

Form	a mm	b mm	c mm	l mm	Part no.
N	1.5	0.5	5.5	500	8113
N1	1.5	0.5	5.5	500	8113-1
O	1.5	0.5	5.5	500	8114
P	1.5	0.5	5.5	500	8115
Q	1.5	0.5	5.5	500	8116
Q1	1.5	0.5	5.5	500	8116-1

Surface Finish and Plating Codes: see page 16

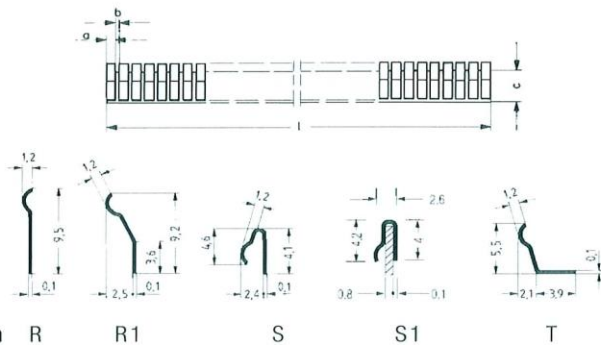

Form R R1 S S1 T

Form	a mm	b mm	c mm	l mm	Part no.
R	1	0.5	3.2	500	8117
R1	1	0.5	3.2	500	8117-1
S	1	0.5	3.2	500	8118
S1	1	0.5	3.2	406	8118-1
T	1	0.5	3.2	500	8119

Surface Finish and Plating Codes: see page 16

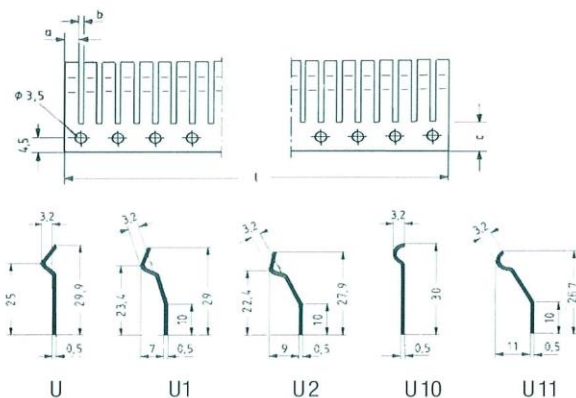

Form U U1 U2 U10 U11

Form	a mm	b mm	c mm	l mm	Part no.
U	3.03	0.97	9	503	8120
U1	3.03	0.97	9	503	8120-1
U2	3.03	0.97	9	503	8120-2
U10	3.03	0.97	9	503	8120-10
U11	3.03	0.97	9	503	8120-11

Surface Finish and Plating Codes: see page 16

### TWISTED CONTACT STRIPS

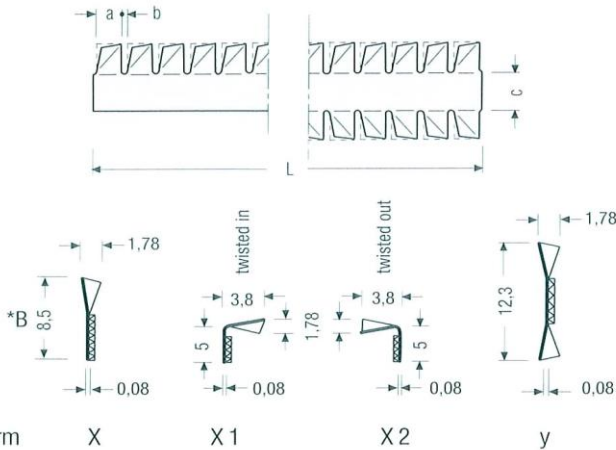

Strips with or without tape

Form	a	b	c	L	Part no.
X	3.8	0.4	4.8	499 mm	8501
	3.8	0.4	4.8	499 mm	8502
	3.8	0.4	4.8	499 mm	8503
	3.8	0.4	4.8	Endless	8504
X1	3.8	0.4	4.8	499 mm	8505
X2	3.8	0.4	4.8	499 mm	8506
Y	3.8	0.4	4.8	499 mm	8511
	3.8	0.4	4.8	499 mm	8512
	3.8	0.4	4.8	499 mm	8513
	3.8	0.4	4.8	Endless	8514

\* B: other dimensions available

Form

X

X1

X2

y

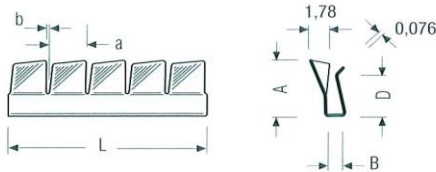

Form	a	b	A	B	D	L	Part no.
X3	3.8	0.4	4.8	1.0	4.1	407 mm	8601
	3.8	0.4	4.8	1.5	3.6	407 mm	8602
	3.8	0.4	4.8	2.0	3.2	407 mm	8603
X4	3.8	0.4	6.4	1.0	5.7	407 mm	8604
	3.8	0.4	6.4	1.5	5.3	407 mm	8605
	3.8	0.4	6.4	2.0	5.0	407 mm	8606

Also available with lances

Form X 3, X 4

### MINI-TWISTED CONTACT STRIPS

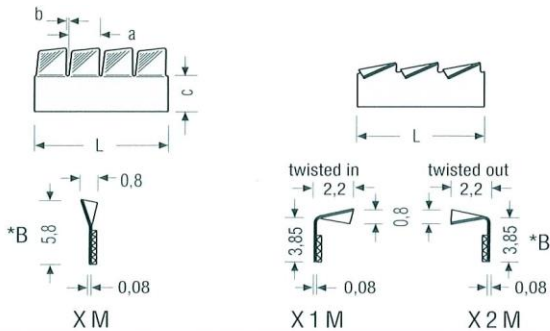

Strips with or without tape

Form	a	b	c	L	Part no.
XM	2.0	0.4	3.6	500 mm	8610
	2.0	0.4	3.6	610 mm	8611
	2.0	0.4	3.6	Endless	8613
X1M	2.0	0.4	3.6	610 mm	8614
X2M	2.0	0.4	3.6	610 mm	8615

\* B: other dimensions available

Form

XM

X1M

X2M

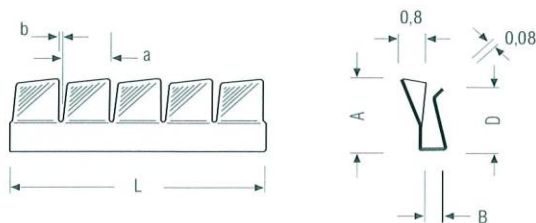

Form	a	b	A	B	D	L	Part no.
X5	2.0	0.4	3.8	1.0	3.7	405 mm	8616
X6	2.0	0.4	3.8	1.5	3.5	405 mm	8617
X7	2.0	0.4	4.7	1.0	4.5	405 mm	8618
X8	2.0	0.4	4.3	1.5	4.4	405 mm	8619
X9	2.0	0.4	5.9	1.0	4.7	405 mm	8620
X10	2.0	0.4	5.9	1.5	4.3	405 mm	8621

X 5 and X 6 also available with lances

Form X 5 to X 10

# RFI-EMI SHIELDING

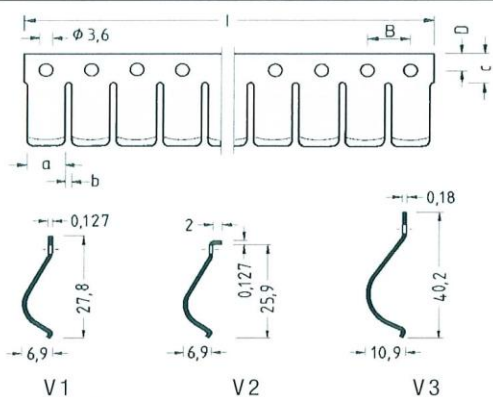
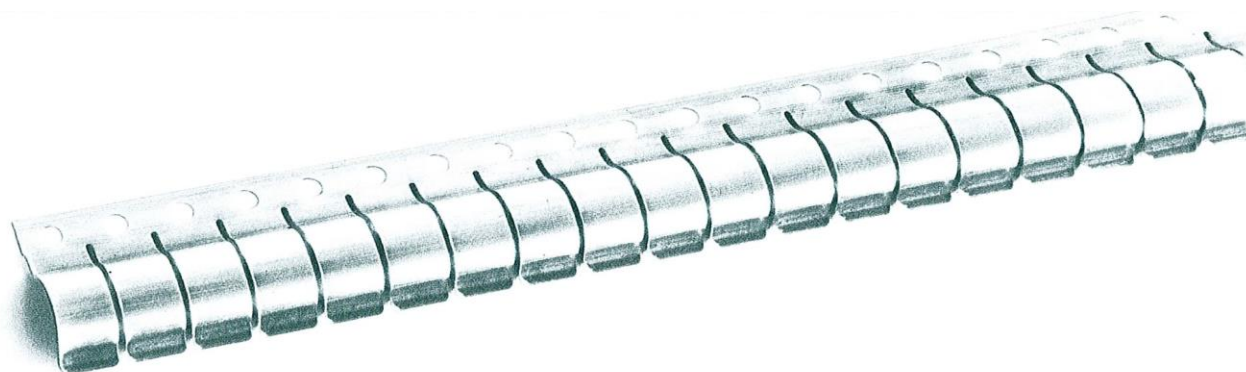

Form	a mm	b mm	c mm	B mm	D mm	l mm	Part no.
V1	8.5	1	6.7	9.5	4.00	504	8801*
	8.5	1	6.7	9.5	4.00	upon request	8802*
V2	8.5	1	6.7	9.5	4.00	504	8803*
	11.7	1	7.9	12.7	4.75	508	8804*
V3	11.7	1	7.9	12.7	4.75	upon request	8805*

\* Maximum compressed length

\* only available in CuBe

### Electrical Properties

Excellent shielding values > 100 dB at 100 MHz

### Application

Shielding of doors and other movable parts in shielded rooms and enclosures

### Monting

Using rivets, screws or soldering

### Ordering example

Contact strip Form V2 / Part no. 8801, Beryllium-Copper material, standard length

--> BC 8801-02

└─ bright finish

## CLIP-ON GASKETS

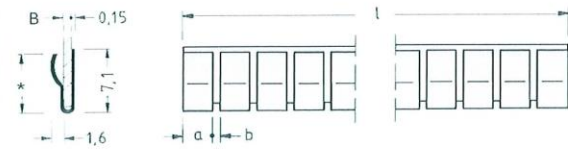

other heights than 1.6 mm available

- \*6.7 mm (Clip 0.8)
- \*6.6 mm (Clip 1.0)
- \*6.2 mm (Clip 1.5)

Form CL 1

Form	a mm	b mm	B mm	l mm	Part no.
CL 1	5.6	0.8	0.8	409	8901
CL 1-1	5.6	0.8	1.0	409	8901-1
CL 1-2	5.6	0.8	1.5	409	8901-2

Also available with D + T-Lances

Surface Finish and Plating Codes: see page 16

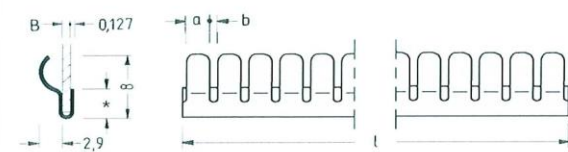

- \*CL2-1 = 7.8 mm
- \*CL2-2 = 4.75 mm

Form CL 2

Form	a mm	b mm	B mm	l mm	Part no.
CL 2	3.6	1.2	0.8	407	8902
CL 2-1	3.6	1.2	1.0	407	8902-1
CL 2-2	3.6	1.2	1.5	407	8902-2

Surface Finish and Plating Codes: see page 16

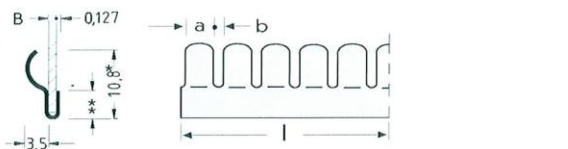

- \*CL3-3 = 10.5 mm
- \*\*CL3 = 5 mm
- \*\*CL3-1 = 4.8 mm
- \*\*CL3-2 = 4.3 mm
- \*\*CL3-3 = 4.5 mm

Form CL 3

Form	a mm	b mm	B mm	l mm	Part no.
CL 3	3.6	1.2	0.8	407	8903
CL 3-1	3.6	1.2	1.0	407	8903-1
CL 3-2	3.6	1.2	1.5	407	8903-2
CL 3-3	3.6	1.2	1.5	407	8903-3

Surface Finish and Plating Codes: see page 16

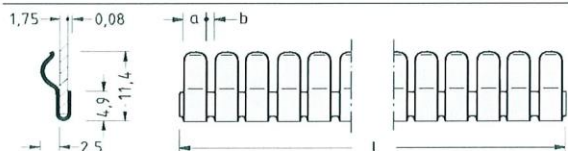

Form CL 4

Form	a mm	b mm	l mm	Part no.
CL 4	3.6	1.2	407	8904

Surface Finish and Plating Codes: see page 16

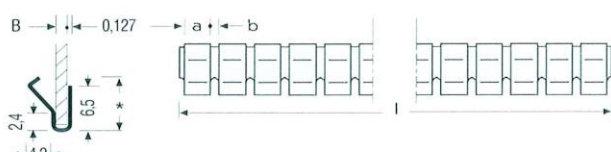

- \*CL5 = 8.40 mm
- \*CL5-1 = 8.10 mm
- \*CL5-2 = 8.15 mm

Form CL 5

Form	a mm	b mm	B mm	l mm	Part no.
CL 5	3.6	1.2	0.8	407	8905
CL 5-1	3.6	1.2	1.0	407	8905-1
CL 5-2	3.6	1.2	1.5	407	8905-2

Surface Finish and Plating Codes: see page 16

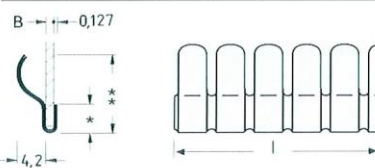

- \*CL6 = 4.8 mm
- \*CL6-1 = 5.1 mm
- \*CL6-2 = 4.8 mm
- \*\*CL6 = 14.65 mm
- \*\*CL6-1 = 13.95 mm
- \*\*CL6-2 = 14.10 mm

Form CL 6

Form	a mm	b mm	B mm	l mm	Part no.
CL 6	3.6	1.2	0.8	407	8906
CL 6-1	3.6	1.2	1.0	407	8906-1
CL 6-2	3.6	1.2	1.5	407	8906-2

Surface Finish and Plating Codes: see page 16

### CLIP-ON GASKETS

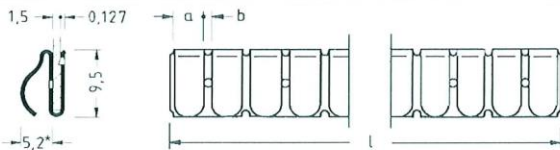

Form CL 7

\* CL7-1 = 6.9 mm  
also available with D + T-Lances  
\* CL7-2 = 7.9 mm

Form	a mm	b mm	l mm	Part no.
CL 7	5.32	1.04	406	8907
CL 7-1	5.32	1.04	406	8907-1
CL 7-2	5.32	1.04	406	8907-2

Surface Finish and Plating Codes: see page 16

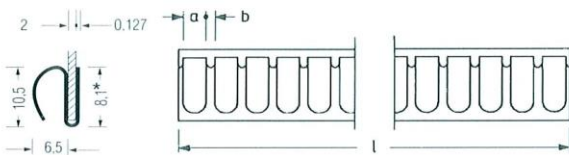

Form CL 8

\* CL8-2 = 7.4 mm / Clip = 3 mm

Form	a mm	b mm	l mm	Part no.
CL 8	3.2	1.55	405	8908*
CL 8-1	8.0	1.55	405	8908-1*
CL 8-2	3.2	1.55	405	8908-2*

Surface Finish and Plating Codes: see page 16

\* only available in CuBe

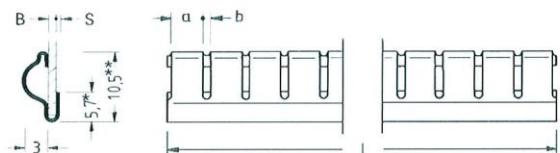

Form CL 9

\*CL9-1 = 5.50 mm  
\*CL9-2 = 5.25 mm  
\*CL9-3 = 5.20 mm  
\*\*CL9-1 = 10.5 mm  
\*\*CL9-2 = 10.5 mm  
\*\*CL9-3 = 10.0 mm

Form	a mm	b mm	B mm	l mm	S mm	Part no.
CL 9	5.7	0.6	0.8	409	0.05	8909*
CL 9-1	5.7	0.6	1.0	409	0.05	8909-1*
CL 9-2	5.7	0.6	1.5	409	0.05	8909-2*
CL 9-3	5.7	0.6	2.0	409	0.05	8909-3*

Surface Finish and Plating Codes: see page 16

\* only available in CuBe

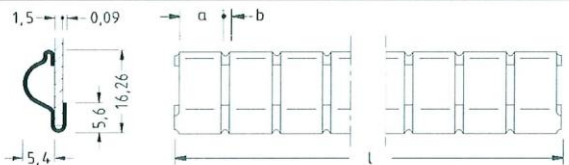

Form CL 10

Form	a mm	b mm	l mm	Part no.
CL 10	8.7	0.8	455	8910

Surface Finish and Plating Codes: see page 16

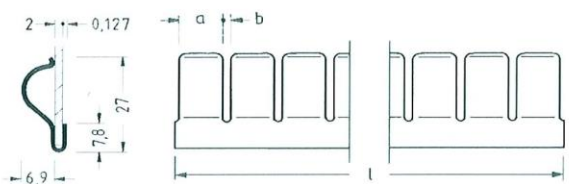

Form CL 11

Form	a mm	b mm	l mm	Part no.
CL 11	8.5	1.0	494	8911*

Surface Finish and Plating Codes: see page 16

\* only available in CuBe

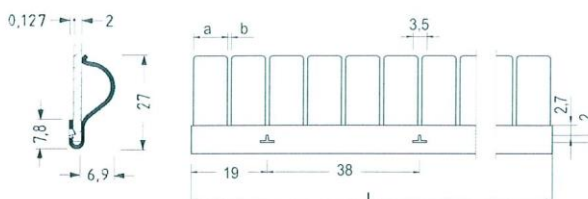

Form CL 12

With T-Lance attachment as shown

Form	a mm	b mm	l mm	Part no.
CL 12	8.5	1.0	494	8912*

Surface Finish and Plating Codes: see page 16

\* only available in CuBe



### CLIP-ON GASKETS

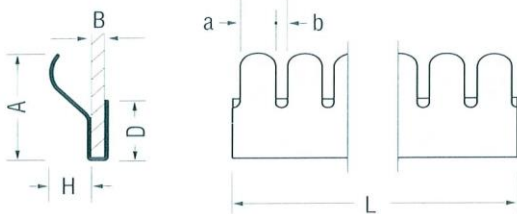

Material thickness 0.1 mm

Form CL 13 – CL 18

Form	a mm	b mm	A mm	B mm	D mm	H mm	L mm	Part no.
CL 13	3.56	1.22	15.2	1.0	7.4	5.3	406	8630
CL 14	3.56	1.22	15.2	1.5	6.9	5.3	406	8631
CL 15	3.56	1.22	15.2	2.0	6.4	5.3	406	8632
CL 16	3.6	1.2	8.3	1.0	6.3	2.5	407	8633
CL 17	3.6	1.2	8.3	1.5	5.8	2.5	407	8634
CL 18	3.6	1.2	8.3	2.0	5.4	2.5	407	8635

Surface Finish and Plating Codes: see page 16  
Also available with T-Lances

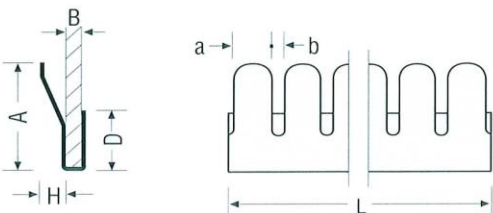

Material thickness 0.1 mm

Form CL 19 – CL 21

Form	a mm	b mm	A mm	B mm	D mm	H mm	L mm	Part no.
CL 19	3.6	1.2	11.4	1.0	6.9	2.5	407	8636
CL 20	3.6	1.2	11.4	1.5	6.4	2.5	407	8637
CL 21	3.6	1.2	11.4	2.0	5.8	2.5	407	8638

Surface Finish and Plating Codes: see page 16  
Also available with T-Lances

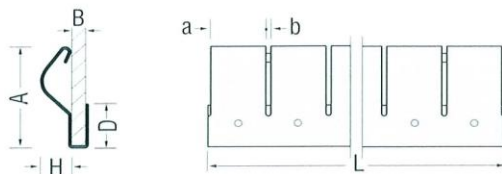

Material thickness 0.07 mm

Form CL 22 – CL 28

Form	a mm	b mm	A mm	B mm	D mm	H mm	L mm	Part no.
CL 22	5.85	0.5	11.7	1.0	6.1	3.0	457	8639*
CL 23	5.85	0.5	11.7	1.5	5.6	3.0	457	8640*
CL 24	5.85	0.5	11.7	2.0	5.1	3.0	457	8641*
CL 25	9.0	0.5	19.3	1.0	7.4	6.4	456	8642*
CL 26	9.0	0.5	19.3	1.5	6.9	6.4	456	8643*
CL 27	9.0	0.5	19.3	2.0	6.4	6.4	456	8644*
CL 28	9.0	0.5	19.3	3.0	5.3	6.4	456	8645*

Surface Finish and Plating Codes: see page 16  
Also available with T-Lances

\* only available in CuBe

### CLIP-ON GASKETS

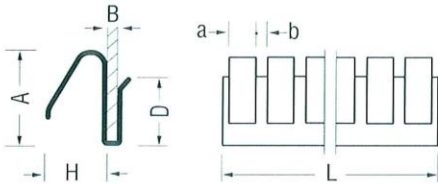

Material thickness  
 CL 32 – CL 35 : 0.15 mm  
 CL 36 – CL 37 : 0.08 mm

Form CL 29 – CL 37

Form	a mm	b mm	A mm	B mm	D mm	H mm	L mm	Part no.
CL 32*	3.2	1.55	12.25	1.0	8.25	7.2	407	8649
CL 33*	3.2	1.55	12.25	1.5	7.55	7.2	407	8650
CL 34*	3.2	1.55	12.25	2.0	7.55	7.2	407	8651
CL 35*	3.2	1.55	12.25	3.0	6.3	7.2	407	8652
CL 36	2.8	0.4	4.6	1.0	3.8	2.3	307	8653
CL 37	2.8	0.4	4.6	1.5	3.4	2.3	307	8654

Surface Finish and Plating Codes: see page 16

\* Also available with D-Lances

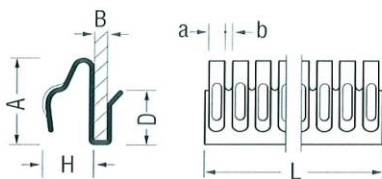

Material thickness  
 CL 38 – CL 41 : 0.15 mm  
 CL 42 – CL 44 : 0.13 mm  
 CL 45 – CL 46 : 0.08 mm

Form CL 38 – CL 46

Form	a mm	b mm	A mm	B mm	D mm	H mm	L mm	Part no.
CL 38	1.58	0.81	9.4	1.0	6.9	5.1	408	8655*
CL 39	1.58	0.81	9.4	1.5	6.4	5.1	408	8656*
CL 40	1.58	0.81	9.4	2.0	5.6	5.1	408	8657*
CL 41	1.5	0.5	9.4	3.0	4.6	5.1	408	8658*
CL 42	1.27	0.64	9.1	1.0	6.9	4.1	408	8659*
CL 43	1.27	0.64	9.1	1.5	6.9	4.1	408	8660*
CL 44	1.27	0.64	9.1	2.0	5.6	4.1	408	8661*
CL 45	1.09	0.51	6.1	1.0	5.3	2.8	406	8662*
CL 46	1.09	0.51	6.1	1.5	4.8	2.8	406	8663*

Surface Finish and Plating Codes: see page 16

\* only available in CuBe

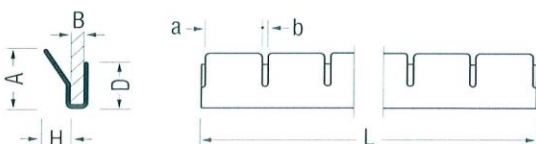

Material thickness 0.08 mm

Form CL 47 – CL 49

Form	a mm	b mm	A mm	B mm	D mm	H mm	L mm	Part no.
CL 47	3.8	0.4	4.8	0.8	3.0	1.3	306	8664
CL 48	3.8	0.4	4.8	1.0	2.8	1.3	306	8665
CL 49	3.8	0.4	4.8	1.5	2.3	1.3	306	8666

Surface Finish and Plating Codes: see page 16

Also available with D-Lances

### CURVED FINGERS

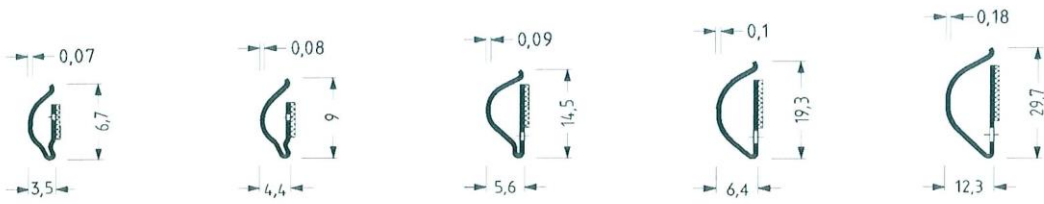
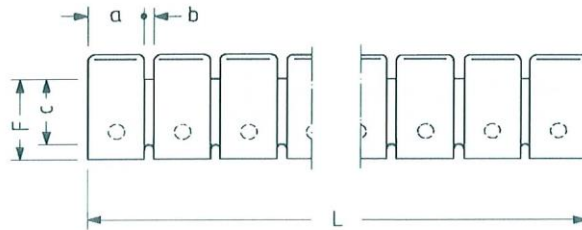

All contact strips are provided with two-sided adhesive strip.

Form	V10	V11	V12	V13	V14	
Form	a mm	b mm	c mm	F mm	L mm	Part no.
V10	4.32	0.46	3.85	5.5	406	9001*
					7620	9002
V11	5.79	0.56	3.85	7.5	406	9003*
					7620	9004
V12	8.71	0.81	10.00	12.60	609	9005
					7620	9006
V13	8.51	1.02	10.00	12.00	608	9007*
					7620	9008
V14	11.68	1.02	17.00	17.80	304	9009*

\* only available in CuBe

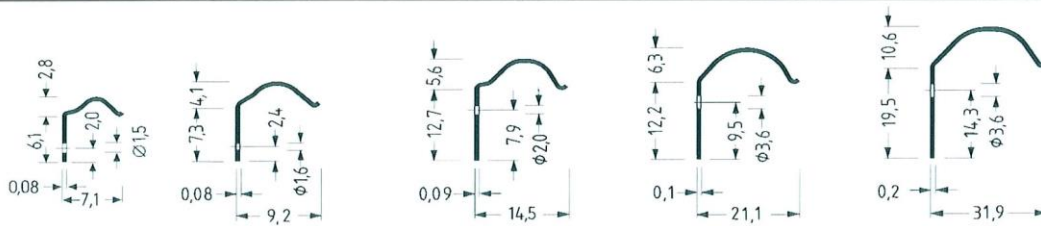

Form	V15-1	V15	V16	V17	V18	
Form	a mm	b mm	c mm	F mm	L mm	Part no.
V15-1	4.32	0.46	3.7	5.5	406	9019*
V15	5.79	0.56	3.9	7.6	406	9020*
V16	8.71	0.81	9.9	12.9	609	9021*
V17	8.51	1.02	11.8	12.7	304	9022*
V18	11.68	1.02	18.0	19.9	304	9023*

\* only available in CuBe

## SLIPPY FINGERS

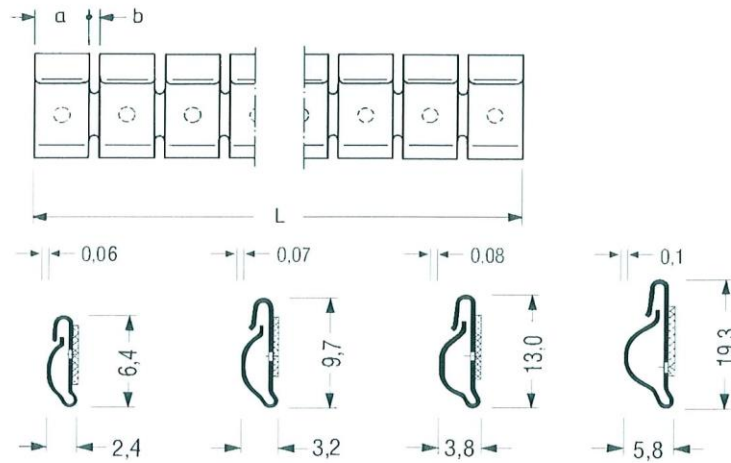

All contact strips are provided with two-sided adhesive strip.

Form

V19

V20

V21

V22

Form	a mm	b mm	∅ mm	L mm	Part no.
V19	4.32	0.46	1.5	406	9030*
				7620	9031*
V20	4.32	0.46	1.5	406	9032*
				7620	9033*
V21	5.79	0.56	1.5	406	9034*
				7620	9035*
V22	8.71	0.81	1.5	608	9036*
				7620	9037*

\* only available in CuBe

# GROUNDING AND SHIELD STRIPS

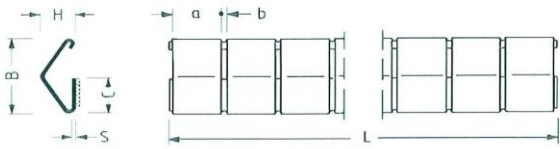

Form W1-W5

Surface Finish and Plating Codes: see page 16

All contact strips are provided with two-sided adhesive strip.

Form	a mm	b mm	C mm	H mm	B mm	S mm	L mm	Part no.
W1	4.3	0.5	5.3	2.8	8.8	0.05	408	9040
W2	5.7	0.6	5.3	3.3	9.4	0.05	409	9041
W3	8.7	0.8	7.2	5.7	15.2	0.08/0.05	608	9042
W4	8.7	0.1	11.2	8.1	19.8	0.10	455	9043
W5	11.7	1.0	19.8	10.4	27.9	0.10	455	9044

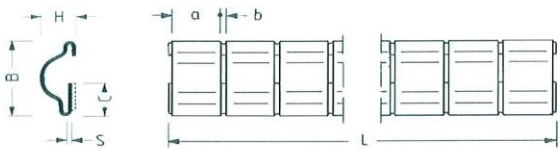

Form W6-W9

Surface Finish and Plating Codes: see page 16

All contact strips are provided with two-sided adhesive strip.

Form	a mm	b mm	C mm	H mm	B mm	S mm	L mm	Part no.
W6	4.3	0.5	5.4	2.5	8.1	0.09	408	9045*
W7	5.7	0.6	5.25	3.3	9.4	0.09	406	9046*
W8	3.9	0.8	7.4	5.6	15.2	0.09	455	9047*
W9	8.7	0.8	7.4	5.6	15.2	0.09	456	9048*
W10	5.7	0.6	5.45	5.15	8.4	0.05	409	9049

\* only available in CuBe

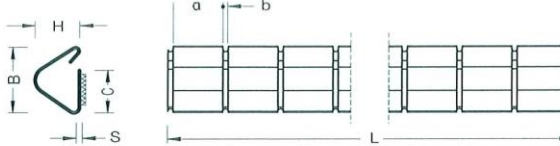

Form W10

Surface Finish and Plating Codes: see page 16

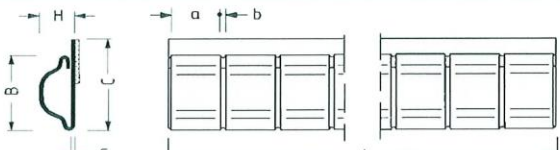

Form W12

Surface Finish and Plating Codes: see page 16

Form	a mm	b mm	C mm	H mm	B mm	S mm	L mm	Part no.
W12	8.72	0.8	19.8	5.6	15.2	0.09	456	9051

All contact strips are provided with two-sided adhesive strip.

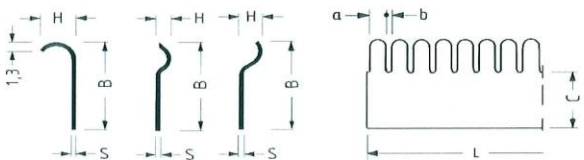

Form J1

J2

J3

Surface Finish and Plating Codes: see page 16

Form	a mm	b mm	C mm	H mm	B mm	S mm	L mm	Part no.
J1	3.56	1.22	16.0	5.8	19.6	0.13	407	9060*
J2	3.56	1.22	16.0	2.3	22.6	0.13	407	9061*
J3	3.56	1.22	16.0	3.3	22.6	0.13	407	9062*

\* only available in CuBe

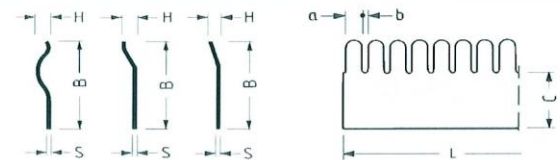

Form J4

J5

J6

Surface Finish and Plating Codes: see page 16

Form	a mm	b mm	C mm	H mm	B mm	S mm	L mm	Part no.
J4	3.56	1.22	16.0	2.3	23.4	0.13	406	9063*
J5	3.56	1.22	16.0	2.3	23.4	0.13	406	9064*
J6	3.56	1.22	16.0	2.3	23.4	0.13	406	9065*

\* only available in CuBe

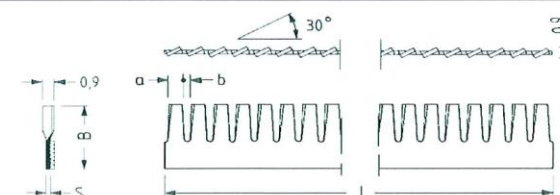

Form Z

Surface Finish and Plating Codes: see page 16

All contact strips are provided with two-sided adhesive strip.

Form	a mm	b mm	C mm	B mm	S mm	L mm	Part no.
Z	1.65	0.76	4.1	9.1	0.13	407	9070

L also to customer specifications.

# SLOT-MOUNT SHIELDS

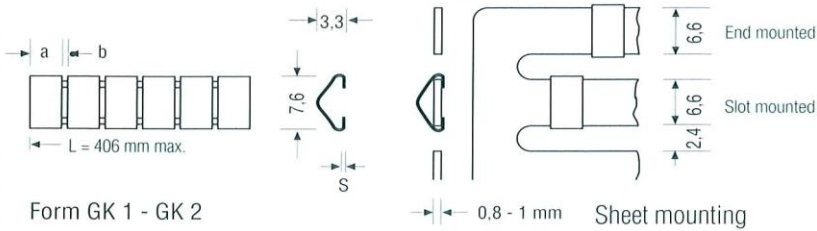

Form GK 1 - GK 2

Surface Finish and Plating Codes: see page 16

Form	a mm	b mm	S mm	Part no.
GK 1	4.3	0.5	0.05	9701
GK 2	4.3	0.5	0.09	9702

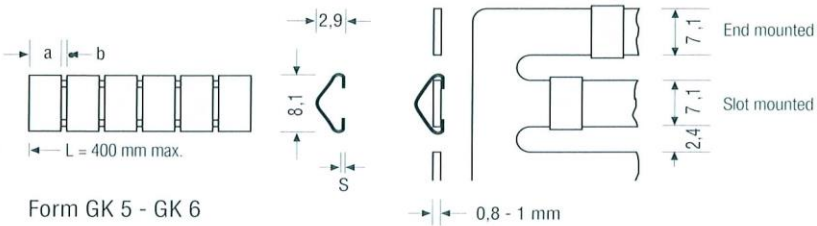

Form GK 5 - GK 6

Surface Finish and Plating Codes: see page 16

Form	a mm	b mm	S mm	Part no.
GK 5	4.3	0.5	0.05	9705
GK 6	4.3	0.5	0.09	9706

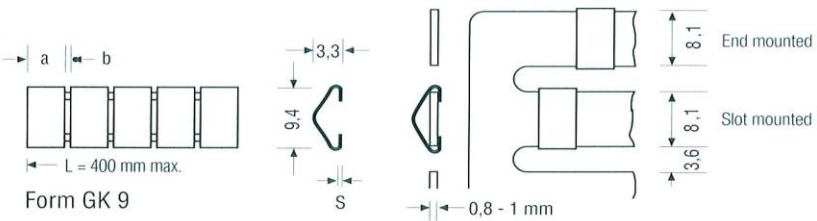

Form GK 9

Surface Finish and Plating Codes: see page 16

Form	a mm	b mm	S mm	Part no.
GK 9	5.7	0.6	0.05	9709

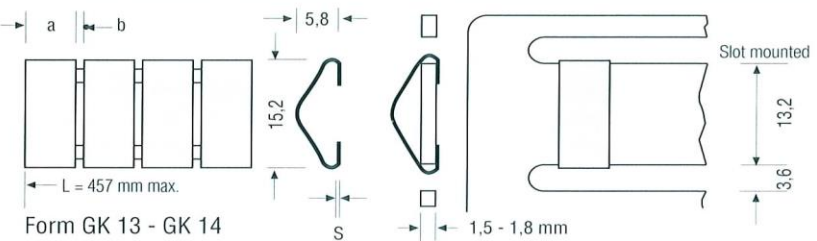

Form GK 13 - GK 14

Surface Finish and Plating Codes: see page 16

Form	a mm	b mm	S mm	Part no.
GK 13	6.4	0.8	0.08	9713
GK 14	6.4	0.127	0.13	9714

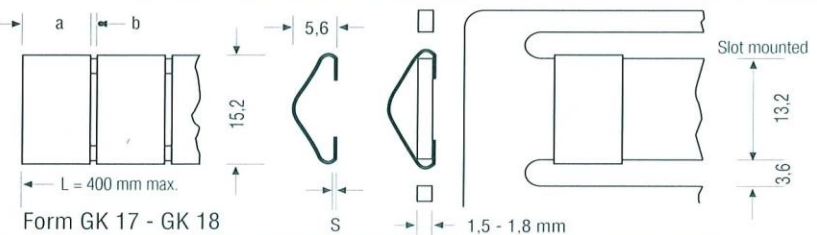

Form GK 17 - GK 18

Surface Finish and Plating Codes: see page 16

Form	a mm	b mm	S mm	Part no.
GK 17	8.7	0.8	0.05	9717
GK 18	8.7	0.8	0.10	9718

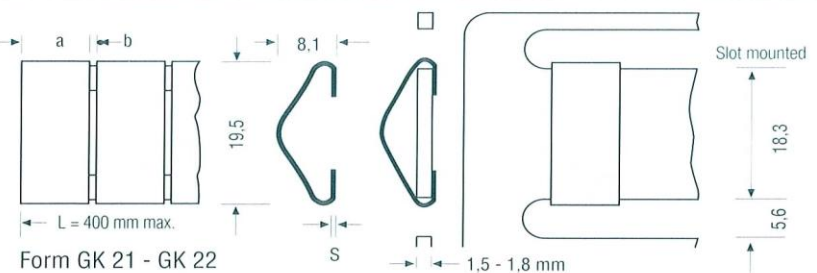

Form GK 21 - GK 22

Surface Finish and Plating Codes: see page 16

Form	a mm	b mm	S mm	Part no.
GK 21	8.7	0.8	0.08	9721
GK 22	8.7	0.8	0.10	9722

# TRACKS AND ACCESSORIES

### Mounting on riveted track

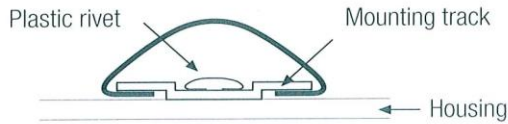

Instead of slots in the housing, a mounting track can be used for the shields with a T-end-piece.

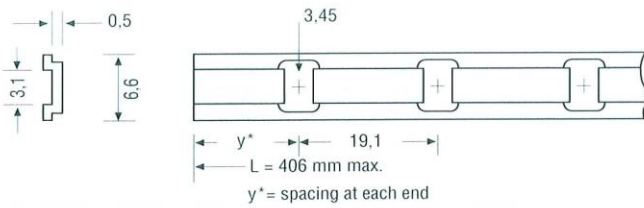

Mounting track	Part no.
MS 2 for GK 5 - 6	9730

Material: Stainless steel

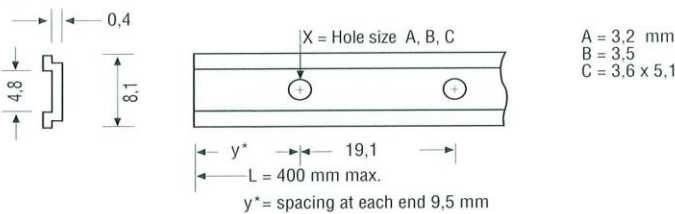

Mounting track	Part no.
MS 3 for GK 9	9735

Material: Brass

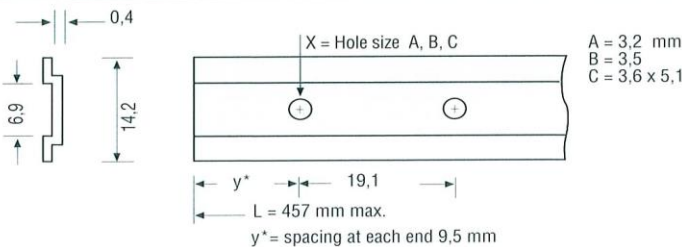

Mounting track	Part no.
MS 4 for GK 13 - 18	9740

Material: Brass

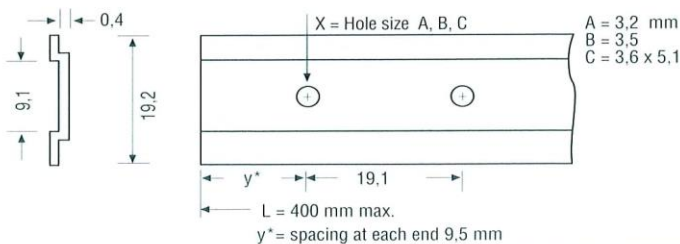

Mounting track	Part no.
MS 5 for GK 21 - 22	9745

Material: Brass

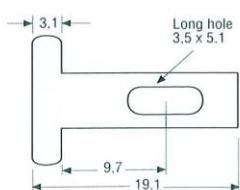

TE 1 - 3

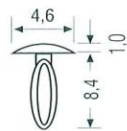

Drilling  
∅ 3,1 - 3,2

NE 1



Drilling  
∅ 3,0 - 3,1

NE 2

T-end-piece	Part no.
TE 1 for GK 9	9750
TE 2 for GK 13 - 18	9751
TE 3 for GK 21 - 22	9752
Plastic rivet	
NE 1 for sheet 0.5 - 1.5 mm	9754
NE 2 for sheet 1.1 - 1.9 mm	9755

### ROUNDED SHIELDS

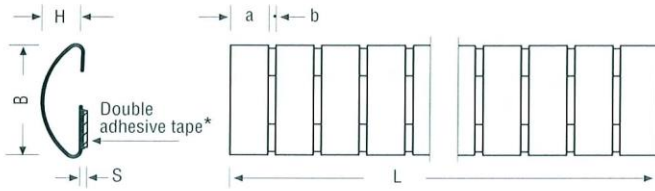

Form HR 1 - 3 \*HR 1 = 4,1 HR 2 = 6,5 HR 3 = 7  
HR 1 - HR 3 not equal-sided

Form	a mm	b mm	H mm	B mm	S mm	L mm	Part no.
HR 1	4.3	0.5	2.8	9.1	0.08	403	9760
HR 2	5.8	0.6	3.6	11.4	0.08	383	9761*
HR 3	8.8	0.8	5.6	15.8	0.10	379	9762*

Surface Finish and Plating Codes: see page 16  
\* only available in CuBe

The shields can also be mounted on riveted track. Ideal for bi-directional load.

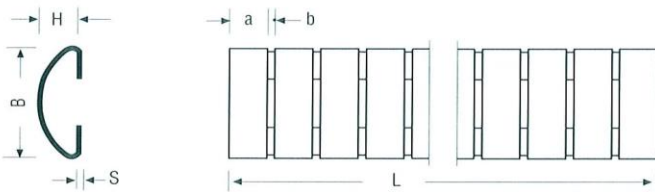

Mounting track for HR 6 - 8

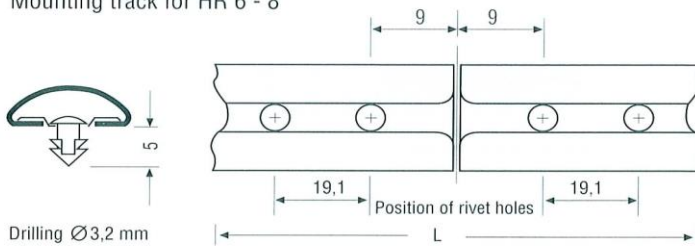

Form	B mm	H mm	No. of rivets	Part no.
HR 6	9.1	2.8	10	9763
HR 7	11.4	3.6	10	9764*
HR 8	15.8	5.6	10	9765*

Surface Finish and Plating Codes: see page 16  
\* only available in CuBe

Form	A mm	L mm	Part no.
MS 6	8.1	400	9763
MS 7	11.0	381	9764
MS 8	15.2	381	9765

Material: Brass or stainless steel

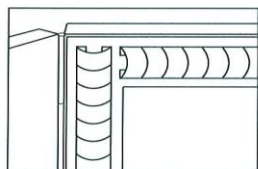

HR 1 - HR 3

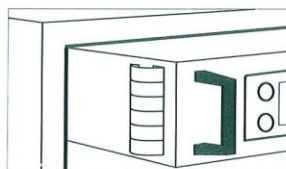

HR 6 - HR 8

Examples of typical application

#### Surface finishes for all shields

You can choose from a wide range of standard surface finishes. Just add the code as a suffix to the part number while ordering. For example BC 9760-17 means a shield form HR1 with tin plating. Other special finishes are available upon request.

Code	Surface finish
- 02	bright finish
- 03	gold plating
- 04	silver plating
- 15	zinc chromate
- 17	bright tin
- 19	bright nickel
- 00	custom



# PCB CONTACT FINGERS

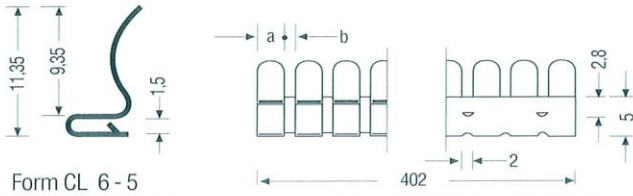

Form CL 6 - 5

Form	a mm	b mm	Part no.
CL 6 - 5	3.6	1.2	8906 - 5

Material thickness: 0.127 mm  
Surface Finish and Plating Codes: see page 16

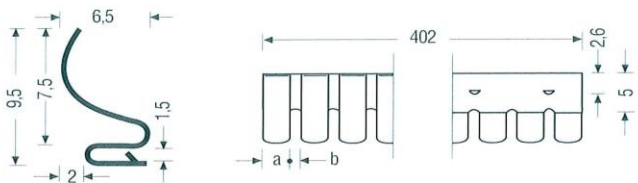

Form CL 6 - 6

Form	a mm	b mm	Part no.
CL 6 - 6	3.6	1.2	8906 - 6

Material thickness: 0.127 mm  
Surface Finish and Plating Codes: see page 16

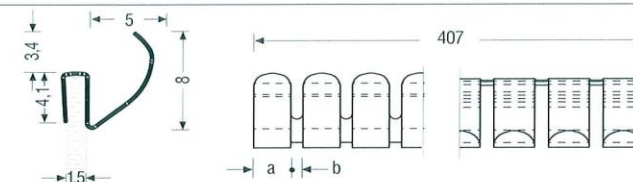

Form CL 6 - 7

Form	a mm	b mm	Part no.
CL 6 - 7	3.6	1.2	8906 - 7

Material thickness: 0.127 mm  
Surface Finish and Plating Codes: see page 16

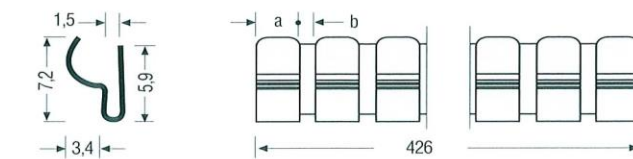

Form CL 3 - 2

Form	a mm	b mm	Part no.
CL 3 - 2	3.6	1.2	8903 - 2

Material thickness: 0.127 mm  
Surface Finish and Plating Codes: see page 16

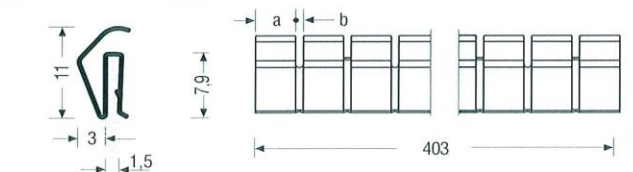

Form CL 57

Form	a mm	b mm	Part no.
CL 57	5.31	1.0	8669

Material thickness: 0.08 mm  
Surface Finish and Plating Codes: see page 16

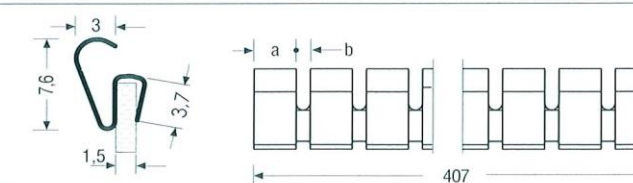

Form CL 58

Form	a mm	b mm	Part no.
CL 58	3.6	1.2	8918

Material thickness: 0.08 mm  
Surface Finish and Plating Codes: see page 16

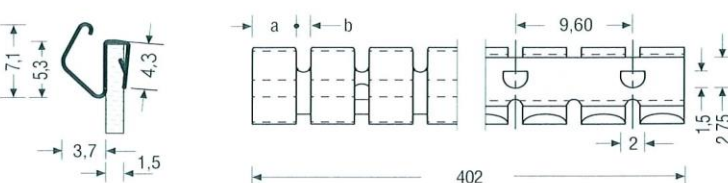

Form CL 59

Form	a mm	b mm	Part no.
CL 59	3.6	1.2	8917

Material thickness: 0.08 mm  
Surface Finish and Plating Codes: see page 16

### PCB CONTACT FINGERS

<p>Form CL 60 M</p>	<p>Surface Finish and Plating Codes: see page 16</p>	Form	a mm	b mm	Part no.
		CL 60 M	3.6	1.2	8913-M
Material thickness: 0.08 mm					
<p>Form CL 60</p>	<p>Surface Finish and Plating Codes: see page 16</p>	Form	a mm	b mm	Part no.
		CL 60	9.0	0.8	8913
Material thickness: 0.08 mm					
<p>Form CL 61</p>	<p>Surface Finish and Plating Codes: see page 16</p>	Form	a mm	b mm	Part no.
		CL 61	5.6	0.8	8914*
Material thickness: 0.127 / 0.08 mm * only available in CuBe					
<p>Form CL 62</p>	<p>Surface Finish and Plating Codes: see page 16</p>	Form	a mm	b mm	Part no.
		CL 62	12.68	1.14	8915*
Material thickness: 0.07 mm * only available in CuBe					
<p>Form CL 63</p>	<p>Surface Finish and Plating Codes: see page 16</p>	Form	a mm	b mm	Part no.
		CL 63	3.0	1.0	8916*
<p>Form CL 63-1 = Clip 1.5</p>	<p>Surface Finish and Plating Codes: see page 16</p>	Form	a mm	b mm	Part no.
		CL 63-1	3.0	1.0	8916-1*
Material thickness: 0.09 mm * only available in CuBe					

### Low profile gaskets

<p>Form NP</p>	Form	a mm	b mm	C mm	H mm	B mm	S mm	L mm	Part no.									
	NP2	2.5	0.6	6.0	2.0	11.4	0.05	406	2001									
with double adhesive transfer tape																		
<table border="1"> <tbody> <tr> <td>NP3</td> <td>2.5</td> <td>0.6</td> <td>8.2</td> <td>3.0</td> <td>15.2</td> <td>0.05</td> <td>406</td> <td>2002</td> </tr> </tbody> </table>										NP3	2.5	0.6	8.2	3.0	15.2	0.05	406	2002
NP3	2.5	0.6	8.2	3.0	15.2	0.05	406	2002										

### Low profile gaskets, hook-on type

<p>Form NPH</p>	Form	a mm	b mm	C mm	H mm	B mm	S mm	L mm	Part no.									
	NPH	2.5	0.6	6.0	1.5	11.4	0.05	406	2003									
with double adhesive transfer tape																		
<table border="1"> <tbody> <tr> <td>NPH</td> <td>2.5</td> <td>0.6</td> <td>8.2</td> <td>2.3</td> <td>15.2</td> <td>0.05</td> <td>406</td> <td>2004</td> </tr> </tbody> </table>										NPH	2.5	0.6	8.2	2.3	15.2	0.05	406	2004
NPH	2.5	0.6	8.2	2.3	15.2	0.05	406	2004										

### PCB CONTACT FINGERS

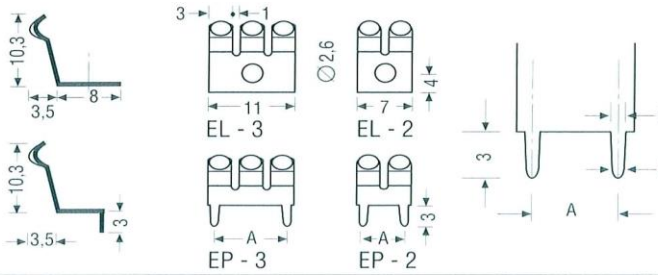

Surface Finish and Plating Codes: see page 16

Form	No. of fingers	A mm	Part no.
EL - 3	3	-	8920
EL - 2	2	-	8921
EP - 3	3	10	8925
EP - 2	2	5	8926

Material thickness: 0.2 mm

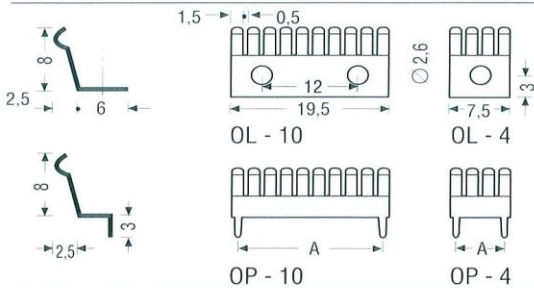

Surface Finish and Plating Codes: see page 16

Form	No. of fingers	A mm	Part no.
OL	10	-	8930
	4	-	8931
OP	10	17.5	8935
	4	5	8936

Material thickness: 0.15 mm

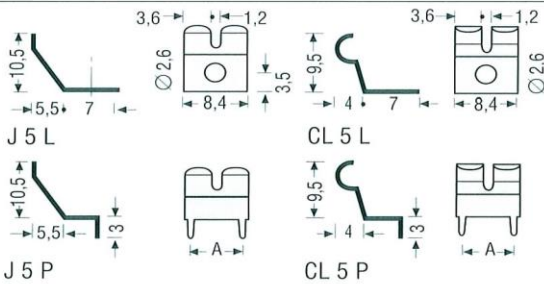

Surface Finish and Plating Codes: see page 16

Form	No. of fingers	A mm	Part no.
J 5 L	2	-	8940
J 5 P	2	5	8941
CL 5 L	2	-	8945
CL 5 P	2	5	8946

Material thickness: 0.127 mm

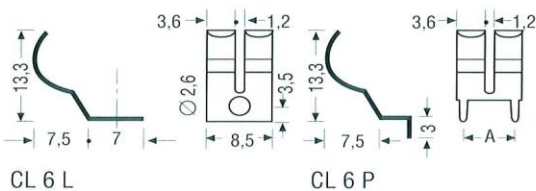

Surface Finish and Plating Codes: see page 16

Form	No. of fingers	A mm	Part no.
CL 6 L	2	-	8950
CL 6 P	2	5	8955

Material thickness: 0.127 mm

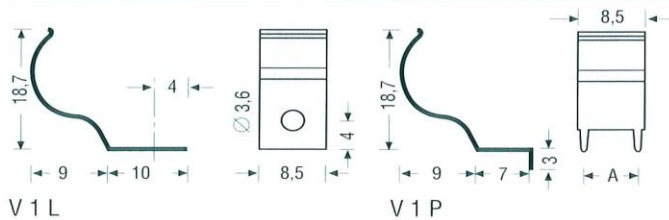

Surface Finish and Plating Codes: see page 16

Form	No. of fingers	A mm	Part no.
V 1 L	1	-	8960 *
V 1 P	1	5	8965 *

Material thickness: 0.127 mm \* only available in CuBe

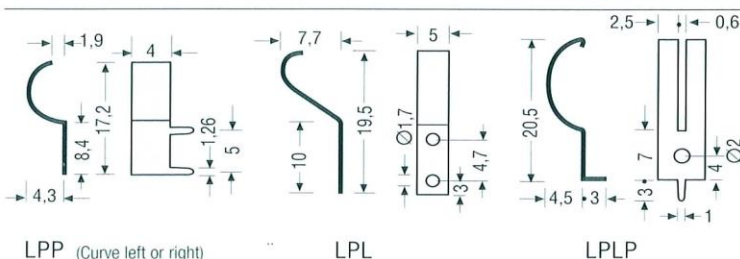

Form	No. of fingers	A mm	Part no.
L P P	1	-	8970 *
L P L	1	-	8980
L P L P	2	-	8990

Material thickness: LPP=0.15 LPL=0.15 LPLP=0.15 mm \* please state r (right) or l (left) for ordering

# CONTACT STRIPS AND RINGS

For tube 2 C 39 BA

Anode Contact Ring

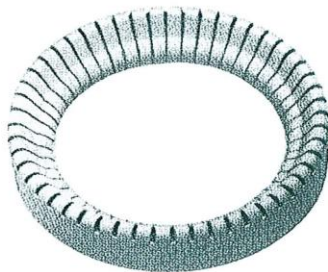

Form Q  
Ø 33 mm\*

Grid Contact Ring

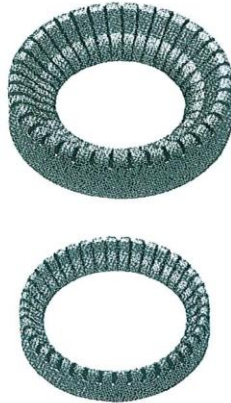

Form Q  
Ø 23.5 mm\*

Form S  
Ø 19.5 mm\*

Cathode Contact Ring



Form R  
Ø 9.25 mm\*

Form S  
Ø 12.6 mm\*

Heating Contact

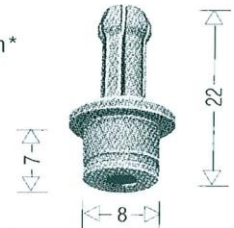

\*Outer diameters

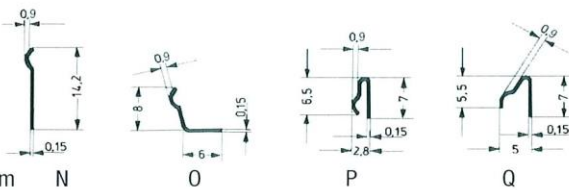
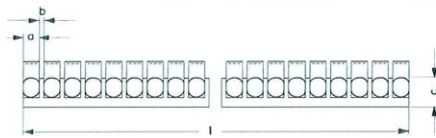

Form

N

O

P

Q

Form	a mm	b mm	c mm	l mm	Part no.
N	1.5	0.5	5.5	500	8113
O	1.5	0.5	5.5	500	8114
P	1.5	0.5	5.5	500	8115
Q	1.5	0.5	5.5	500	8116

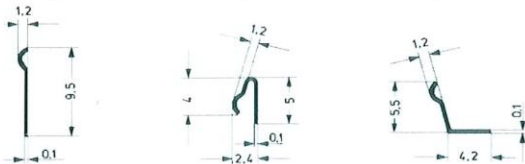

Form

R

S

T

Form	a mm	b mm	c mm	l mm	Part no.
R	1.0	0.5	3.2	500	8117
S	1.0	0.5	3.2	500	8118
T	1.0	0.5	3.2	500	8119

### Material options

*Material:* hardened (available from stock) or unhardened

*Finish:* bright finish or silver plated

### Special options

*Component:* as a single finger, contact strip (available from stock) or contact ring

*Note:* almost all strips could be formed into a ring by user

### DIN Connector gaskets

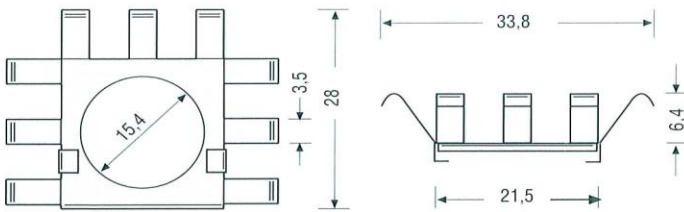
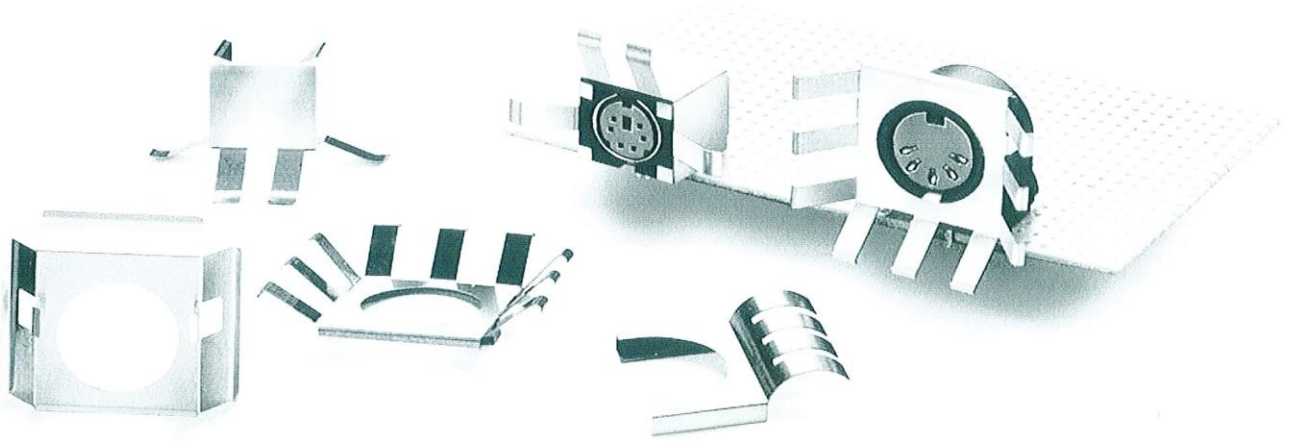

Part no.
9540

Material: CuBe 2  
 Material thickness: 0.2 mm  
 Surface Finish and Plating Codes: see page 16

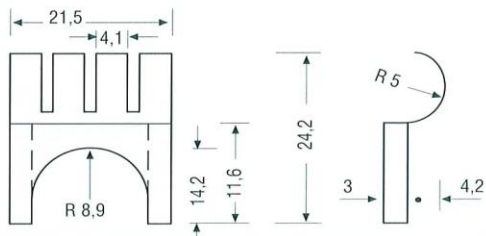

Part no.
9550

Material: CuBe 2  
 Material thickness: 0.2 mm  
 Surface Finish and Plating Codes: see page 16

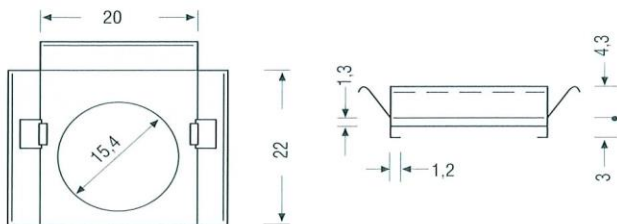

Part no.
9560

Material: CuBe 2  
 Material thickness: 0.2 mm  
 Surface Finish and Plating Codes: see page 16

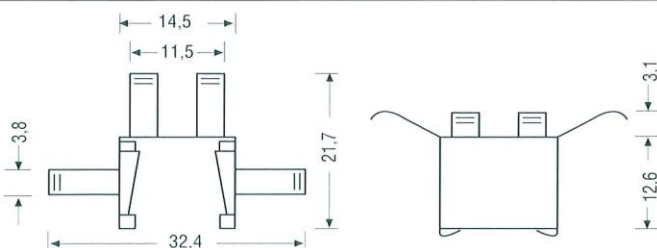

Part no.
9570

Material: CuBe 2  
 Material thickness: 0.12 mm  
 Surface Finish and Plating Codes: see page 16

## SHIELDED CASES AND CABINETS

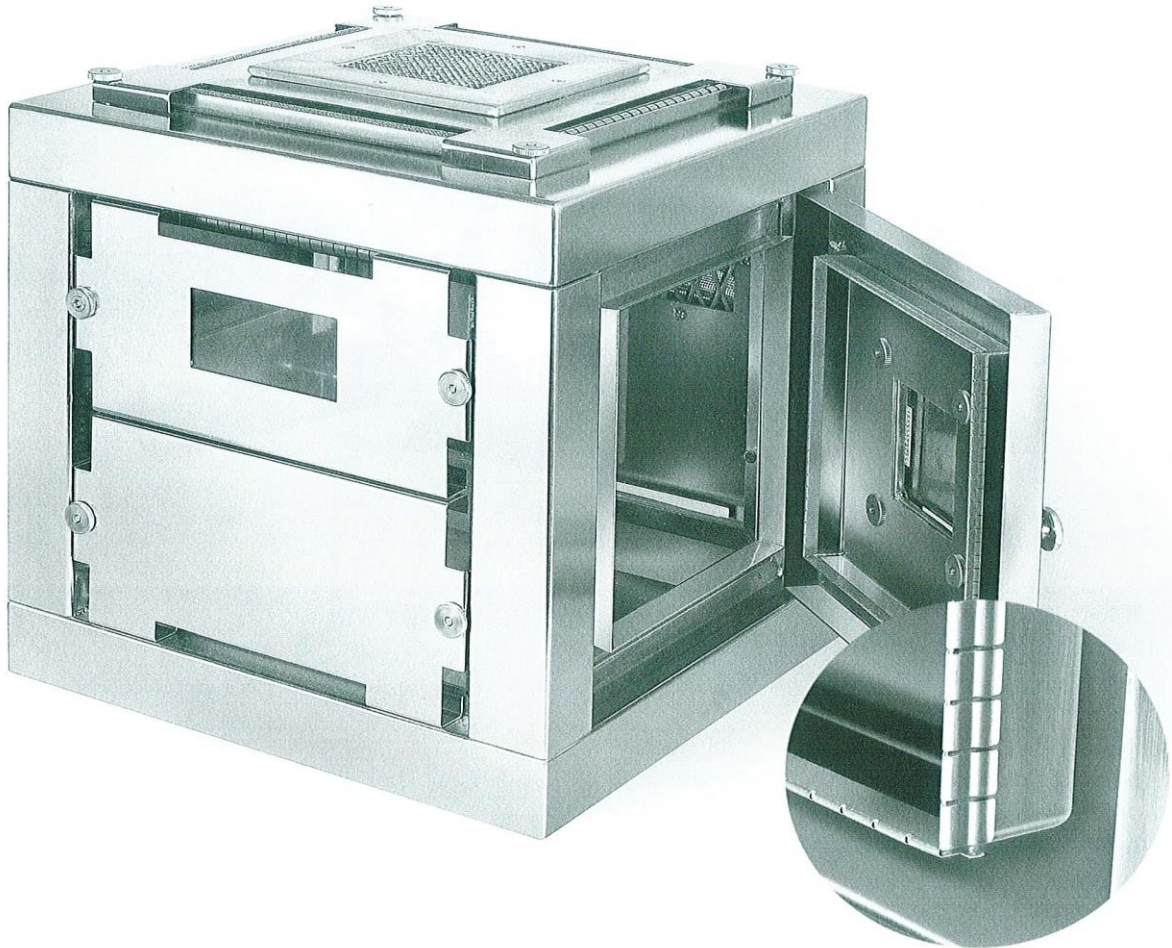

---

### Description

These products are realized and supplied according to customer specification and drawing

*Standard materials:* carbon steel, stainless steel and aluminium

*Shielding and grounding:* fingers or other emc gaskets available as standard

*Options:*

- ventilation openings with shielding panel(or air filter)
- inspection window with emc optical filter

### PCB SCREENS



Tin plated steel (0.6 mm)  
Pin size: 2.5 x 1 mm

L (length) mm	B (width) mm	H (height) mm	Part no.
25	25	15	9501
30	25	18	9502
40	28	20	9503
40	32	18	9504
60	40	20	9505
70	50	25	9506

Can with pins for PCB mounting

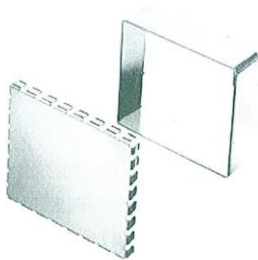

Tin plated steel (0.9mm)  
Pin size: 2.3x1 mm

L (length) mm	B (width) mm	H (height) mm	Part no.
20	20	10	9510
30	30	15	9511
50	25	15	9512
50	50	15	9513
75	50	25	9514
75	75	25	9515
100	50	25	9516
125	75	25	9517

PCB mounting frame with fingered lid

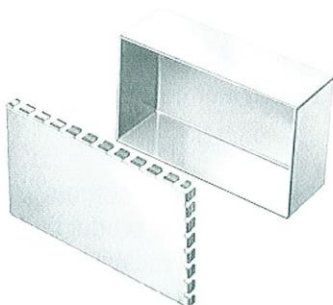

Tin plated steel (0.9mm)

L (length) mm	B (width) mm	H (height) mm	Part no.
50	50	15	9520
75	50	25	9521
100	50	35	9522
160	100	50	9523

Standard can with fingered lid

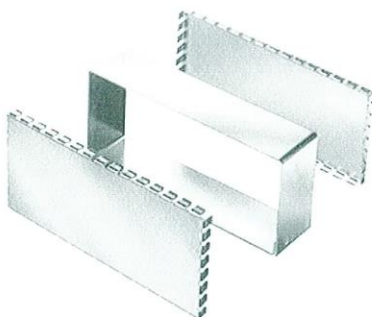

Tin plated steel (0.9mm)

L (length) mm	B (width) mm	H (height) mm	Part no.
50	50	15	9530
75	50	15	9531
100	50	25	9532
160	100	35	9533
220	100	50	9534

Open frame with top and bottom fingered lids

### Conductive elastomer



The conductive elastomer are made by metal powder and silicon. It has excellent EMI shielding effectiveness and environment sealing and long life time. The conductive fillers are nickel graphite, silver glass, silver aluminum, silver copper.

We have standard size and shapes, we could also extruded, molded and die-cut any shapes or size as the customer design and requirements.

### Specifications

Conductive Particles	Carbon	Nickel Graphite	Silver Glass	Silver Nickel	Silver Aluminum	Silver Copper	Silver Low Density
MIL-G-83528 Type	N/A	N/A	M	L	B, D	A, C, K	J
Operating Temperature							
Min (°C)	-55	-55	-55	-55	-55	-55	-55
Max (°C)	175	200	200	180	200	125	160
Specific Gravity	1.2	1.95	1.8	4	2	3.5	1.7
Hardness (Shore A) Durometer	70	70	65	75	65	65/75/85	45
Compression Deflection (% min)	3.5	3.5	3.5	3.5	3.5	3.5	8
Tensile Strength (lbs/sq-in)	450	150	200	200	200	200	150
Elongation (%)	3.5	3.5	3.5	3.5	3.5	3.5	8
Volume Resistivity (ohm-cm)	8	0.1	0.005	0.005	0.008	0.004	0.001
Shielding Effectiveness (20mhz-10ghz)	40	80	110	100	110	110	80
EMP survivability	yes	yes	yes	yes	yes	yes	yes

AC = Silver Copper  
NG = Nickle Graphite



Flat sheet Unit: mm

THICKNESS	Tolerance	Width×Length			
		254×254	254×381	381×508	457×457
0.51	±0.10				
0.81	±0.13				
1.02	±0.15				
1.57	±0.18				

Rectangular Strip Unit: mm

Part No.	Size		Part No.	Size	
	A	B		A	B
4000-0100	1.60	1.07	4000-0120	3.96	1.57
4000-0105	2.41	1.57	4000-0125	6.35	1.57
4000-0110	3.05	1.91	4000-0130	12.70	1.91
4000-0115	3.18	1.57	4000-0135	12.70	3.18

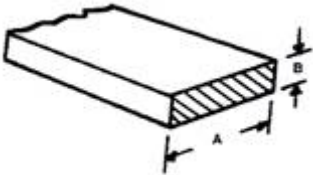

Hollow rectangular tube Unit: mm

Part No.	size		
	A	B	C
4100-0100	8.38	7.75	3.18
4100-0105	9.53	9.53	4.78

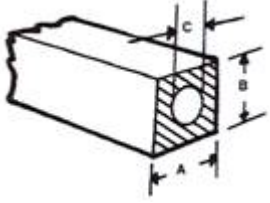

Round shape strip Unit: mm

Part No.	A	Recommend notch size		Part No.	A	Recommend notch size	
		W	H			W	H
4200-0100	1.02	1.27	0.76	4200-0130	2.62	3.00	1.88
4200-0105	1.35	1.57	1.02	4200-0135	2.84	3.07	2.34
4200-0110	1.57	1.78	1.19	4200-0140	3.02	3.30	2.29
4200-0115	1.78	2.11	1.27	4200-0145	3.18	3.53	2.36
4200-0120	2.03	2.29	1.52	4200-0150	3.30	3.50	2.72
4200-0125	2.36	2.62	1.78	4200-0160	3.53	3.99	2.56
4200-0175	5.49	6.12	4.06	4200-0165	3.81	4.01	3.12
4200-0180	6.35	6.98	4.75	4200-0170	4.06	4.27	3.33

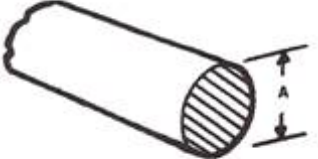

# EMI SHIELDING

# Patron

## Passive Elektronik

**Hollow round tube** Unit: mm

Part No.	Diametre		Notch size		Part No.	Diametre		Notch size	
	A	B	W	H		A	B	W	H
4300-0100	3.18	1.14	3.30	2.23	4300-0130	11.10	6.35	7.52	11.40
4300-0105	3.96	1.27	4.06	2.76	4300-0090	2.29	1.27	2.36	1.55
4300-0110	6.35	3.18	5.71	3.81	4300-0095	2.62	1.02	2.72	1.85
4300-0120	7.92	4.88	8.05	3.96	4300-0101	3.18	1.57	3.30	1.95
4300-0125	9.53	6.35	9.65	4.49	4300-0104	3.68	1.78	--	--

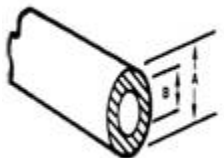

**D shape strip** Unit: mm

Part No.	Size			Recommend notch size	
	A	B	R(rad)	W	H
4400-0100	1.63	4.10	0.79	--	--
4400-0105	1.57	1.73	0.79	1.65	1.29
4400-0110	2.39	1.98	1.19	2.46	1.50
4400-0115	1.98	2.26	0.99	2.03	1.67
4400-0120	1.57	2.54	0.78	1.65	1.90
4400-0125	3.81	2.79	1.91	3.93	2.10
4400-0130	3.10	3.43	1.55	3.17	2.56
4400-0135	3.00	3.96	1.49	3.04	2.97
4400-0140	4.52	4.45	2.26	4.60	3.32
4400-0145	6.35	6.35	3.18	6.47	4.75

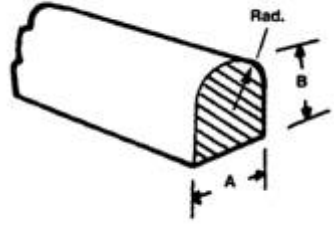

**Hollow D tube** Unit: mm

Part No.	Size				Notch Size	
	A	B	R(rad)	C	W	H
4500-0100	3.96	3.96	1.98	1.14	4.06	2.36
4500-0105	4.75	4.75	2.36	1.27	4.90	2.71
4500-0110	6.35	6.35	3.18	1.65	6.47	3.81
4500-0120	7.92	7.92	2.84	1.57	8.12	4.49
4500-0125	12.37	12.37	6.20	2.03	12.70	6.35



# EMI SHIELDING

# Patron

*Passive Elektronik*

**P shape strip** Unit: mm

Part No.	Size			
	B	C	A	D
4600-0100	5.08	2.03	21.59	1.57
4600-0101	5.08	2.03	12.07	1.57
4600-0105	6.35	3.18	12.70	1.57
4600-0110	6.35	3.18	15.88	1.57
4600-0120	6.35	3.81	15.88	1.57
4600-0125	7.92	4.75	22.22	1.57
4600-0130	9.14	6.48	19.81	1.79
4600-0136	3.56	2.54	6.99	0.76

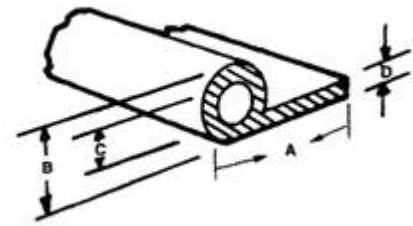

**U Shape strip** Unit: mm

Part No.	Size			
	A	B	C	D
4700-0100	2.54	2.54	0.86	0.84
4700-0105	3.20	2.79	0.64	1.27
4700-0110	3.20	5.72	0.51	1.91
4700-0115	3.96	3.96	1.57	1.19
4700-0120	4.45	3.96	1.19	1.91
4700-0125	8.31	5.97	1.57	1.57

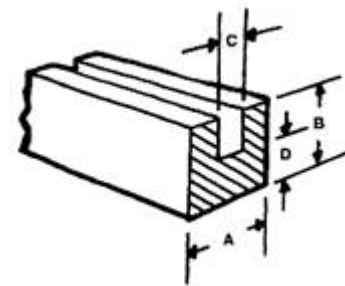

## ABS LPRFA-T

### Rubber Flat Narrowband Absorber

#### Characteristics

Applied frequency: 1-40GHz

Thickness: determined by the resonance frequency(application center frequency)

Heat resistance characteristics: -50°C-150°C

Environment applied: Can be applied to any bad environment

Power resistance: above 2kW.m-2

Absorbing performanc: resonance absorption attenuation ≤ -18dB

Applications: LPRFA-T is suitable to where need wafer and no need of broadband, it should have metal bottom and closely paste when use. It is mainly used for reflection of metal components in radome and liners of radar house, to suppress electromagnetic interference , etc.

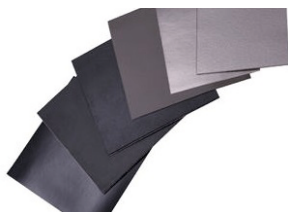

Model	Resonant frequency GHz	Thickness (mm)	Weight (Kg/m <sup>2</sup> )	Vertical incidence reflectivity - dB
Patron-ABS-LPRFA-T40	40	0,7	2	18
Patron-ABS-LPRFA-T15	15	1,3	3,5	18
Patron-ABS-LPRFA-T10	10	1,8	5,2	18
Patron-ABS-LPRFA-T7	7	2,5	7	18
Patron-ABS-LPRFA-T5	5	3	8	18
Patron-ABS-LPRFA-T2	2	6,8	17	18

## PU Faom Based Flat Absorber

## ABS LPPFA-T

#### Characteristics

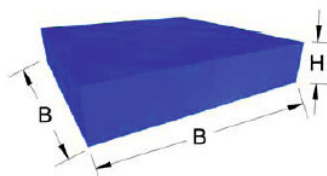

1) Such absorbers have a flat appearance, with black color (it can be selected as request), it is clean and soft.

2) Oxygen index ≥ 29% (GB/T2406-93), which belongs to flame retardant B2 level(GB8624-1997)

3) Good environmental performance, all raw materials can meet the environmental requirements, no volatile, no smell and non-toxic.

4) Installation method: Direct adhesive paste and the absorbers with self-adhesive tape can be also offered.

5) Working temperature: -60°C~90°C relative humidity: 55%±15%

Frequency range: 1GHz~18GHz

Model	Unit size B×B×H (mm×mm×mm)	Standard weight(Kg /m <sup>2</sup> )	Carton size(mm×mm×mm)	Qty per ctn (pcs)
Patron-ABS-LPPFA-T5	600×600×5	0,3	1280×605×605	256
Patron-ABS-LPPFA-T10	600×600×10	0,5	1280×605×605	128
Patron-ABS-LPPFA-T20	600×600×20	0,6	1280×605×605	64
Patron-ABS-LPPFA-T50	600×600×50	1,5	1280×605×605	26
Patron-ABS-LPPFA-T100	600×600×100	3	1280×605×605	13
Patron-ABS-LPPFA-TW40	600×600×40	1,5	1280×605×605	32

Model	Reflectivity (-dB@GHz)					
	1	3	6	10	18	40
Patron-ABS-LPPFA-T5				5	10	15
Patron-ABS-LPPFA-T10			10	15	15	18
Patron-ABS-LPPFA-T20		10	15	17	17	20
Patron-ABS-LPPFA-T50	10	18	18	19	19	20
Patron-ABS-LPPFA-T100	15	19	19	20	20	22
Patron-ABS-LPPFA-TW40	18	20	20	20	20	23