

# SL - 1W Series

# SCHMID-M

## 1W Unregulated Single & Dual output

### Features

- 7 Pin SIL Package
- 6000 VDC High Isolation
- Physical Clearance of Isolation Barrier 2.5mm
- Low Ripple and Noise
- Efficiency up to 81%
- Long Term Short Circuit Protection
- -40 ~ 85°C Operation Temperature Range
- 100% safety production test
- Rated working voltage for 250Vrms and 400Vdc
- Low coupling capacity
- Dedicated for IGBT applications



The SL series is a family of cost effective 1W single & dual output DC-DC converters. These converters achieve low cost and miniature SIP size without compromising performance. The bigger case ensures the physical clearance of isolation barrier of 2.5mm, which increases the reliability under hipot from 6KVDC. Devices are encapsulated with flame retardant resin. Input voltages are 5V,9V,12V,15V,24Vdc. with output voltage of 3.3V,5V,9V,12V,15V, ±3.3V, ±5V, ±9V, ±12V, ±15 and +15/-9Vdc. Special featuring long term output short circuit protection. Standard features include an input range of ±10% tolerance and low output noise and ripple.

All specifications typical at Ta=25°C, nominal input voltage and full load unless otherwise specified

OUTPUT SPECIFICATIONS	
Output Voltage Accuracy	±3% ,max.
Line Regulation	±1.2% / Per 1% Vin Change ,max.
Load Regulation	(From 10% to 100% Load) ±10% ,max.
Ripple & Noise(1) (20 Mhz bandwidth)	200mVpk-pk ,max.
Short Circuit Protection	Indefinite (Automatic Recovery)
Temperature Coefficient	±0.03%/°C
Capacitor Load(2)	See Table ,max.

INPUT SPECIFICATIONS	
Input Voltage Range	±10% ,max.
Input Current (Full-Load)	See Table ,typ.
Input Current (No-Load)	See Table ,max.
Input Filter	Capacitor
Input Reflected Ripple Current(3)	20mApk-pk ,typ.

GENERAL SPECIFICATIONS	
Efficiency	See table ,typ.
I/O Isolation Voltage(60sec)	6000Vdc
I/O Isolation Capacitance	10 pF ,typ.
I/O Isolation Resistance	1000MΩ ,min.
Switching Frequency	20~50KHz ,typ.
Humidity	95% rel H
Reliability Calculated MTBF(MIL-HDBK-217 F)	>2.39 Mhrs
Safety Standard : (designed to meet)	IEC 60950-1

ENVIRONMENT SPECIFICATIONS	
Operating Temperature	-40°C~85°C
Maximum Case Temperature	100°C
Storage Temperature	-40°C~125°C
Cooling	Nature Convection

PHYSICAL SPECIFICATIONS	
Clearance Distance	(Input to Output) 2.5 mm
Case Material	Epoxy encapsulated(UL94V-0 rated)
Pin Material	0.5mm Alloy 42 Solder-coated
Potting Material	Epoxy (UL94V-0 rated)
Weight	4.3g
Dimensions	0.77"x0.39"x0.49"

ABSOLUTE MAXIMUM RATINGS(4)	
These are stress ratings. Exposure of devices to any of these conditions may adversely affect long-term reliability.	
Input Surge Voltage(100mS)	
5 Models	7 Vdc ,max.
9 Models	12 Vdc ,max.
12 Models	15 Vdc ,max.
15 Models	18 Vdc ,max.
24 Models	28 Vdc ,max.
Soldering Temperature (1.5mm from case 10sec max.)	260°C ,max.

EMC SPECIFICATIONS		
Conducted Emissions(6)	EN55032	CLASS B
Radiated Emissions	EN55032	CLASS B
ESD	IEC 61000-4-2	Perf. Criteria A
RS	IEC 61000-4-3	Perf. Criteria A
EFT(7)	IEC 61000-4-4	Perf. Criteria A
CS	IEC 61000-4-6	Perf. Criteria A
PFMF	IEC 61000-4-8	Perf. Criteria A

## SL - 1W Unregulated Single & Dual output

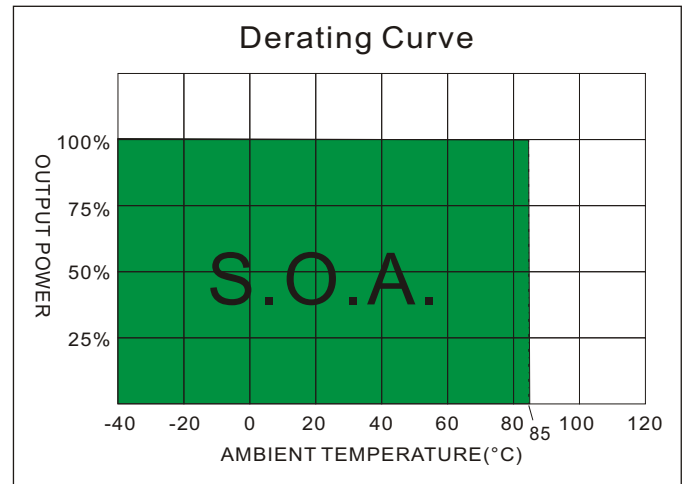
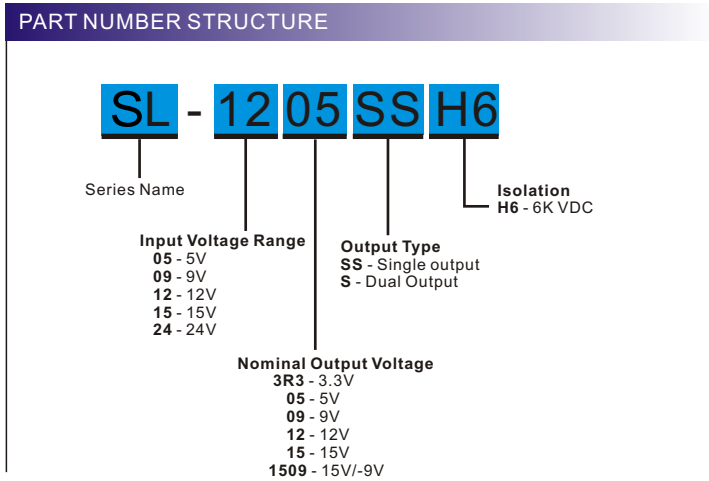

## MODEL SELECTION GUIDE

MODEL NUMBER	INPUT Voltage Range (Vdc)	INPUT Current		OUTPUT Voltage (Vdc)	OUTPUT Current Full load (mA)	EFFICIENCY @ FL (% ,typ.)	Capacitor Load @ FL (µF ,max.)
		No-Load (mA ,max.)	Full Load (mA ,typ.)				
SL-053R3SSH6	4.5-5.5	30	266.67	3R3	303.03	75	220
SL-0505SSH6	4.5-5.5	30	259.74	5	200	77	220
SL-0509SSH6	4.5-5.5	30	253.16	9	111.11	79	220
SL-0512SSH6	4.5-5.5	45	250.00	12	83.33	80	220
SL-0515SSH6	4.5-5.5	40	253.16	15	66.67	79	220
SL-093R3SSH6	8.1-9.9	20	146.20	3R3	303.03	76	220
SL-0905SSH6	8.1-9.9	25	144.30	5	200	77	220
SL-0909SSH6	8.1-9.9	25	138.89	9	111.11	80	220
SL-0912SSH6	8.1-9.9	25	135.50	12	83.33	82	220
SL-0915SSH6	8.1-9.9	25	135.50	15	66.67	82	220
SL-123R3SSH6	10.8-13.2	20	112.61	3R3	303.03	74	220
SL-1205SSH6	10.8-13.2	20	105.49	5	200	79	220
SL-1209SSH6	10.8-13.2	20	106.84	9	111.11	78	220
SL-1212SSH6	10.8-13.2	20	104.17	12	83.33	80	220
SL-1215SSH6	10.8-13.2	20	101.63	15	66.67	82	220
SL-153R3SSH6	13.5-16.5	15	86.58	3R3	303.03	77	220
SL-1505SSH6	13.5-16.5	15	84.39	5	200	79	220
SL-1509SSH6	13.5-16.5	15	82.30	9	111.11	81	220
SL-1512SSH6	13.5-16.5	15	81.30	12	83.33	82	220
SL-1515SSH6	13.5-16.5	15	81.30	15	66.67	82	220
SL-243R3SSH6	21.6-26.4V	15	56.31	3R3	303.03	74	220
SL-2405SSH6	21.6-26.4V	15	56.31	5	200	74	220
SL-2409SSH6	21.6-26.4V	15	55.56	9	111.11	75	220
SL-2412SSH6	21.6-26.4V	15	51.44	12	83.33	81	220
SL-2415SSH6	21.6-26.4V	15	52.74	15	66.67	79	220
SL-053R3SH6	4.5-5.5	30	270.27	±3R3	+/-151.52	74	±100
SL-0505SH6	4.5-5.5	30	253.16	±5	+/-100	79	±100
SL-0509SH6	4.5-5.5	30	246.91	±9	+/-55.56	81	±100
SL-0512SH6	4.5-5.5	40	250.00	±12	+/-41.67	80	±100
SL-0515SH6	4.5-5.5	40	250.00	±15	+/-33.33	80	±100
SL-093R3SH6	8.1-9.9	25	146.20	±3R3	+/-151.52	76	±100
SL-0905SH6	8.1-9.9	25	138.89	±5	+/-100	80	±100
SL-0909SH6	8.1-9.9	25	135.50	±9	+/-55.56	82	±100
SL-0912SH6	8.1-9.9	25	135.50	±12	+/-41.67	82	±100
SL-0915SH6	8.1-9.9	25	133.87	±15	+/-33.33	83	±100
SL-123R3SH6	10.8-13.2	20	109.65	±3R3	+/-151.52	76	±100
SL-1205SH6	10.8-13.2	20	108.23	±5	+/-100	77	±100
SL-1209SH6	10.8-13.2	20	104.17	±9	+/-55.56	80	±100
SL-1212SH6	10.8-13.2	20	102.88	±12	+/-41.67	81	±100
SL-1215SH6	10.8-13.2	20	102.88	±15	+/-33.33	81	±100

## MODEL SELECTION GUIDE

MODEL NUMBER	INPUT Voltage Range (Vdc)	INPUT Current		OUTPUT Voltage (Vdc)	OUTPUT Current Full load (mA)	EFFICIENCY @FL (% ,typ.)	Capacitor Load @FL (µF ,max.)
		No-Load (mA ,max.)	Full Load (mA ,typ.)				
SL-153R3SH6	13.5-16.5	15	86.58	±3R3	+/-151.52	77	±100
SL-1505SH6	13.5-16.5	15	82.30	±5	+/-100	81	±100
SL-1509SH6	13.5-16.5	15	80.32	±9	+/-55.56	83	±100
SL-1512SH6	13.5-16.5	15	79.37	±12	+/-41.67	84	±100
SL-1515SH6	13.5-16.5	15	78.43	±15	+/-33.33	85	±100
SL-243R3SH6	21.6-26.4V	15	58.69	±3R3	+/-151.52	71	±100
SL-2405SH6	21.6-26.4V	15	53.42	±5	+/-100	78	±100
SL-2409SH6	21.6-26.4V	15	52.74	±9	+/-55.56	79	±100
SL-2412SH6	21.6-26.4V	15	53.42	±12	+/-41.67	78	±100
SL-2415SH6	21.6-26.4V	15	50.81	±15	+/-33.33	82	±100
SL-051509SH6	4.5-5.5	40	250.00	+15/-9	+33.33/-55.55	80	±100
SL-091509SH6	8.1-9.9	25	135.50	+15/-9	+33.33/-55.55	82	±100
SL-121509SH6	10.8-13.2	20	105.49	+15/-9	+33.33/-55.55	79	±100
SL-151509SH6	13.5-16.5	12	77.52	+15/-9	+33.33/-55.55	86	±100
SL-241509SH6	21.6-26.4V	15	49.60	+15/-9	+33.33/-55.55	84	±100

### NOTE

1. Ripple/Noise measured with 20MHz bandwidth.
2. Tested by minimal Vin and constant resistive load.
3. Measured Input reflected ripple current with a simulated source inductance of 12µH and a source capacitor Cin(47µF, ESR<1.0Ω at 100KHz).
4. Exceeding the absolute ratings of the unit could cause damage. It is not allowed for continuous operating.
5. Operation under no-load conditions will not damage these devices, however they may not meet all listed specifications.
6. Input filter components are be required to help meet conducted emission class B, which application refer to the EMI Filter of design & feature configuration.
7. An external filter capacitor is required if the module has to meet IEC61000-4-4  
The filter capacitor SCHMID-M suggest: Nippon - chemi - con KY series, 470µF/100V.

**TEST CONFIGURATIONS**

**Input Reflected Ripple Current Test Step**

Input reflected ripple current is measured through a source inductor  $L_{in}$  (12 $\mu$ H) and a source capacitor  $C_{in}$  (47 $\mu$ F, ESR<1.0 $\Omega$  at 100KHz) at nominal input and full load.

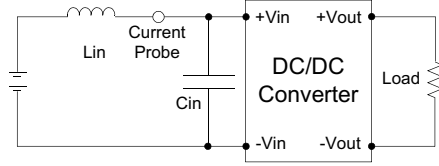

**Output Ripple & Noise Measurement Test**

The Scope measurement bandwidth is 20MHz .

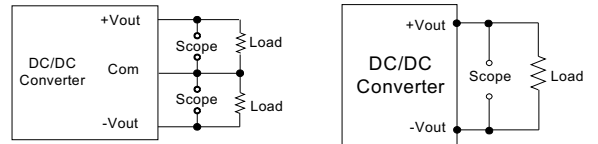

**EMI Filter**

Input filter components (C1, L, C2, C3) are used to help meet conducted emissions requirement for the module. These components should be mounted as close as possible to the module; and all leads should be minimized to decrease radiated noise.

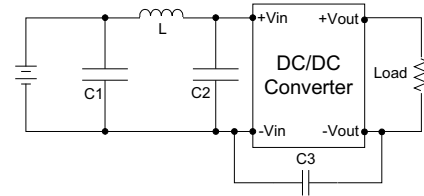

	C1	L	C2	C3
SL-05XXXXX	1210, 2.2 $\mu$ F/100V	18 $\mu$ H		
SL-09XXXXX	1210, 2.2 $\mu$ F/100V	18 $\mu$ H		
SL-12XXXXX	1210, 2.2 $\mu$ F/100V	18 $\mu$ H		
SL-15XXXXX	1210, 2.2 $\mu$ F/100V	18 $\mu$ H		
SL-24XXXXX	1210, 2.2 $\mu$ F/100V	18 $\mu$ H	1210, 2.2 $\mu$ F/100V	1206, 470pF/2KV

**MECHANICAL SPECIFICATIONS**

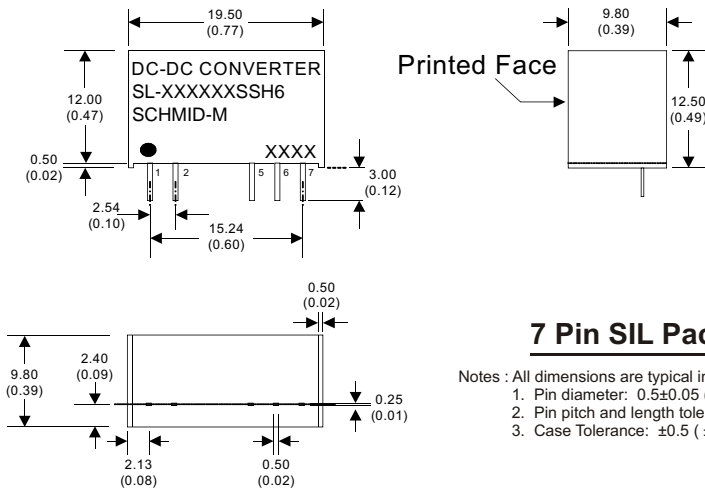

**7 Pin SIL Package**

- Notes : All dimensions are typical in millimeters ( inches ).
1. Pin diameter: 0.5 $\pm$ 0.05 ( 0.02 $\pm$ 0.002 )
  2. Pin pitch and length tolerance:  $\pm$ 0.35 (  $\pm$ 0.014 )
  3. Case Tolerance:  $\pm$ 0.5 (  $\pm$ 0.02 )

PIN CONNECTIONS		
PIN NUMBER	SINGLE	DUAL
1	+V Input	+V Input
2	-V Input	-V Input
5	-V Output	-V Output
6	N.P.	Common
7	+V Output	+V Output