

EMC & Inductors

Standard Series

CONTENT



Ferrites for cable assembly

		Page
	Round cable snap ferrites SMLF	1
	Flat Ferrite with Clip SRPS	2
	Flat Ferrite Cores SRP	3
	Toroidal Cores ST	4-5
	Axial Ferrite Beads SRH	6-7
	Ferrite Beads SDRH	8

Ferrites for PCB assembly

		Page
	Chip Bead SCB	9-13
	Chip Bead Array SCA	14-15
	Ferrite Bead SFB	16-18
	Ferrite Bead SSMB	19
	Bead Array SSMA	20
	5-Hole Ferrite Bead SR5H	21
	6-Hole Ferrite Bead SR6H	22-23

Inductors

		Page
	SMD Multilayer Chip Inductor SCI	24-26
	SMD RF Multilayer Chip Inductor SCI-C	27-28
	SMD Wire Wound Inductor SWI	29-31
	Wire wound ferrite chip inductor- SFL series	32-33
	SMD Wire Wound Inductor SWI1008P	34
	RF Wire Wound Inductor SWI-C	35-37
	RF Wire Wound Inductor SWI-L	38-39
	SMD Air Coil SAS	40
	Axial Choke SEC	41-43
	Leaded Wire Wound Inductor SPK	44
	Wire Wound Rodcore Inductor SR	45
	Toroidal Line Choke STI	46
	Flat Inductor SFC	47
	Leaded Line Filter SQT02	48
	Leaded Common Choke SQT04	49
	Current Compensated Choke SCC	50
	SMD Current-Compensated Nanocrystalline Choke - SCC-SMD series	51
	Current-Compensated Nanocrystalline Choke - SCCN series	52
	Current-Compensated Nanocrystalline Choke - SCCON series	53
	SMD Power Inductor STP	54-55

		Page
	SMD Power Inductor SSPK	56
	SMD Power Inductor SDO	57
	SMD RF Inductor SQH	58-59
	SMD Power Inductor SSPK0402	60
	SMD Power Inductor SSPH	61
	SMD Power Inductor SVLP	62
	SMD Power Inductor SCMD	63
	SMD Shielded Power Inductor SPRD	64-65
	SMD Shielded Power Inductor- SPRD02 series	66
	SMD Shielded Power Inductor SPRD1004	67
	SMD Shielded Power Inductor SPRH	68
	SMD Shielded Power Transformers- SPRH-DD series	69
	SMD Shielded Power Inductor SSPS	70
	SMD Shielded Power Inductor - SSPS0403 Series	71
	SMD Shielded Power Inductor SSB	72
	SMD common mode choke wire wound type - SPWC series	73
	SMD dual common mode choke SM6560	74
	Common Mode Filters - SMD -SID series	75
	SMD Shielded Power Inductor-SSRP series	76
	SMD Shielded Power Inductor - SSIH Series	77

Remark: Please note that these are our standard parts. Other parts are available on request.
Please send your inquiry to the Sales Partner near you or directly to:

SCHMID-MULTITECH GmbH
T:+49-9403-9510-0
F:+49-9403-4251
Email: info@schmid-m.com

SCHMID-MULTITECH s.r.o.
T:+421-32-7440186
F:+421-32-7440187
Email: rstraka@smsk.sk



Round cable snap ferrite – SMLF Series



Features

- Dataline Noise Filter is hinged clamp and also has EMI performance
- Internal dimensions from 1.9mm to 35mm radius
- Precision formed smooth surface prevent damage to wire insulation
- Customer designs available

Ordering Information

SMLF 65

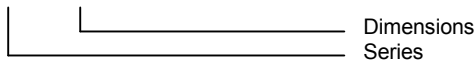

Characteristics

Part No.	Impedance (Ω)	
	25MHz	100MHz
SMLF-35	80	200
SMLF-50	85	150
SMLF-65	125	275
SMLF-75	130	240
SMLF-80	110	180
SMLF-90	150	270
SMLF-100	150	270
SMLF-120	50	100
SMLF-130	140	300
SMLF-150	30	125

Shapes

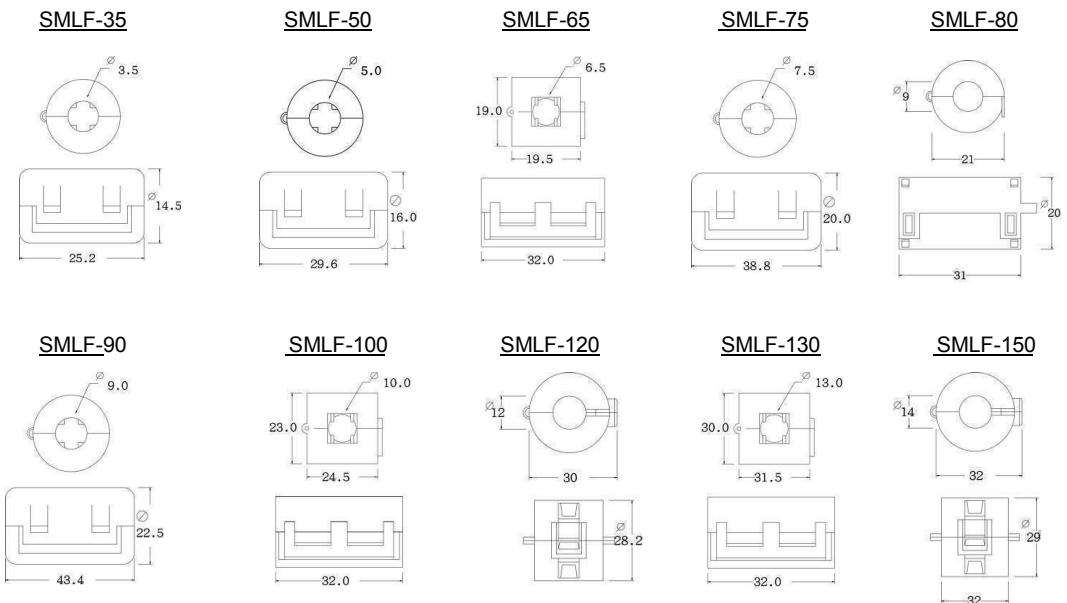

Flat Ferrite with Clip – SRPS Series

SCHMID-M

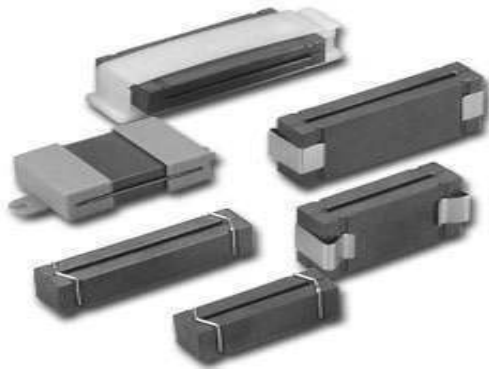

Ordering Information

SRPS 63.5x6.35x28.5 N1

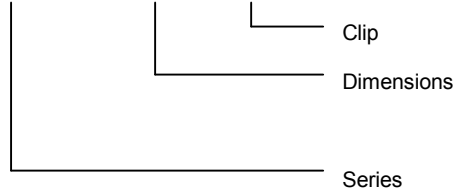

Features

- Precision formed smooth surfaces prevent damage to wire insulation.
- Applications: Cables between pc boards and data connectors, floppy disk and hard cables with series digital signal busses.

Shapes

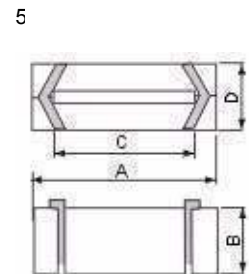
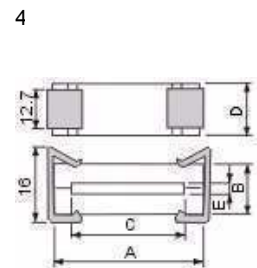
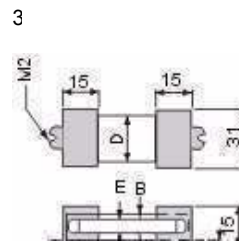
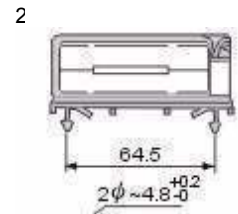
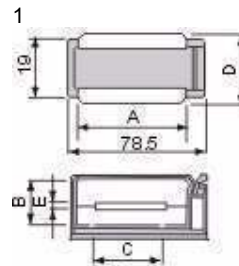

Clip Material

N1, N2, N3: Nylon-66 (UL)
Flame Class: 94V-2

M1: Spring Steel
Nickel C coating

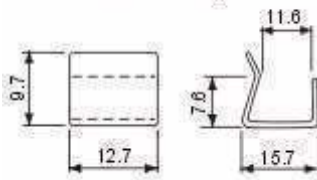

M2: Piano wire
Nickel C coating

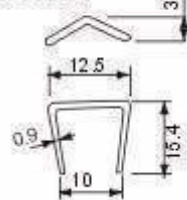

Characteristics

Part No.	Fig.	A	B	C	D	E	Curve	Impedance (Ω) min	
								25MHz	100MHz
SRPS38.0x6.35x15.0M2	5	38.0 ± 1.0	12.7 ± 0.5	26.6 ± 0.7	15.0 ± 0.4	1.6 ± 0.4	A	40	115
SRPS38.0x6.35x25.4M1	4	38.0 ± 1.0	12.7 ± 0.5	26.6 ± 0.7	25.4 ± 0.7	1.6 ± 0.4	B	75	140
SRPS45.0x6.35x15.0M2	5	45.0 ± 1.0	12.7 ± 0.5	34.4 ± 0.7	15.0 ± 0.4	1.6 ± 0.4	C	40	90
SRPS45.0x6.35x28.5M1	4	45.0 ± 1.0	12.7 ± 0.5	34.4 ± 0.7	28.5 ± 0.7	1.6 ± 0.4	D	70	140
SRPS45.0x6.35x28.5N3	3	45.0 ± 1.0	12.7 ± 0.5	34.4 ± 0.7	28.5 ± 0.7	1.6 ± 0.4	D	70	140
SRPS55.1x6.35x15.0M2	5	55.1 ± 1.0	12.7 ± 0.5	43.7 ± 1.0	15.0 ± 0.4	1.6 ± 0.4	E	40	105
SRPS55.1x6.35x28.5M1	4	55.1 ± 1.0	12.7 ± 0.5	43.7 ± 1.0	28.5 ± 0.7	1.6 ± 0.4	F	65	140
SRPS55.1x6.35x28.5N3	3	55.1 ± 1.0	12.7 ± 0.5	43.7 ± 1.0	28.5 ± 0.7	1.6 ± 0.4	F	65	140
SRPS63.5x6.35x15.0M2	5	63.5 ± 1.2	12.7 ± 0.5	52.0 ± 1.0	15.0 ± 0.4	1.6 ± 0.4	G	40	95
SRPS63.5x6.35x28.5M1	4	63.5 ± 1.2	12.7 ± 0.5	52.0 ± 1.0	28.5 ± 0.7	1.6 ± 0.4	H	60	150
SRPS63.5x6.35x28.5N1	1	63.5 ± 1.2	12.7 ± 0.5	52.0 ± 1.0	28.5 ± 0.7	1.6 ± 0.4	H	60	150
SRPS63.5x6.35x28.5N2	2	63.5 ± 1.2	12.7 ± 0.5	52.0 ± 1.0	28.5 ± 0.7	1.6 ± 0.4	H	60	150
SRPS63.5x6.35x28.5N3	3	63.5 ± 1.2	12.7 ± 0.5	52.0 ± 1.0	28.5 ± 0.7	1.6 ± 0.4	H	60	150
SRPS76.2x6.35x28.5M1	1	76.2 ± 1.5	12.7 ± 0.5	65.2 ± 1.2	28.5 ± 0.7	1.6 ± 0.4	I	60	190
SRPS76.2x6.35x28.5N3	3	76.2 ± 1.5	12.7 ± 0.5	65.2 ± 1.2	28.5 ± 0.7	1.6 ± 0.4	I	60	190

Flat Ferrite Cores – SRP Series



Features

- Slot lengths from 16mm to 60mm. Precision formed smooth surfaces prevent damage to wire insulation
- Applications: Internal floppy disk and harddisk ribbon cables. Internal ribbon cables between circuit boards and data connectors. Internal ribbon cables with series digital signal busses

Shapes

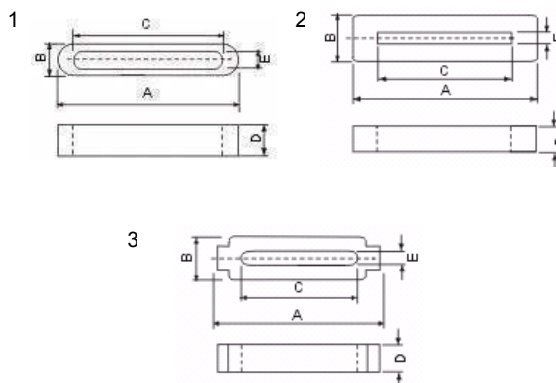

Ordering Information

SRP 31.0x5.0x12.0

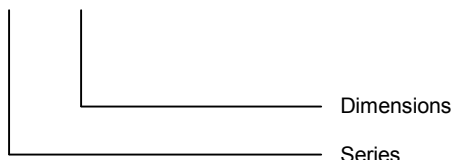

Characteristics

Shape#3: SRP2877146
 Shape#2: SRP22357751905 / SRP23337 / SRP2356310 / SRP287722 / SRP38112254 / SRP45112510 / SRP451125286
 Shape#1: all other parts

Part No.	A	B	C	D	E	Impedance (Ω) min	
						25MHz	100MHz
SRP16.0x5.0x11.5	16.0 ± 0.4	5.0 ± 0.3	11.5 ± 0.4	12.0 ± 0.5	0.5 +0.6 -0.1	44	90
SRP16.0x5.0x11.5	16.0 ± 0.4	5.0 ± 0.3	11.5 ± 0.4	15.0 ± 0.6	0.5 +0.6 -0.1	50	110
SRP18.0x5.0x8.0	18.0 ± 0.4	5.0 ± 0.3	14.0 ± 0.4	8.0 ± 0.4	1.0 ± 0.3	24	55
SRP20.5x3.5x15.0	20.5 ± 0.5	3.5 +0.15 -0.25	16.5 ± 0.4	15.0 ± 0.6	0.5 +0.2 -0.15	34	88
SRP22.35x7.75x19.05	22.35 ± 0.51	7.75 ± 0.38	14.0 ± 0.25	19.05 ± 0.64	1.5 ± 0.25	68	120
SRP23.3x3.0x7.0	23.3 ± 0.7	3.0 ± 0.3	20.0 ± 0.5	7.0 ± 0.4	0.9 ± 0.15	20	60
SRP23.5x6.3x10.0	23.5 ± 0.7	6.3 ± 0.5	18.4 ± 0.4	10.0 ± 0.4	1.1 ± 0.3	32	75
SRP25.0x5.0x12.0	25.0 ± 0.7	5.0 ± 0.4	21.0 ± 0.5	12.0 ± 0.5	1.1 ± 0.2	27	75
SRP25.0x3.5x15.0	25.0 ± 0.8	3.5 +0.15 -0.25	24.0 ± 0.4	15.0 ± 0.6	0.5 +0.2 -0.15	30	88
SRP28.0x6.5x15.0	28.0 ± 0.8	6.5 ± 0.5	23.0 ± 0.5	15.0 ± 0.6	1.0 ± 0.3	30	85
SRP28.5x6.5x18.0	28.5 ± 0.8	6.5 ± 0.5	23.5 ± 0.5	18.0 ± 0.7	1.0 ± 0.3	40	95
SRP28.0x7.7x14.6	28.0 ± 0.8	7.7 ± 0.5	23.0 ± 0.5	14.6 ± 0.4	1.4 ± 0.4	38	85
SRP28.0x7.7x22.0	28.0 ± 0.8	7.7 ± 0.5	23.0 ± 0.5	22.0 ± 0.6	1.4 ± 0.4	52	110
SRP28.6x7.7x25.0	28.6 ± 0.85	7.7 ± 0.5	23.6 ± 0.8	25.0 ± 0.8	1.8 ± 0.4	45	95
SRP31.0x5.0x8.0	31.0 ± 0.8	5.0 ± 0.4	27.0 ± 0.6	8.0 ± 0.4	0.5 +0.7 -0.1	21	60
SRP31.0x5.0x9.0	31.0 ± 0.8	5.0 ± 0.4	27.0 ± 0.6	9.0 ± 0.4	0.5 +0.7 -0.1	25	75
SRP31.0x5.0x12.0	31.0 ± 0.8	5.0 ± 0.4	27.0 ± 0.6	12.0 ± 0.5	0.5 +0.7 -0.1	30	85
SRP31.0x5.0x22.0	31.0 ± 0.8	5.0 ± 0.4	27.0 ± 0.6	22.0 ± 0.6	0.5 +0.7 -0.1	46	130
SRP33.5x3.5x15.0	33.5 ± 0.9	3.5 ± 0.3	27.0 ± 0.6	15.0 ± 0.6	1.4 ± 0.4	21	68
SRP33.5x4.0x12.0	33.5 ± 0.9	4.0 +0 -0.2	27.0 ± 0.6	12.0 ± 0.5	1.4 ± 0.4	19	60
SRP33.5x6.5x7.0	33.5 ± 0.9	6.5 ± 0.5	27.0 ± 0.6	7.0 ± 0.4	1.4 ± 0.4	20	57
SRP33.5x6.5x8.0	33.5 ± 0.9	6.5 ± 0.5	27.0 ± 0.6	8.0 ± 0.4	1.4 ± 0.4	21	60
SRP33.5x6.5x10.0	33.5 ± 0.9	6.5 ± 0.5	27.0 ± 0.6	10.0 ± 0.4	1.4 ± 0.4	24	65
SRP33.5x6.5x15.0	33.5 ± 0.9	6.5 ± 0.5	27.0 ± 0.6	15.0 ± 0.6	1.4 ± 0.4	32	81
SRP33.5x6.5x22.0	33.5 ± 0.9	6.5 ± 0.5	27.0 ± 0.6	22.0 ± 0.6	1.4 ± 0.4	43	95
SRP38.1x12.0x25.4	38.1 ± 1.0	12.0 ± 0.6	26.7 ± 0.6	25.4 ± 0.8	1.9 ± 0.4	83	145
SRP40.0x6.5x6.0	40.0 ± 1.0	6.5 ± 0.5	35.0 ± 0.7	6.0 ± 0.3	1.4 ± 0.4	16	50
SRP40.0x6.5x12.0	40.0 ± 1.0	6.5 ± 0.5	35.0 ± 0.7	12.0 ± 0.5	1.4 ± 0.4	25	72
SRP40.0x6.5x18.0	40.0 ± 1.0	6.5 ± 0.5	35.0 ± 0.7	18.0 ± 0.5	1.4 ± 0.4	32	84
SRP40.0x6.5x20.0	40.0 ± 1.0	6.5 ± 0.5	35.0 ± 0.7	20.0 ± 0.6	1.4 ± 0.4	35	88
SRP40.0x6.5x22.0	40.0 ± 1.0	6.5 ± 0.5	35.0 ± 0.7	22.0 ± 0.6	1.4 ± 0.4	37	95
SRP45.1x12.5x10.0	45.1 ± 1.0	12.5 ± 0.6	34.5 ± 0.8	10.0 ± 0.4	1.5 ± 0.5	30	72
SRP45.1x12.5x28.6	45.1 ± 1.0	12.5 ± 0.6	34.5 ± 0.8	28.6 ± 0.8	1.5 ± 0.5	80	165
SRP45.2x6.5x12.0	45.2 ± 1.0	6.5 ± 0.5	40.0 ± 0.8	12.0 ± 0.5	1.4 ± 0.4	24	72
SRP49.6x4.0x12.0	49.6 ± 1.0	4.0 ± 0.2	44.0 ± 0.8	12.0 ± 0.5	1.4 ± 0.4	19	63
SRP49.6x6.5x12.0	49.6 ± 1.0	6.5 ± 0.5	44.0 ± 0.8	12.0 ± 0.5	1.4 ± 0.4	22	68
SRP57.6x6.5x12.0	57.6 ± 1.2	6.5 ± 0.5	52.0 ± 1.0	12.0 ± 0.5	1.4 ± 0.4	22	70
SRP60.6x6.5x12.0	60.6 ± 1.2	6.5 ± 0.5	55.0 ± 1.0	12.0 ± 0.5	1.4 ± 0.4	28	92

Toroidal Cores – ST Series

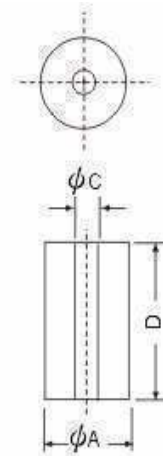

Features

- Minimal effect on transmission waveforms
- Low cost noise countermeasure
- Application: LAN matching and isolation transformers, EMI Filters, Power Supplies etc.

Ordering Information

ST 6.0x3.0x3.0

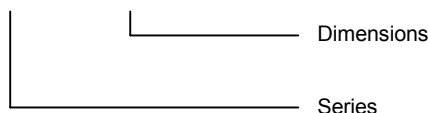

Characteristic

Part No.	A	C	D	Material	Curve	A _L (nH)	Impedance (Ω) min	
							25MHz	100MHz
ST4.5x1.5x3.5	4.5 ± 0.2	1.5 ± 0.15	3.5 ± 0.2	K5A		490	70	100
ST5.08x2.36x4.8	5.08 ± 0.2	2.36 ± 0.15	4.8 ± 0.3	K5A		491	310	490
ST7.0x3.5x4.0	7.0 ± 0.2	3.5 ± 0.2	4.0 ± 0.3	K5A		373	15	45
ST7.62x3.18x4.78	7.62 ± 0.2	3.18 ± 0.2	4.78 ± 0.3	K6		1179	25	50
ST9.4x6.3x5.0	9.4 ± 0.3	6.3 ± 0.3	6.2 ± 0.3	K5A		343	10	25
ST9.5x5.02x5.0	9.5 ± 0.3	5.02 ± 0.3	5.0 ± 0.3	K5A		432	20	35
ST9.5x5.0x5.0	9.5 ± 0.3	5.0 ± 0.3	5.0 ± 0.3	K5A		434	20	35
ST9.65x5.02x4.83	9.65 ± 0.3	5.02 ± 0.25	4.83 ± 0.2	K6			10	30
ST9.65x5.0x5.05	9.65 ± 0.3	5.0 ± 0.2	5.05 ± 0.3	K5A		449	21	43
ST10.0x5.1x9.0	10.0 ± 0.3	5.1 ± 0.25	9.0 ± 0.3	P1B		673	30	60
ST10.0x7.0x5.0	10.0 ± 0.3	7.0 ± 0.3	5.0 ± 0.3	K5A		247	15	40
ST12.0x7.0x5.5	12.0 ± 0.3	7.0 ± 0.3	5.5 ± 0.3	K5A		405	15	40
ST12.7x7.9x6.35	12.7 ± 0.3	7.9 ± 0.3	6.35 ± 0.3	K5A	5	414	21	42
ST13.0x7.0x3.0	13.0 ± 0.3	7.0 ± 0.3	3.0 ± 0.2	K5A		252	15	30
ST14.0x8.7x7.0	14.0 ± 0.4	8.7 ± 0.3	7.0 ± 0.3	K5A		458	25	45
ST14.2x4.5x6.0	14.2 ± 0.4	4.5 ± 0.4	6.0 ± 0.3	K5		1245	35	85
ST14.2x6.35x13.8	14.2 ± 0.4	6.35 ± 0.3	13.8 ± 0.4	K5A		1476	60	100
ST14.5x10.5x8.0	14.5 ± 0.4	10.5 ± 0.4	8.0 ± 0.3	K5A		358	15	45
ST15.9x7.9x14.3	15.9 ± 0.4	7.9 ± 0.3	14.3 ± 0.4	K5A		1346	60	100
ST16.0x8.0x13.0	16.0 ± 0.4	8.0 ± 0.3	13.0 ± 0.4	K5A	10	1213	45	90
ST16.5x8.2x13.0	16.5 ± 0.4	8.2 ± 0.3	13.0 ± 0.4	K5A		1223	45	100
ST17.5x9.5x12.7	17.5 ± 0.4	9.5 ± 0.3	12.7 ± 0.4	K5A	14	1054	45	70
ST18.3x10.0x10.0	18.3 ± 0.5	10.0 ± 0.4	10.0 ± 0.4	K5A	17		30	80
ST18.4x9.5x15.0	18.4 ± 0.5	9.5 ± 0.3	15.0 ± 0.4	K5A		1340	50	85
ST18.4x9.6x12.0	18.4 ± 0.5	9.6 ± 0.3	12.0 ± 0.4	K5A		1056	45	80
ST18.7x10.2x17.0	18.7 ± 0.5	10.2 ± 0.4	17.0 ± 0.4	K5A		1400	45	80
ST20.0x10.0x10.0	20.0 ± 0.6	10.0 ± 0.4	10.0 ± 0.4	K5A	20	933	140	250
ST20.7x12.0x14.0	20.7 ± 0.6	12.0 ± 0.4	14.0 ± 0.4	K5A		980	140	250
ST21.0x13.2x12.0	21.0 ± 0.6	13.2 ± 0.4	12.0 ± 0.4	K5A		776	30	65
ST21.2x12.7x6.1	21.2 ± 0.6	12.7 ± 0.4	6.1 ± 0.3	K5A		428	30	65
ST22.0x13.5x8.0	22.0 ± 0.6	13.5 ± 0.4	8.0 ± 0.3	K5A		536	30	60
ST22.0x14.0x8.0	22.0 ± 0.6	14.0 ± 0.4	8.0 ± 0.3	K5A		498	30	60
ST22.1x13.7x6.35	22.1 ± 0.6	13.7 ± 0.4	6.35 ± 0.3	K5A			15	45
ST22.5x13.8x6.4	22.5 ± 0.6	13.8 ± 0.4	6.4 ± 0.3	K5A	21		15	45
ST22.5x13.8x12.8	22.5 ± 0.6	13.8 ± 0.4	12.8 ± 0.4	K5A	22		40	80
ST23.0x11.0x14.0	23.0 ± 0.6	11.0 ± 0.4	14.0 ± 0.4	K5A		1384	60	110



Part No.	A	C	D	Material	Curve	A _L (nH)	Impedance (Ω)	
							min	
							25MHz	100MHz
ST23.0x13.5x6.34	23.0 ± 0.6	13.5 ± 0.4	6.34 ± 0.4	K5A		463	15	45
ST23.5x12.6x9.4	23.5 ± 0.6	12.6 ± 0.4	9.4 ± 0.3	K6A		1703	60	120
ST24.0x11.0x14.0	24.0 ± 0.6	11.0 ± 0.4	14.0 ± 0.4	K5A		1456	60	100
ST24.0x14.0x11.0	24.0 ± 0.6	14.0 ± 0.4	11.0 ± 0.4	K5A			35	63
ST25.0x15.0x12.0	25.0 ± 0.6	15.0 ± 0.5	12.0 ± 0.4	K5A		467	35	80
ST28.0x16.0x13.0	28.0 ± 0.6	16.0 ± 0.3	13.0 ± 0.4	K6	26	993	40	80
ST29.0x19.0x7.5	29.0 ± 0.6	19.0 ± 0.5	7.5 ± 0.3	K5A		438	20	50
ST31.0x19.0x8.0	31.0 ± 0.9	19.0 ± 0.5	8.0 ± 0.3	K5	27		25	60
ST31.75x19.05x16.0	31.75 ± 0.8	19.05 ± 0.5	16.0 ± 0.4	K5A	28		50	90
ST31.75x19.05x22.5	31.75 ± 0.8	19.05 ± 0.8	22.5 ± 0.6	K5A			60	90
ST35.6x23.0x12.7	35.6 ± 0.8	23.0 ± 0.6	12.7 ± 0.4	K5A	29	765	25	90
ST35.6x5.4x7.5	35.6 ± 0.8	25.4 ± 0.6	7.5 ± 0.2	K5A	30	351	25	90
ST40.6x27.5x15.0	40.6 ± 1.0	27.5 ± 0.6	15.0 ± 0.4	K5A		808	35	85
ST40.6x27.0x15.0	40.6 ± 1.0	27.0 ± 0.6	15.0 ± 0.4	K5A		845	35	85

5

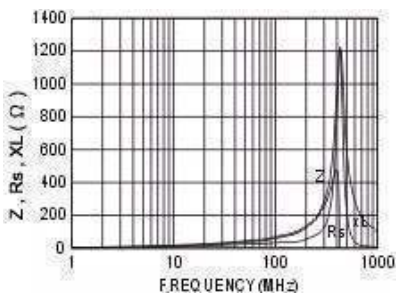

10

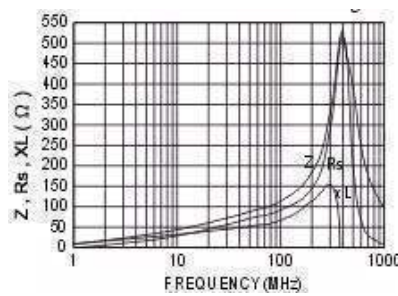

14

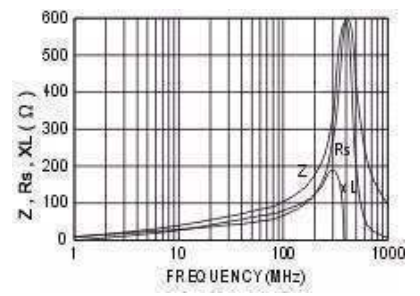

17

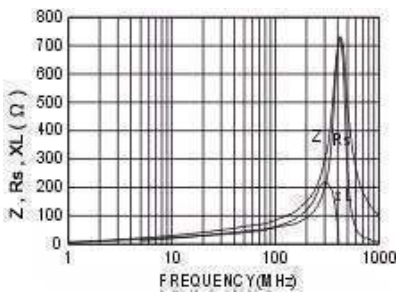

20

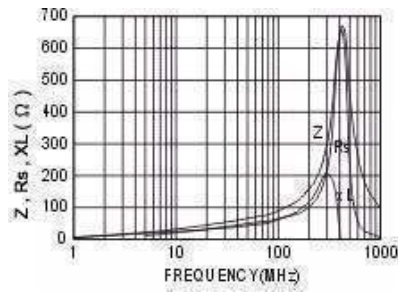

21

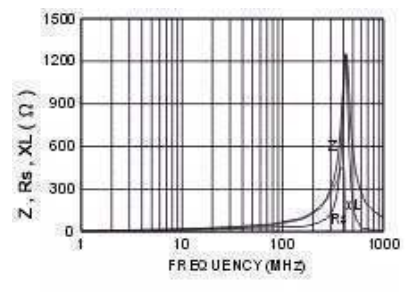

22

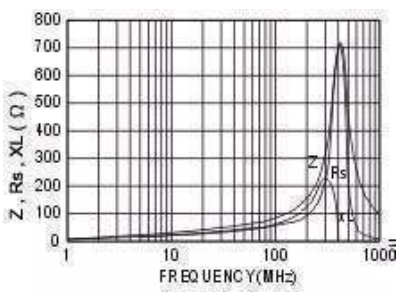

26

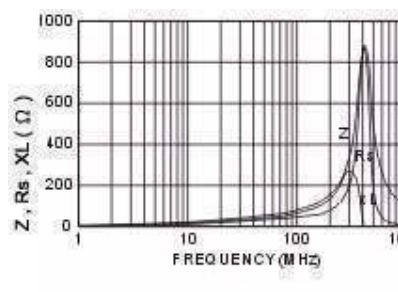

27

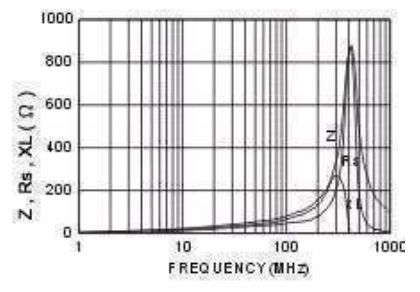

28

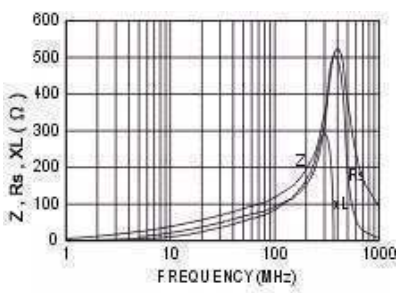

29

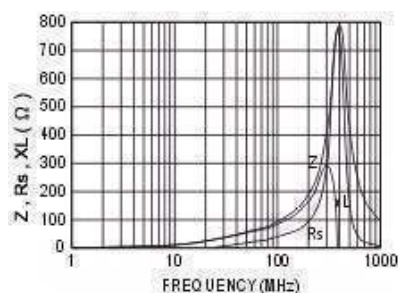

30

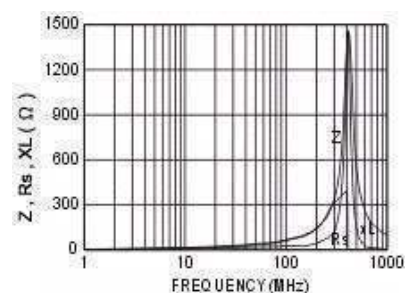

Axial Ferrite Bead – SRH Series

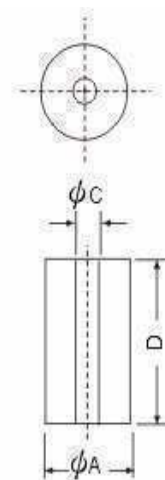

Features

- Employ High-Performance ferrites with superior frequency characteristic. Compact and high performance. Easy installation.
- Countermeasure against radiated emissions – full compliance with FCC

Ordering Information

SRH 11.0x5.0x25.0

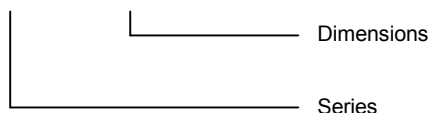

Characteristic

Part No.	A	C	D	Material	Curve	Impedance (Ω) min	
						25MHz	100MHz
SRH2.5x0.8x3.0	2.5 ± 0.15	0.8 ± 0.15	3.0 ± 0.2	K5A		20	30
SRH2.5x1.0x3.0	2.5 ± 0.15	1.0 ± 0.15	3.0 ± 0.2	K5A		10	30
SRH3.5x0.9x6.0	3.5 ± 0.15	0.9 ± 0.1	6.0 ± 0.3	K5A		50	75
SRH3.5x1.3x3.0	3.5 ± 0.15	1.3 ± 0.1	3.0 ± 0.2	K5A		10	20
SRH3.5x1.0x5.0	3.5 ± 0.15	1.0 ± 0.15	5.0 ± 0.3	K5A		20	45
SRH4.0x2.0x15.0	4.0 ± 0.2	2.0 ± 0.15	15.0 ± 0.5	K5		50	80
SRH4.0x2.0x25.0	4.0 ± 0.2	2.0 ± 0.15	25.0 ± 0.3	K5A		90	120
SRH4.0x2.2x6.0	4.0 ± 0.2	2.2 ± 0.15	6.0 ± 0.3	K5A		20	40
SRH4.0x2.2x25.0	4.0 ± 0.2	2.2 ± 0.15	25.0 ± 0.6	K5A		90	120
SRH4.1x2.0x6.0	4.1 ± 0.2	2.0 ± 0.15	6.0 ± 0.3	K5A		20	30
SRH4.2x2.0x15.0(R)	4.2 ± 0.2	2.0 ± 0.15	15.0 ± 0.4	C3B		45	90
SRH4.2x2.0x15.0(C)	4.2 ± 0.2	2.0 ± 0.15	15.0 ± 0.4	C3B		45	90
SRH4.5x1.5x7.0	4.5 ± 0.2	1.5 ± 0.1	7.0 ± 0.3	K5		40	80
SRH4.5x2.5x7.0	4.5 ± 0.2	2.5 ± 0.15	7.0 ± 0.3	K5A		35	65
SRH4.9x2.0x36.0	4.9 ± 0.2	2.0 ± 0.15	36.0 ± 0.8	K6		140	200
SRH5.08x2.29x10	5.08 ± 0.2	2.29 ± 0.15	10.0 ± 0.4	K5A		40	65
SRH6.35x2.95x25.4	6.35 ± 0.2	2.95 ± 0.15	25.4 ± 0.6	K5A		108	200
SRH6.35x3.2x12.7	6.35 ± 0.2	3.2 ± 0.2	12.7 ± 0.4	K5A		55	102
SRH6.5x4.0x10.0	6.5 ± 0.2	4.0 ± 0.2	10.0 ± 0.4	K5A		20	40
SRH6.5x4.5x10.0	6.5 ± 0.2	4.5 ± 0.2	10.0 ± 0.4	K5A		15	35
SRH7.52x2.39x7.54	7.52 ± 0.2	2.39 ± 0.15	7.54 ± 0.3	K5A		30	60
SRH7.8x4.0x13.0	7.8 ± 0.2	4.0 ± 0.2	13.0 ± 0.4	K5A		45	80
SRH7.8x5.0x12.5	7.8 ± 0.2	5.0 ± 0.25	12.5 ± 0.4	K5A		30	60
SRH8.0x5.3x15.0	8.0 ± 0.2	5.3 ± 0.25	15.0 ± 0.4	K5A		40	80
SRH9.0x5.0x16.0	9.0 ± 0.3	5.0 ± 0.25	16.0 ± 0.4	K5A		50	80
SRH9.05x4.7x16.2	9.05 ± 0.3	4.7 ± 0.2	16.2 ± 0.4	K5A		60	110
SRH9.5x4.8x14.5	9.5 ± 0.3	4.8 ± 0.2	14.5 ± 0.4	K5A		53	75
SRH9.5x5.0x14.5	9.5 ± 0.3	5.0 ± 0.25	14.5 ± 0.4	K5A		50	100
SRH9.5x5.2x9.5	9.5 ± 0.3	5.2 ± 0.25	9.5 ± 0.4	K5A		35	65
SRH9.65x5.02x10.4	9.65 ± 0.3	5.02 ± 0.25	10.4 ± 0.4	K5A		30	60
SRH9.7x3.8x10.2	9.7 ± 0.3	3.8 ± 0.2	10.2 ± 0.4	K5A		60	100
SRH9.8x6.3x15.7	9.8 ± 0.3	6.3 ± 0.3	15.7 ± 0.4	K5A		45	65
SRH10.0x5.0x25.0	10.0 ± 0.3	5.0 ± 0.25	25.0 ± 0.6	K5A		125	160



Part No.	A	C	D	Material	Curve	Impedance (Ω) min	
						25MHz	100MHz
SRH10.0x5.5x2.5	10.0 ± 0.3	5.5 ± 0.25	2.5 ± 0.6	K5A		90	160
SRH10.0x6.0x14.0	10.0 ± 0.3	6.0 ± 0.3	14.0 ± 0.4	K5A		35	75
SRH10.0x6.15x6.2	10.0 ± 0.3	6.15 ± 0.3	6.2 ± 0.3	K5A		45	85
SRH10.0x7.0x10.0	10.0 ± 0.3	7.0 ± 0.3	10.0 ± 0.4	K5A		20	40
SRH10.5x5.5x20.0	10.5 ± 0.3	5.5 ± 0.25	20.0 ± 0.5	K5A		65	120
SRH11.0x5.0x25.0	11.0 ± 0.3	5.0 ± 0.25	25.0 ± 0.6	K5A		115	180
SRH11.3x5.95x12.0	11.3 ± 0.3	5.95 ± 0.25	12.0 ± 0.4	K5A		40	70
SRH11.86x7.4x15.0	11.86 ± 0.3	7.4 ± 0.3	15.0 ± 0.4	K5A		35	75
SRH12.0x4.0x23.0	12.0 ± 0.3	4.0 ± 0.2	23.0 ± 0.5	K5A	4	160	230
SRH12.0x5.6x20.0	12.0 ± 0.3	5.6 ± 0.25	20.0 ± 0.5	K5A	3	100	200
SRH12.0x8.0x13.0	12.0 ± 0.3	8.0 ± 0.3	13.0 ± 0.4	K5A		35	75
SRH12.0x8.5x15.0	12.0 ± 0.3	8.5 ± 0.3	15.0 ± 0.4	K5A		30	50
SRH12.3x5.0x12.7	12.3 ± 0.3	5.0 ± 0.25	12.7 ± 0.4	K5A		60	120
SRH12.7x6.0x21.7	12.7 ± 0.3	6.0 ± 0.3	21.7 ± 0.5	K6		85	135
SRH12.7x7.9x12.7	12.7 ± 0.3	7.9 ± 0.3	12.7 ± 0.4	K5A		30	60
SRH13.0x7.0x15.0	13.0 ± 0.3	7.0 ± 0.3	15.0 ± 0.4	P3		75	140
SRH14.0x6.8x15.0	14.0 ± 0.4	6.8 ± 0.3	15.0 ± 0.4	K5		65	120
SRH14.0x7.8x15.0	14.0 ± 0.4	7.8 ± 0.3	15.0 ± 0.4	K5A		35	70
SRH14.2x4.5x28.5	14.2 ± 0.4	4.5 ± 0.2	28.5 ± 0.6	K5A		160	300
SRH14.2x6.35x28.5	14.2 ± 0.4	6.35 ± 0.3	28.5 ± 0.6	K5A	7	100	190
SRH14.2x6.35x36.0	14.2 ± 0.4	6.35 ± 0.3	36.0 ± 0.8	K5A		150	280
SRH14.2x7.2x28.5	14.2 ± 0.4	7.2 ± 0.3	28.5 ± 0.6	K5A		130	210
SRH14.2x7.0x28.5	14.2 ± 0.4	7.0 ± 0.3	28.5 ± 0.6	K5A	8	100	120
SRH14.2x8.0x23.5	14.2 ± 0.4	8.0 ± 0.3	23.5 ± 0.5	K5A		65	135
SRH14.2x8.0x28.5	14.2 ± 0.4	8.0 ± 0.3	28.5 ± 0.6	K5A		60	150
SRH14.2x9.15x28.5	14.2 ± 0.4	9.15 ± 0.3	28.5 ± 0.6	K5A		100	170
SRH14.2x9.0x15.0	14.2 ± 0.4	9.0 ± 0.3	15.0 ± 0.4	K5A		50	100
SRH14.3x6.35x23.3	14.3 ± 0.4	6.35 ± 0.3	23.3 ± 0.5	K5A		100	180
SRH14.3x9.15x28.5	14.3 ± 0.4	9.15 ± 0.3	28.5 ± 0.6	K5A		75	120
SRH14.3x9.0x28.5	14.3 ± 0.4	9.0 ± 0.3	28.5 ± 0.6	K5A		75	120
SRH15.7x10.5x28.5	15.7 ± 0.4	10.5 ± 0.3	28.5 ± 0.6	K5A		60	100
SRH15.7x7.3x28.5	15.7 ± 0.4	7.3 ± 0.3	28.5 ± 0.6	K5A		90	180
SRH15.7x7.5x28.5	15.7 ± 0.4	7.5 ± 0.3	28.5 ± 0.6	K5A	9	90	180
SRH15.88x8.0x28.5	15.88 ± 0.4	8.0 ± 0.3	28.5 ± 0.6	K5A		100	160
SRH16.0x4.3x17.5	16.0 ± 0.4	4.3 ± 0.3	17.5 ± 0.4	K5A		100	185
SRH16.0x8.0x16.0	16.0 ± 0.4	8.0 ± 0.3	16.0 ± 0.4	K5A		55	110
SRH16.0x9.0x17.0	16.0 ± 0.4	9.0 ± 0.3	17.0 ± 0.4	K5A	11	50	80
SRH16.0x9.0x28.0	16.0 ± 0.4	9.0 ± 0.3	28.0 ± 0.6	K5A	12	80	150
SRH17.07x8.76x25.4	17.07 ± 0.4	8.76 ± 0.3	25.4 ± 0.6	K5A		90	130
SRH17.2x7.0x28.5	17.2 ± 0.4	7.0 ± 0.3	28.5 ± 0.6	K5A		140	230
SRH17.5x7.0x25.4	17.5 ± 0.4	7.0 ± 0.3	25.4 ± 0.6	P2M		110	200
SRH17.5x9.5x28.5	17.5 ± 0.4	9.5 ± 0.3	28.5 ± 0.6	K5A	15	85	145
SRH17.5x9.5x35.0	17.5 ± 0.4	9.5 ± 0.4	35.0 ± 0.8	K5A		120	200
SRH17.5x10.5x24.0	17.5 ± 0.4	10.5 ± 0.4	24.0 ± 0.6	K5A		85	130
SRH17.5x10.5x28.5	17.5 ± 0.4	10.5 ± 0.4	28.5 ± 0.6	K5A		90	150
SRH17.5x10.0x28.5	17.5 ± 0.4	10.0 ± 0.4	28.5 ± 0.6	K5A		100	240
SRH17.5x11.0x28.5	17.5 ± 0.4	11.0 ± 0.4	28.5 ± 0.6	K5A	16	80	130
SRH18.0x10.5x18.0	18.0 ± 0.5	10.5 ± 0.4	18.0 ± 0.6	K5A		45	90
SRH18.2x9.7x28.2	18.2 ± 0.5	9.7 ± 0.3	28.2 ± 0.6	K5A		133	250
SRH18.7x10.2x28.5	18.7 ± 0.5	10.2 ± 0.4	28.5 ± 0.6	K5A	18	70	130
SRH19.0x13.0x29.0	19.0 ± 0.5	13.0 ± 0.4	29.0 ± 0.6	K5A		60	110
SRH19.2x11.6x28.6	19.2 ± 0.5	11.6 ± 0.4	28.6 ± 0.6	K5A		76	118
SRH20.7x12.0x28.5	20.7 ± 0.6	12.0 ± 0.4	28.5 ± 0.6	K5A	19	85	160
SRH25.9x12.3x29.0	25.9 ± 0.6	12.3 ± 0.4	29.0 ± 0.6	K5A		90	180
SRH25.9x0.6x29.0	25.9 ± 0.6	0.6 ± 0.4	29.0 ± 0.6	K5A		120	240
SRH26.0x13.0x28.5	26.0 ± 0.6	13.0 ± 0.4	28.5 ± 0.6	K5A	23	116	180
SRH26.0x14.0x28.5	26.0 ± 0.6	14.0 ± 0.4	28.5 ± 0.6	K5A	24	90	180
SRH28.0x14.0x28.0	28.0 ± 0.6	14.0 ± 0.4	28.0 ± 0.6	K5A	25	110	180
SRH28.0x16.0x28.5	28.0 ± 0.6	16.0 ± 0.4	28.5 ± 0.6	K5A		110	220

Ferrite Bead – SDRH Series

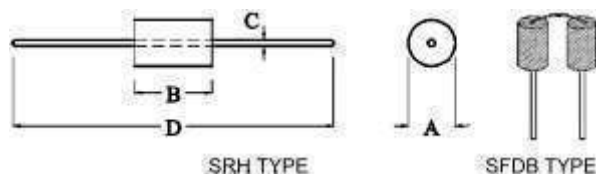
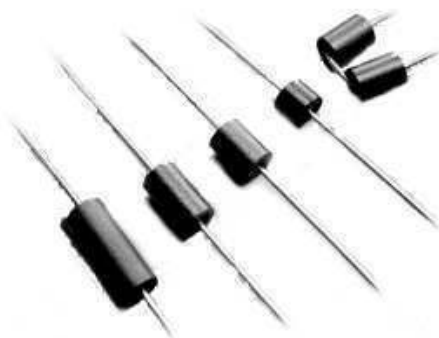

Features

- Decreased DCR resistance
- Increased current capacity
- 25% impedance tolerance

Package

SDRH Series	SFDB Series
5000pcs. / Reel	1000pcs. / Bag
1000pcs. / Box	4000pcs. / Box

Ordering Information

K5A SDRH – 2.5x3.0x0.8

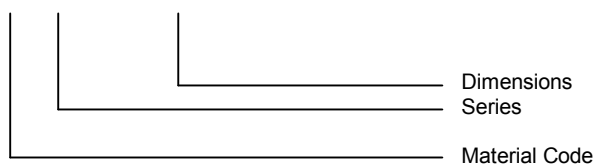

Characteristics

Part No.	Impedance (Ω)		Mat.Code	Dimensions (mm)			
	25MHz	100MHz		A	B	C	D
SDRH2.5x3.0x0.8	25	50	K5A	2.5	3.0	0.65	62.5
SDRH3.5x3.0x0.8	30	50	K5A	3.5	3.0	0.65	62.5
SDRH3.5x4.5x0.8	30	60	K5A	3.5	4.5	0.65	62.5
SDRH3.5x4.7x0.8	35	60	K5A	3.5	4.7	0.65	62.5
SDRH3.5x4.7x0.8	50	60	NP22D	3.5	4.7	0.65	62.5
SDRH3.5x5.0x0.8	40	70	K5A	3.5	5.0	0.65	62.5
SDRH3.5x6.0x0.8	50	75	K5A	3.5	6.0	0.65	62.5
SDRH3.5x6.0x0.8	40	90	C8	3.5	6.0	0.65	62.5
SDRH3.5x6.0x0.8	60	75	NP22D	3.5	6.0	0.65	62.5
SDRH3.5x7.5x0.8	60	90	K5A	3.5	7.5	0.65	62.5
SDRH3.5x8.0x0.8	60	100	K5A	3.5	8.0	0.65	62.5
SDRH3.5x8.0x0.8	60	130	C8	3.5	8.0	0.65	62.5
SDRH3.5x9.0x0.8	80	120	K5A	3.5	9.0	0.65	62.5
SDRH3.5x9.0x0.8	75	150	C8	3.5	9.0	0.65	62.5
SFDB3.5x6.0x0.8	90	150	K5A	3.5	6.0	0.65	62.5
SFDB3.5x4.7x0.8	75	135	K5A	3.5	4.7	0.65	62.5

Customer designs available.

Chip Bead – SCB Series

SCHMID-M

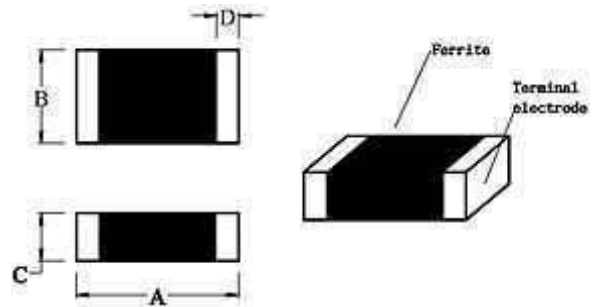
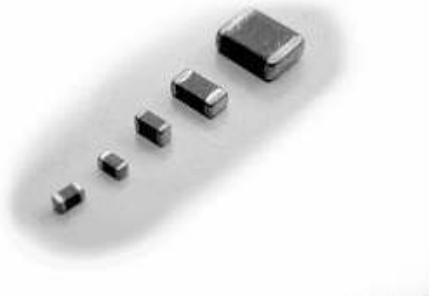

Features

- SCB series offers full specification for your needs. Wide impedance characteristic and many sizes for easy design-in
- SCB-C series is used in high-speed single line applications
- SCB-A series for large current
- This inductor generates high impedance which at high frequency mainly consists of a resistance element

Dimensions

Part No.	A	B	C	D
SCB100505 (0402)	1.0±0.1	0.5±0.1	0.5±0.1	0.1Min.
SCB160808 (0603)	1.6±0.2	0.8±0.2	0.8±0.2	0.3±0.2
SCB201209 (0805)	2.0±0.2	1.2±0.2	0.9±0.2	0.5±0.3
SCB321611 (1206)	3.2±0.2	1.6±0.2	1.1±0.2	0.5±0.3
SCB321616 (1206)	3.2±0.2	1.6±0.2	1.6±0.2	0.5±0.3
SCB322513 (1210)	3.2±0.2	2.5±0.2	1.3±0.2	0.5±0.3
SCB451616 (1806)	4.5±0.2	1.6±0.2	1.6±0.2	0.5±0.3
SCB453215 (1812)	4.5±0.2	3.2±0.2	1.5±0.2	0.5±0.3

Ordering Information

SCB 201209 □-121

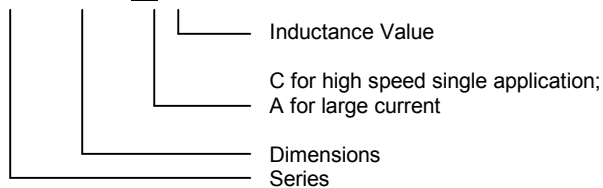

SIZE	100505	160808	201209	321611
QTY /REEL	10000pcs.	4000pcs.	4000pcs.	3000pcs.
	321616	322513	451616	453215
	2000pcs.	2000pcs.	2000pcs.	1000pcs.

Characteristics

Part No.	Impedance (Ω)	Test Frequency (MHz)	RDC (Ω)	IDC (mA)
SCB100505-300	30 ± 25%	100	0.30	500
SCB100505-600	60 ± 25%	100	0.40	200
SCB100505-121	120 ± 25%	100	0.50	200
SCB100505-221	220 ± 25%	100	0.70	100
SCB100505-301	300 ± 25%	100	0.80	100
SCB100505-451	450 ± 25%	100	0.90	100
SCB100505-601	600 ± 25%	100	1.00	100
SCB160808-090	9 ± 25%	100	0.20	500
SCB160808-300	30 ± 25%	100	0.20	400
SCB160808-600	60 ± 25%	100	0.20	300
SCB160808-800	80 ± 25%	100	0.20	300
SCB160808-121	120 ± 25%	100	0.20	200
SCB160808-221	220 ± 25%	100	0.20	200
SCB160808-301	300 ± 25%	100	0.35	200
SCB160808-451	450 ± 25%	100	0.40	200
SCB160808-601	600 ± 25%	100	0.45	200
SCB160808-102	1000 ± 25%	100	0.60	100
SCB201209-110	11 ± 25%	100	0.15	600
SCB201209-320	32 ± 25%	100	0.15	400
SCB201209-800	80 ± 25%	100	0.15	300
SCB201209-121	120 ± 25%	100	0.25	300
SCB201209-151	150 ± 25%	100	0.25	300
SCB201209-221	220 ± 25%	100	0.30	200
SCB201209-301	300 ± 25%	100	0.30	200
SCB201209-501	500 ± 25%	100	0.30	200
SCB201209-601	600 ± 25%	100	0.35	200
SCB201209-102	1000 ± 25%	100	0.45	200
SCB321611-310	31 ± 25%	100	0.20	500



Part No.	Impedance (Ω)	Test Frequency (MHz)	RDC (Ω)	IDC (mA)
SCB321611-600	60 \pm 25%	100	0.30	400
SCB321611-900	90 \pm 25%	100	0.30	300
SCB321611-151	150 \pm 25%	100	0.30	300
SCB321611-301	300 \pm 25%	100	0.30	300
SCB321611-601	600 \pm 25%	100	0.30	200
SCB321611-122	1200 \pm 25%	50	0.50	100
SCB321611-202	2000 \pm 25%	30	0.60	100
SCB321616-600	60 \pm 25%	100	0.30	400
SCB322513-600	60 \pm 25%	30	0.30	400
SCB322513-900	90 \pm 25%	30	0.30	300
SCB451616-600	60 \pm 25%	30	0.10	500
SCB451616-151	150 \pm 25%	100	0.30	300
SCB453215-131	130 \pm 25%	100	0.30	300

SCB100505-121

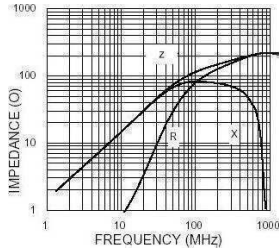

SCB100505-221

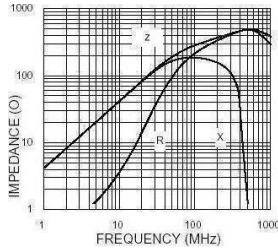

SCB100505-300

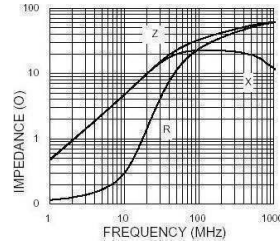

SCB100505-301

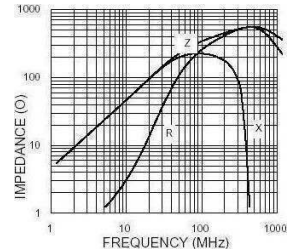

SCB100505-451

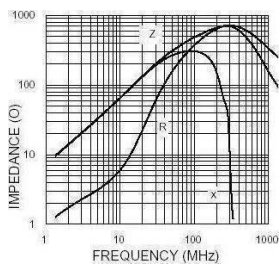

SCB100505-600

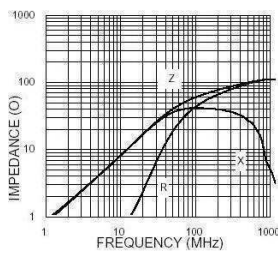

SCB100505-601

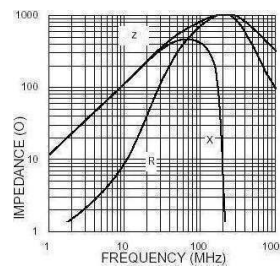

SCB160808-090

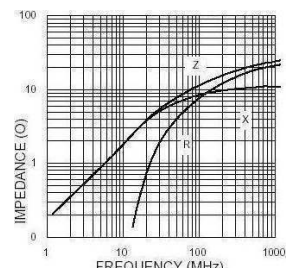

SCB160808-300

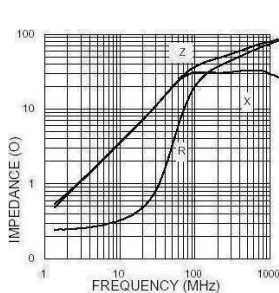



Characteristic-SCB-A

Part No.	Impedance (Ω)	Test Frequency (MHz)	RDC (Ω)	IDC (mA)
SCB160808A-300/3	30 ± 25%	100	0.030	3000
SCB160808A-600/3	60 ± 25%	100	0.040	3000
SCB160808A-121/2.5	120 ± 25%	100	0.100	2500
SCB160808A-301/2	300 ± 25%	100	0.150	2000
SCB160808A-601/1	600 ± 25%	100	0.200	1000
SCB201209A-110/6	11 ± 25%	100	0.010	6000
SCB201209A-170/6	17 ± 25%	100	0.025	3000
SCB201209A-220/6	22 ± 25%	100	0.025	3000
SCB201209A-300/6	30 ± 25%	100	0.025	3000
SCB201209A-121/6	120 ± 25%	100	0.060	3000
SCB201209A-301/6	300 ± 25%	100	0.100	2000
SCB201209A-601/6	600 ± 25%	100	0.150	2000
SCB321611A-260/3	26 ± 25%	100	0.010	6000
SCB321611A-310/6	31 ± 25%	100	0.010	6000
SCB321611A-500/3	50 ± 25%	100	0.025	3000
SCB321611A-121/3	120 ± 25%	100	0.040	3000
SCB 3221611A-301/2.5	300 ± 25%	100	0.050	2500
SCB321611A-601/2	600 ± 25%	100	0.100	2000
SCB322513A-300/3	30 ± 25%	100	0.050	3000
SCB322513A-520/3	52 ± 25%	100	0.050	3000
SCB322513A-650/3	65 ± 25%	100	0.030	3000
SCB451616A-600/6	60 ± 25%	100	0.010	6000
SCB451616A-750/3	75 ± 25%	100	0.025	3000
SCB451616A-800/3	80 ± 25%	100	0.050	3000
SCB453215A-700/6	70 ± 25%	100	0.030	6000
SCB453215A-121/3	120 ± 25%	100	0.050	3000

SCB321611A-121/3

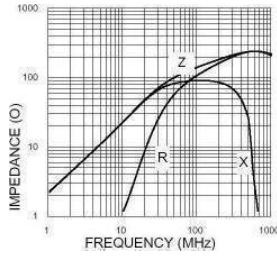

SCB321611A-260/3

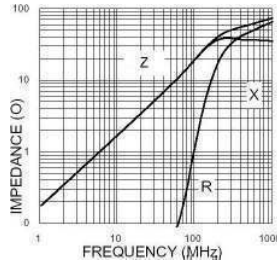

SCB321611A-301/2.5

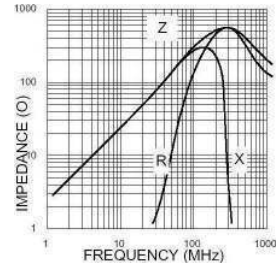

SCB321611A-310/6

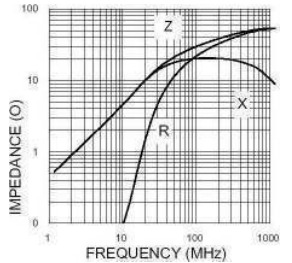

SCB321611A-500/3

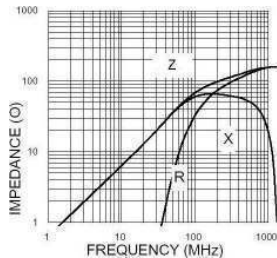

SCB321611A-601/2

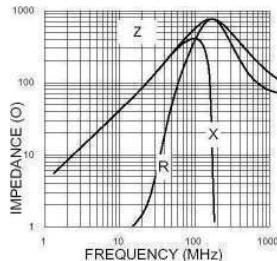

SCB322513A-520/3

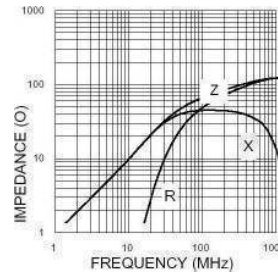

SCB322513A-650/3

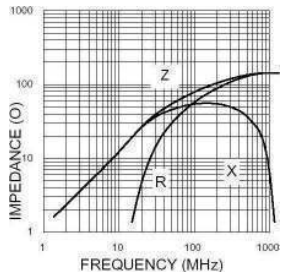

SCB322516A-300/3

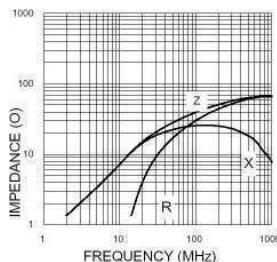

SCB451616A-600/6

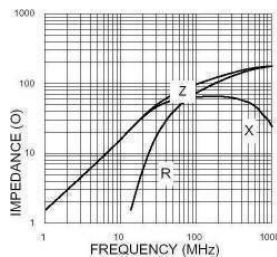

SCB451616A-750/3

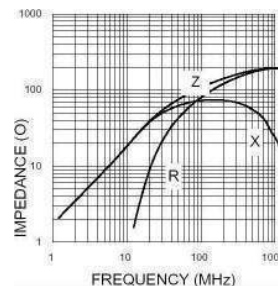

SCB451616A-800/3

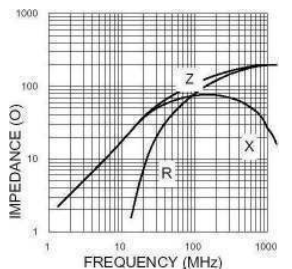



Characteristic-SCB-C

Part No.	Impedance (Ω)	Test Frequency (MHz)	RDC (Ω)	IDC (mA)
SCB100505C-300	30 ± 25%	100	0.40	200
SCB100505C-600	60 ± 25%	100	0.50	200
SCB100505C-121	120 ± 25%	100	0.70	100
SCB100505C-221	220 ± 25%	100	0.90	100
SCB100505C-301	300 ± 25%	100	1.00	100
SCB160808C-600	60 ± 25%	100	0.30	300
SCB160808C-800	80 ± 25%	100	0.30	200
SCB160808C-121	120 ± 25%	100	0.30	200
SCB160808C-221	220 ± 25%	100	0.40	200
SCB160808C-301	300 ± 25%	100	0.45	200
SCB160808C-601	600 ± 25%	100	0.65	200
SCB160808C-102	1000 ± 25%	100	0.80	50
SCB201209C-400	40 ± 25%	100	0.20	300
SCB201209C-800	80 ± 25%	100	0.20	300
SCB201209C-121	120 ± 25%	100	0.25	200
SCB201209C-221	220 ± 25%	100	0.35	200
SCB201209C-301	300 ± 25%	100	0.40	200
SCB201209C-601	600 ± 25%	100	0.50	200
SCB201209C-102	1000 ± 25%	100	0.60	200
SCB321611C-190	19 ± 25%	30	0.20	500
SCB321611C-151	150 ± 25%	100	0.30	300
SCB321611C-301	300 ± 25%	100	0.30	300
SCB321611C-601	600 ± 25%	100	0.30	200

SCB100505C-121

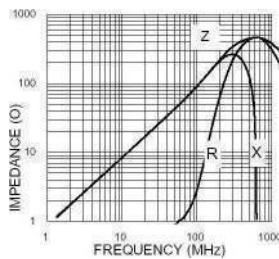

SCB100505C-221

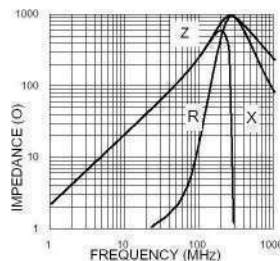

SCB100505C-300

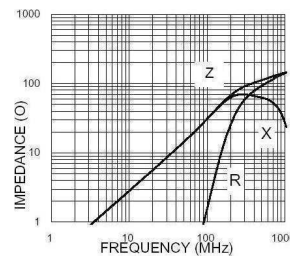

SCB100505C-301

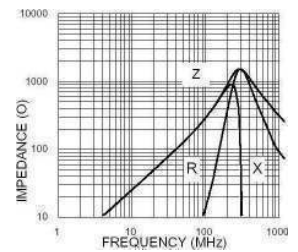

SCB100505C-600

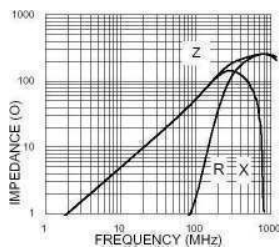

SCB160808C-102

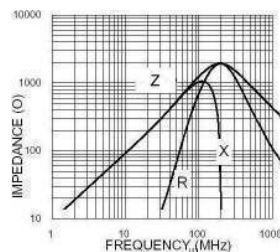

SCB160808C-121

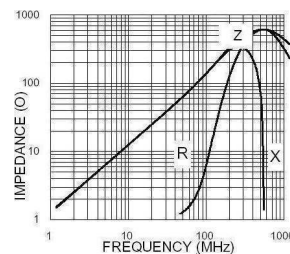

SCB160808C-221

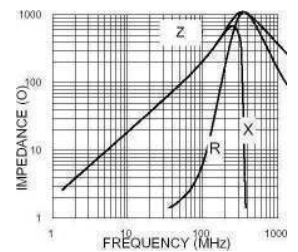

SCB160808C-301

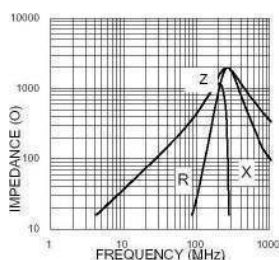

SCB160808C-600

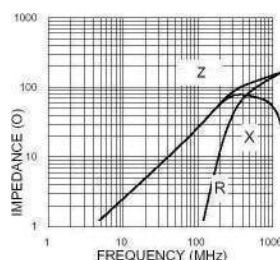

SCB160808C-601

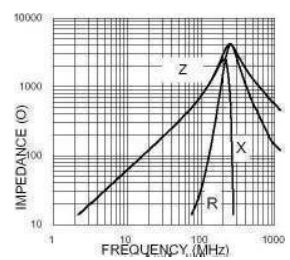

SCB160808C-800

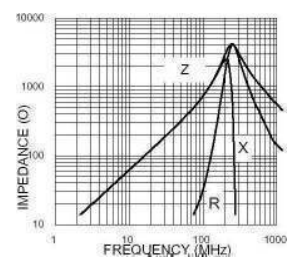



SCB201209C-102

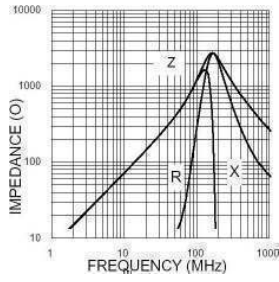

SCB201209C-121

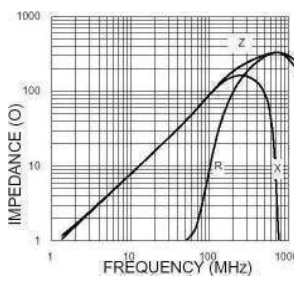

SCB201209C-221

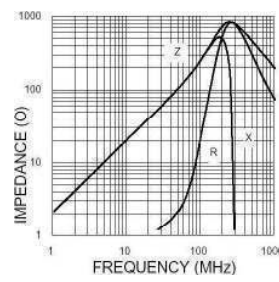

SCB201209C-301

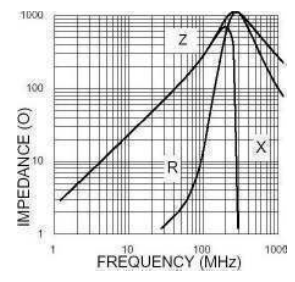

SCB201209C-400

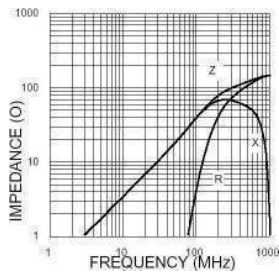

SCB201209C-601

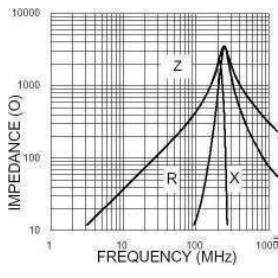

SCB201209C-800

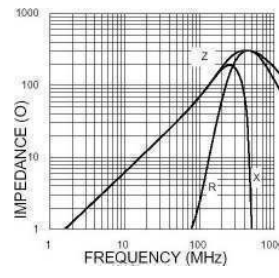

SCB321611C-151

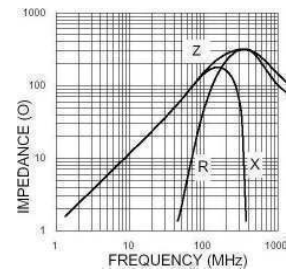

SCB321611C-190

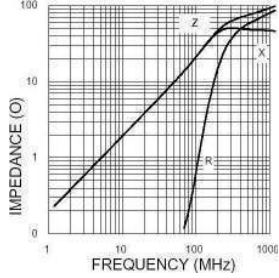

SCB321611C-301

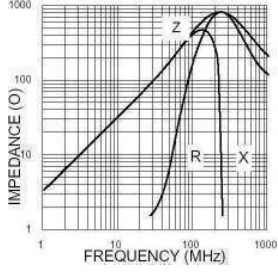

SCB321611C-601

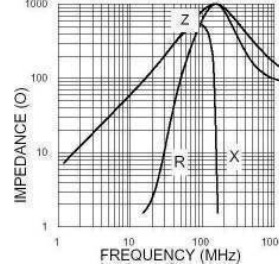

SMD Chip Bead Array – SCA Series

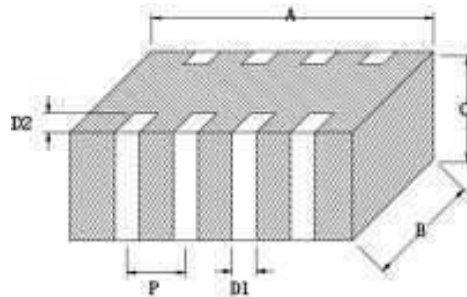
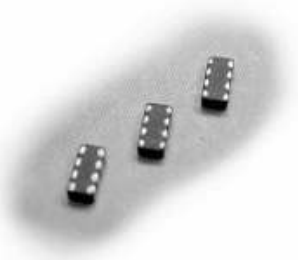

Features

- SCA series consists of 4 circuits
- SCA series is suitable for EMI suppression in small digital equipment
- Excellent solderability and resistance to soldering heat
- Closed magnetic circuit avoids crosstalk

Dimensions

Part No.	A	B	C	D	D1
SCA3216	3.2 ± 0.2	1.6 ± 0.2	0.8 ± 0.2	0.4 ± 0.2	0.4 ± 0.2
	D2	P			
	0.3 ± 0.2	0.8 ± 0.1			
QTY/REEL	3000pcs.				

Ordering Information

SCA 3216 K 4-121

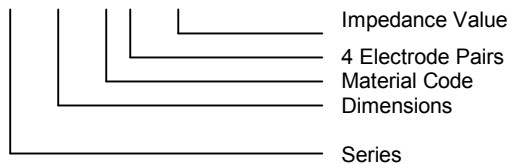

Characteristics

Part No.	Impedance (Ω)	Test Frequency (MHz)	DC Resistance (Ω)Max.	Rated Current (mA)Max.
SCA3216K4-300	$30 \pm 25\%$	100	0.10	200
SCA3216K4-600	$60 \pm 25\%$	100	0.25	200
SCA3216K4-121	$120 \pm 25\%$	100	0.30	150
SCA3216K4-221	$220 \pm 25\%$	100	0.30	150
SCA3216K4-301	$300 \pm 25\%$	100	0.40	150
SCA3216K4-601	$600 \pm 25\%$	100	0.50	100
SCA3216K4-102	$1000 \pm 25\%$	100	0.70	50
SCA3216M4-121	$120 \pm 25\%$	100	0.40	150
SCA3216M4-221	$220 \pm 25\%$	100	0.45	150
SCA3216M4-301	$300 \pm 25\%$	100	0.50	150
SCA3216M4-471	$470 \pm 25\%$	100	0.55	100
SCA3216M4-601	$600 \pm 25\%$	100	0.65	100



SCA3216K4-121

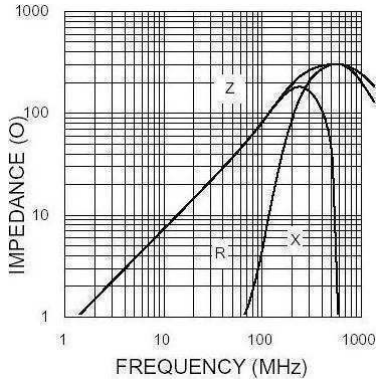

SCA3216K4-102

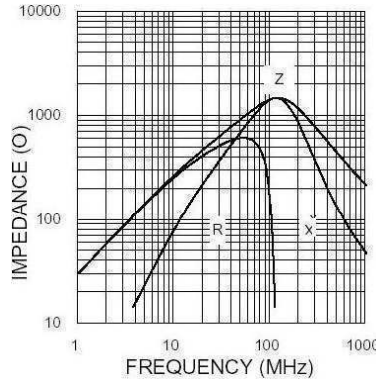

SCA3216M4-121

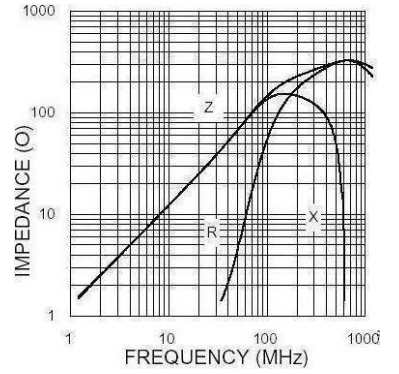

SCA3216K4-301

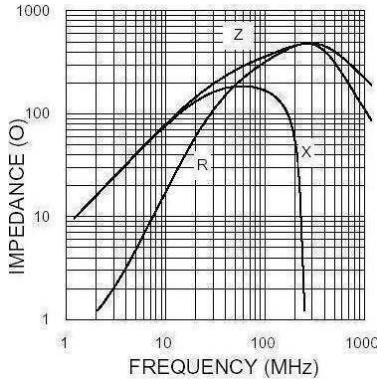

SCA3216K4-600

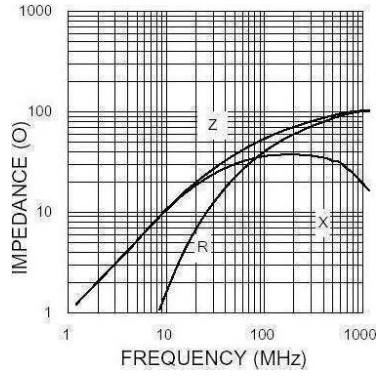

SCA3216K4-601

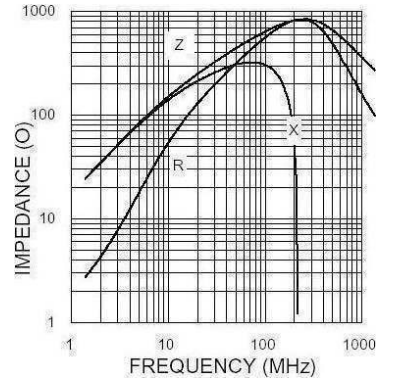

SCA3216M4-221

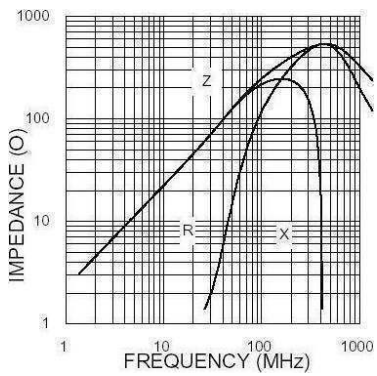

SCA3216M4301

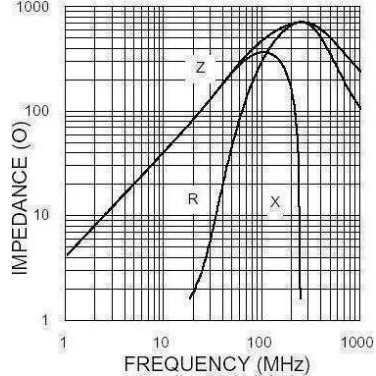

SCA3216M4-47

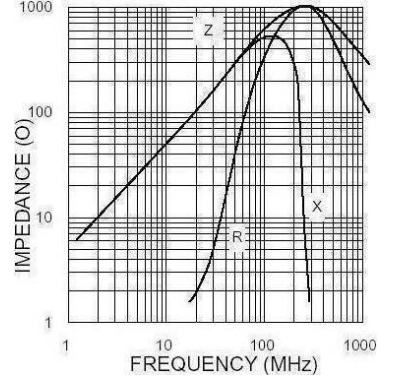

SCA3216K4-300

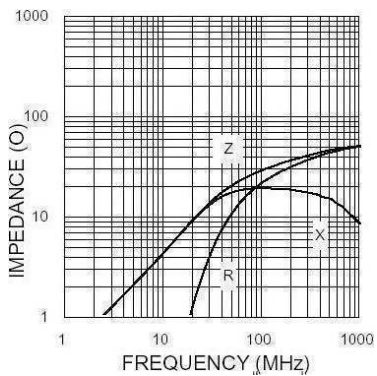

SCA3216K4-221

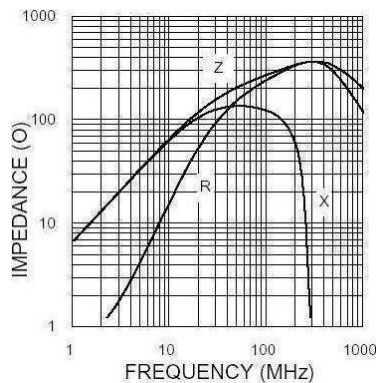

SCA3216M4-601

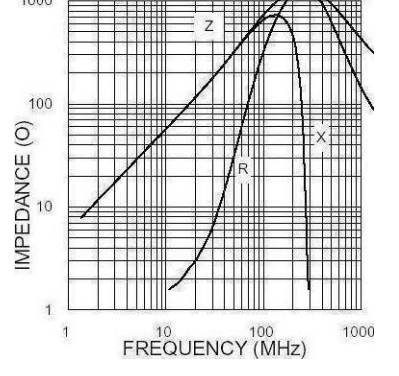



Ferrite Bead – SFB Series

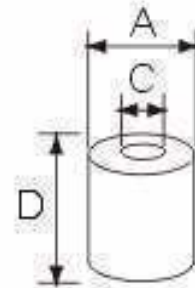

Features

- Employ high-performance ferrites with superior frequency characteristics
- prevents intrusion and radiation of unnecessary signals into the clock pulse oscillation section. Prevents spike noise

Package

- R – Reel 5000pcs./Reel
- M – Box 2000pcs./Box
- Z – Ammo Pack
- B – Bulk

Ordering Information

SFBS 13 – 350860 – T5 - R

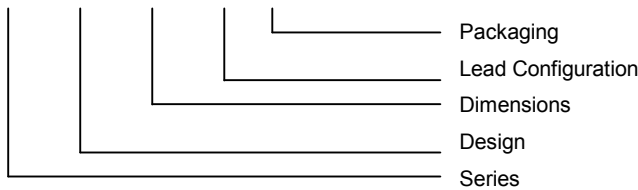

Characteristics

Part No.	Lead Configuration	Impedance (Ω) min		Curve
		25MHz	100MHz	
SFBS13-250845	T5,T2,VT, RT,UT, VB,RB,UB,ST FD,FE,FF	32	50	1
SFBS13-350830		25	45	2
SFBS13-350847		35	60	3
SFBS13-350860		45	72	4
SFBS13-350875		60	120	5
SFBS13-350880		75	123	6
SFBS13-350883		62	125	7
SFBS13-350890		50	93	8
SFBD13-350847	WT,WB	70	110	9
SFBD13-350860		90	150	10
SFBD13-350875		135	218	11
SFBD13-350883		124	240	12
SFBD13-350883		108	235	13
SFBD13-350890		150	250	14
SFBR13-235575	ST,SB	80	150	15

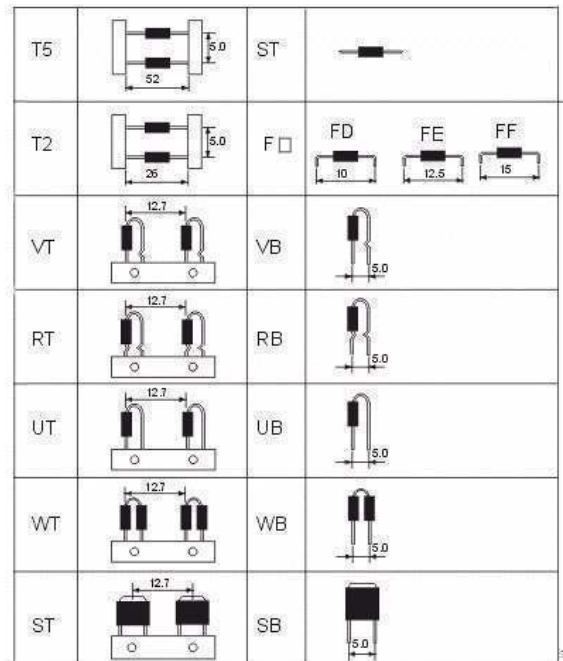

Dimensions

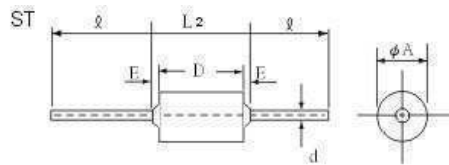

Part No.	A	D	E	d	l
SFBS13-250845-ST	2.5 ± 0.15	4.5 ± 0.3	2.0 max.	0.65 ± 0.05	18.0 min.
SFBS13-350847-ST	3.5 ± 0.15	4.7 ± 0.3	2.0 max.		
SFBS13-350860-ST	3.5 ± 0.15	6.0 ± 0.3	2.5 max.		
SFBS13-350890-ST	3.5 ± 0.15	9.0 ± 0.4	2.5 max.		

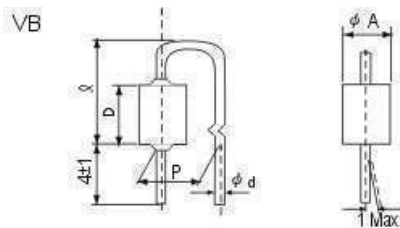

Part No.	A	D	P	d	l
SFBS13-350847-VB	3.5 ± 0.15	4.7 ± 0.3	5.0 ± 1.0	0.6 ± 0.05	9.0 max.

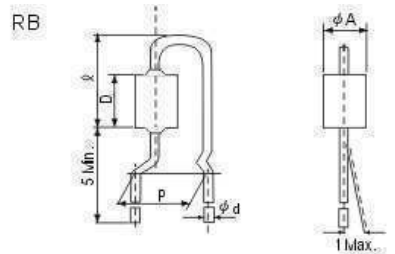

Part No.	A	D	P	d	l
SFBS13-350847-RB	3.5 ± 0.15	4.7 ± 0.3	5.0 ± 1.0	0.65 ± 0.05	12.5 max.
SFBS13-350860-RB	3.5 ± 0.15	6.0 ± 0.3	5.0 ± 1.0		12.5 max.
SFBS13-350890-RB	3.5 ± 0.15	9.0 ± 0.3	5.0 ± 1.0		16.0 max.

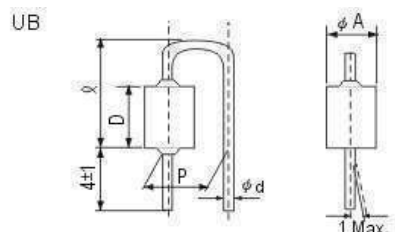

Part No.	A	D	P	d	l
SFBS13-250845-UB	2.5 ± 0.15	4.5 ± 0.3	5.0 ± 1.0	0.65 ± 0.05	9.0 max.
SFBS13-350847-UB	3.5 ± 0.15	4.7 ± 0.3	5.0 ± 1.0		9.0 max.

FD,FE,FF

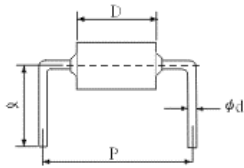

Part No.	A	D	P	d	l
SFBS13-250845-FD	2.5 ± 0.15	4.5 ± 0.3	10.0 ± 1.0	0.65 ± 0.05	7.0 ± 2.0
SFBS13-350847-FD	3.5 ± 0.15	4.7 ± 0.3	10.0 ± 1.0		7.5 ± 2.0
SFBS13-350860-FD	3.5 ± 0.15	6.0 ± 0.3	10.0 ± 1.0		7.5 ± 2.0
SFBS13-250845-FE	2.5 ± 0.15	4.5 ± 0.3	12.5 ± 0.5		7.0 ± 2.0
SFBS13-350847-FE	3.5 ± 0.15	4.7 ± 0.3	12.5 ± 0.5		7.5 ± 2.0
SFBS13-350860-FE	3.5 ± 0.15	6.0 ± 0.3	12.5 ± 0.5		7.5 ± 2.0
SFBS13-350890-FE	3.5 ± 0.15	9.0 ± 0.4	12.5 ± 0.5		7.5 ± 2.0
SFBS13-250845-FF	2.5 ± 0.15	4.5 ± 0.3	15.0 ± 0.1		7.0 ± 2.0
SFBS13-350847-FF	3.5 ± 0.15	4.7 ± 0.3	15.0 ± 0.1		7.5 ± 2.0
SFBS13-350860-FF	3.5 ± 0.15	6.0 ± 0.3	15.0 ± 0.1		7.5 ± 2.0
SFBS13-350890-FF	3.5 ± 0.15	9.0 ± 0.4	15.0 ± 0.1		7.5 ± 2.0

WB

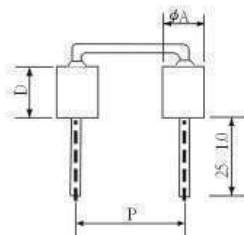

Part No.	A	D	P	d
SFBD13-350847-WB	3.5 ± 0.15	4.7 ± 0.3	$5.0 +0.8 -0.3$	0.65 ± 0.03
SFBD13-350860-WB	3.5 ± 0.15	6.0 ± 0.3	$5.0 +0.8 -0.3$	
SFBD13-350875-WB	3.5 ± 0.15	7.5 ± 0.3	$5.0 +0.8 -0.3$	
SFBD13-350883-WB	3.5 ± 0.15	8.3 ± 0.3	$5.0 +0.8 -0.3$	
SFBD13-350883-WB	3.5 ± 0.15	8.3 ± 0.3	$5.0 +0.8 -0.3$	
SFBD13-350890-WB	3.5 ± 0.15	9.0 ± 0.4	$5.0 +0.8 -0.3$	

SB

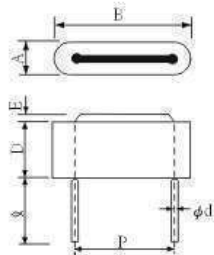

Part No.	A	B	D	E	P	d	l
SFBR13-235575-SB	2.5 max.	7.5 ± 0.5	5.5	1.5 max.	$5.0 +1.0 -0.5$	0.65 ± 0.03	$5.0 +1.0 -2.0$

SMD Common Mode Bead – SSMB Series

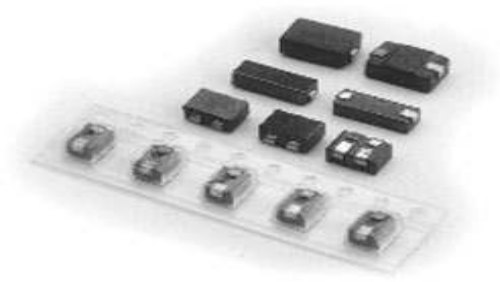

Shapes

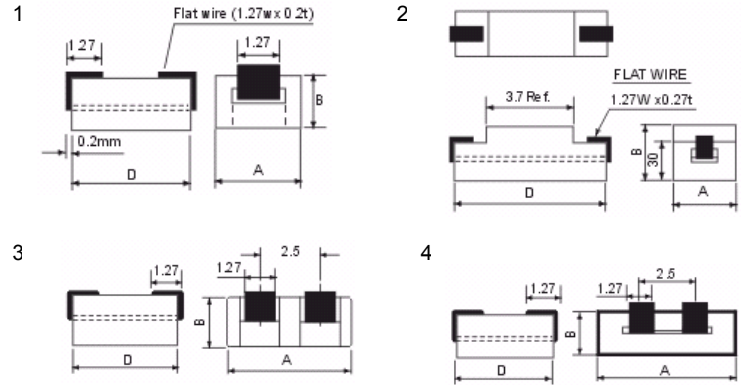

Features

- Supplied taped and reeled per EIA standard
- Applications: Computer disk drive and PC board to filter the EMI from outside source. Car radio, mobile phone.

Ordering Information

SSMB 03-562545 -2H



Characteristics

Part No.	Shape	A	B	D	Impedance (Ω) min		Curve
					25MHz	100MHz	
SSMB13-302540	1	3.18	2.67	4.0 ± 0.25	24	36	1
SSMB13-302585	1	3.18	2.67	8.5 ± 0.25	48	72	2
SSMB03-472976	2	$5.0 +0 -0.5$	$3.45 +0 -0.3$	7.6 ± 0.1	60	90	3
SSMB13-472976	2	$5.0 +0 -0.5$	$3.45 +0 -0.3$	7.6 ± 0.1	58	80	4
SSMB13-562540-2H	3	5.6 ± 0.2	2.5 ± 0.2	4.0 ± 0.25	22	35	5
SSMB03-562545-2H	3	5.6 ± 0.2	2.5 ± 0.2	4.5 ± 0.25	24	36	6
SSMB04-562545-2H	3	5.6 ± 0.2	2.5 ± 0.2	4.5 ± 0.25	18	36	7
SSMB50-562545-2H	3	5.6 ± 0.2	2.5 ± 0.2	4.5 ± 0.25	24	32	8
SSMB47-562585-2H	3	5.6 ± 0.2	2.5 ± 0.2	8.5 ± 0.25	24	35	9
SSMB47-572685-1H2W	4	$5.7 +0.1 -0.5$	$2.6 +0.1 -0.2$	8.47 ± 0.1	48	70	10
SSMB47-562540-2H	3	6.0 ± 0.2	2.5 ± 0.2	4.0 ± 0.25	24	35	11



S.M. Bead Array – SSMA Series

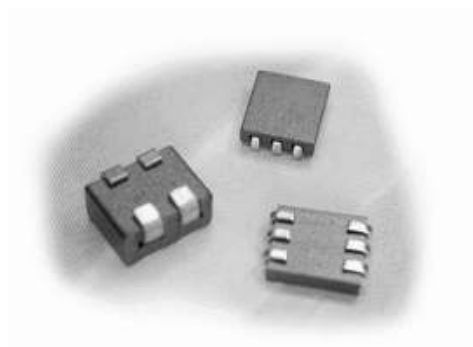

Features

- high resistance to heat and humidity and accurate dimensions for automatically surface mounting

Ordering Information

SSMA 455625 -500

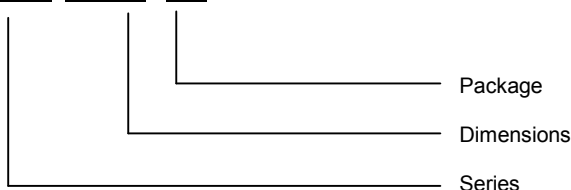

Dimensions

Part No.	Impedance (Ω)		Dimensions (mm)				
	25 MHz	100 MHz	A	B	C	D	E
SSMA455625	23 Ref.	35 Ref.	4.5 ± 0.20	5.6 ± 0.20	3.0 ± 0.15	1.40 ± 0.15	2.54 ± 0.20
SSMA604515	23 Ref.	50 Ref.	5.6 ± 0.30	5.0 Max.	1.5 ± 0.20	1.40 ± 0.15	1.30 ± 0.20

Package

SIZE	SSMA455625	SSMA455625	SSMA604515
QTY/REEL	500pcs.	2000pcs.	1000pcs.
REEL SIZE	7"	13"	7"

Characteristics

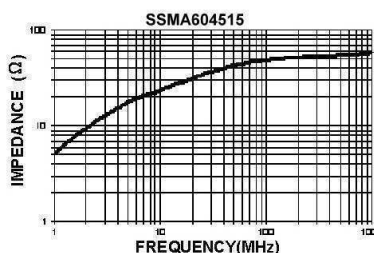
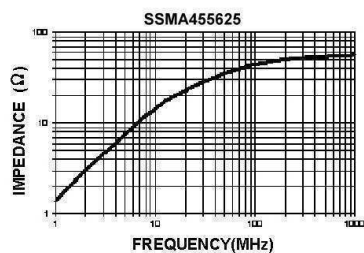

5-Hole Ferrite Bead – SR5H Series

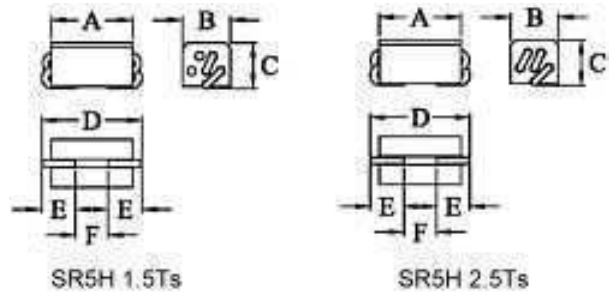

Features

- SR5H series is SMD version of SR6H

Dimensions

Core	A	B	C	D	E	F
SR5H	8.5 ± 0.25	5.0 ± 0.25	4.6 ± 0.20	11 Max.	3 ± 0.10	2 Min.

Ordering Information

SR5H 1.5Ts



Package

Type	SR5H1.5Ts	SR5H2.5Ts
Bag	250pcs.	250pcs.
Box	1500pcs.	1500pcs.

Series

Part No.	Turns (Ts)	RDC (mΩ)	Typical Impedance (Ω)		
			10MHz	50MHz	100MHz
SR5H1.5Ts	1.5	7.5	230 Ref.	400 Ref.	430 Ref.
SR5H2.5Ts	2.5	7.5	300 Ref.	625 Ref.	600 Ref.

SR5H 1.5Ts

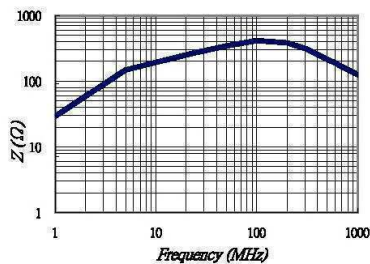

SR5H 2.5Ts

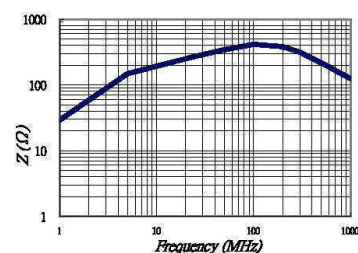



6-Hole Ferrite Bead – SR6H Series

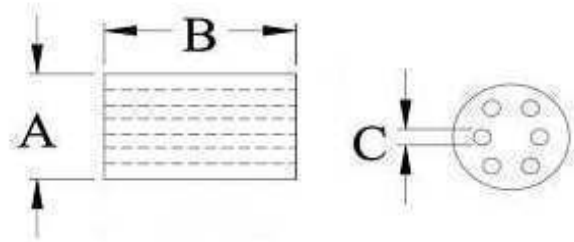
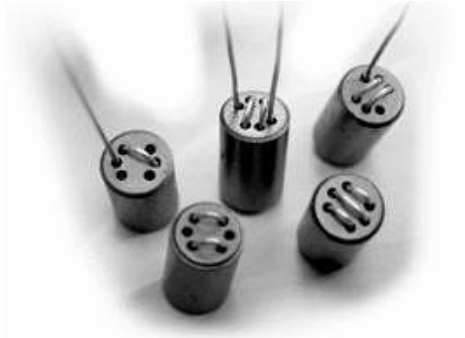

Features

- Compact, medium current, high impedance → EMI suppression component
- Wide Band Coke used in PC products to filter EMI

Ordering Information

SR6H – 1.5Ts

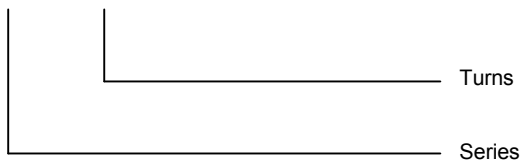

Dimensions

Core	A	B	C	D			
SR6H 6x10	6.0 ± 0.25	10.0 ± 0.30	0.9 ± 0.15	0.5 ± 0.05			
Turns	1.5Ts	2Ts	2.5Ts	3Ts	1.5Ts X2	2.5Ts U	3Ts U
Package	Bulk: 250pcs. / Bag; 1 Box = 6 Bags (1500pcs.)						

Shapes

1.5Ts

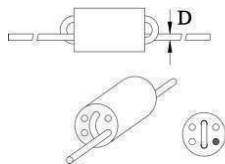

2Ts

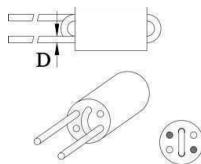

2.5Ts

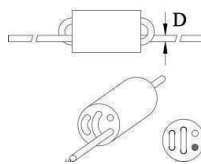

3Ts

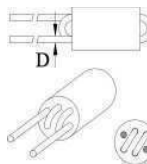

1.5Ts x2

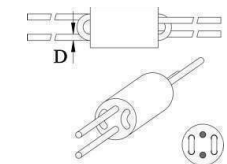

2.5Ts U

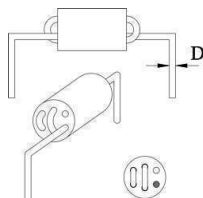

3Ts U

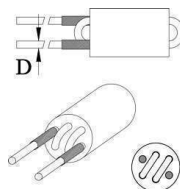

6-Hole Ferrite Bead – SR6H Series

Part No.	Turns (Ts)	Typical Impedance (Ω)		
		10MHz (min)	25MHz (min)	100MHz (min)
SR6H1.0Ts	1.0	58	182	233
SR6H1.5Ts	1.5	170	320	375
SR6H2.0Ts	2.0	240	520	480
SR6H2.5Ts	2.5	320	680	580
SR6H2.5Ts	2.5	400	680	580
SR6H3.0Ts	3.0	400	800	550
SR6H1.5Tsx2	1.5x2	170	320	375

Characteristics

A6 SR6H 2.5Ts

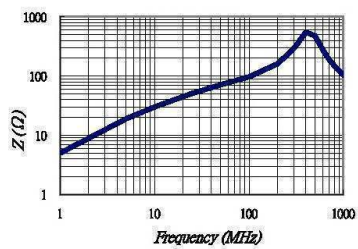

K5B SR6H 1.0Ts

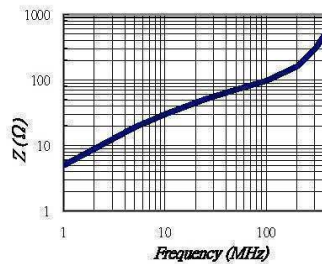

K5B SR6H 1.5Ts

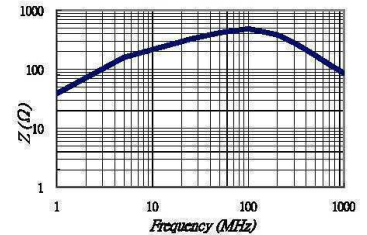

K5B SR6H 1.5Tsx2

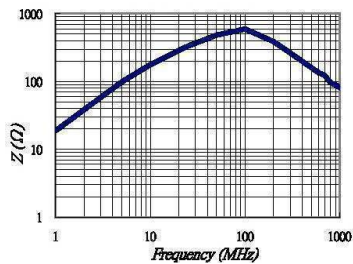

K5B SR6H 2.0Ts

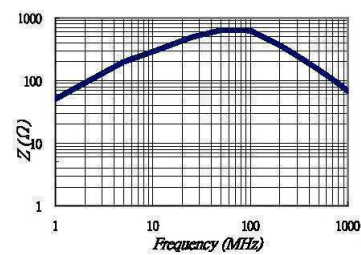

K5B SR6H 2.5Ts

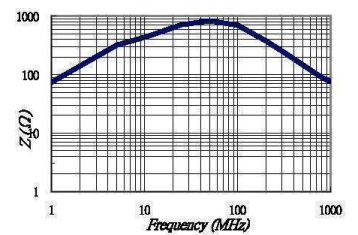

K5B SR6H 3.0Ts

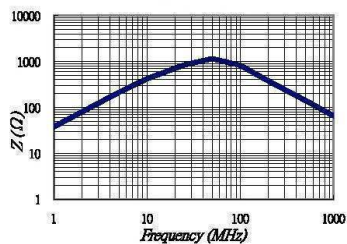

SMD Multilayer Chip Inductor – SCI Series

SCHMID-M

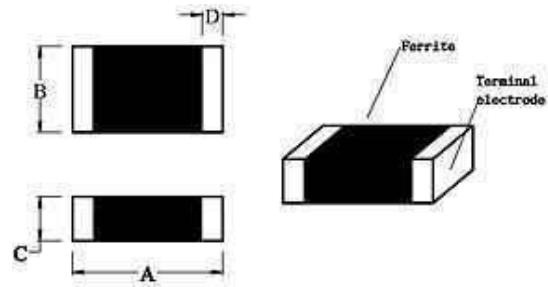
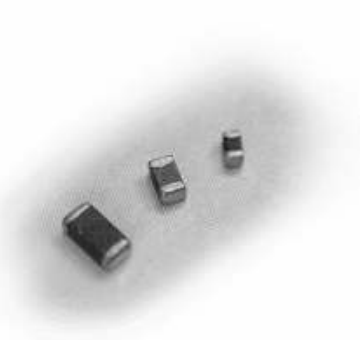

Features

- SCI Series provides an effective solution for dense packed PCB designs
- Excellent solderability and high heat resistance for either flow or reflow soldering
- Closed magnetic circuit avoids crosstalk

Ordering Information

SCI 1608-4R7 K

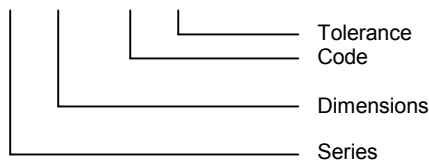

Dimensions

Part No.	A	B	C	D
SCI1608 (0603)	1.6 ± 0.2	0.8 ± 0.2	0.80 ± 0.2	0.3 ± 0.2
SCI2012 (0805) 47N-2R2	2.0 ± 0.2	1.2 ± 0.2	0.90 ± 0.2	0.5 ± 0.3
SCI2012 (0805) 2R7-150	2.0 ± 0.2	1.2 ± 0.2	1.20 ± 0.2	0.5 ± 0.3
SCI2012 (0805) 180-470	2.0 ± 0.2	1.2 ± 0.2	1.25 ± 0.2	0.5 ± 0.3
SCI3216 (1206)	3.2 ± 0.2	1.6 ± 0.2	1.10 ± 0.2	0.3 ± 0.3

SIZE	SCI1608	SCI2012 (47N-2R2)	SCI2012 (2R7-470)	SCI3216
QTY/REE L	4000pcs.	4000pcs.	2000pcs.	3000pcs.

Characteristics-SCI1608

All Series: Tolerance: K = ± 10%; M = ± 20%

Part No.	Inductance (µH)	Tolerance	Q (min)	Test Frequency (MHz)	SRF Min. (MHz)	RDC Max. (Ω)	IDC Max. (mA)
SCI1608-47NM	0.047	M	10	50	260	0.30	50
SCI1608-68NM	0.068	M	10	50	250	0.30	50
SCI1608-R10 □	0.100	K / M	15	25	240	0.50	50
SCI1608-R12 □	0.120	K / M	15	25	205	0.50	50
SCI1608-R15 □	0.150	K / M	15	25	180	0.60	50
SCI1608-R18 □	0.180	K / M	15	25	165	0.60	50
SCI1608-R22 □	0.220	K / M	15	25	150	0.80	50
SCI1608-R27 □	0.270	K / M	15	25	136	0.80	50
SCI1608-R33 □	0.330	K / M	15	25	125	0.85	35
SCI1608-R39 □	0.390	K / M	15	25	110	1.00	35
SCI1608-R47 □	0.470	K / M	15	25	105	1.35	35
SCI1608-R56 □	0.560	K / M	15	25	95	1.55	35
SCI1608-R68 □	0.680	K / M	15	25	90	1.70	35
SCI1608-R82 □	0.820	K / M	15	25	85	2.10	35
SCI1608-1R0 □	1.000	K / M	35	10	75	0.60	25
SCI1608-1R2 □	1.200	K / M	35	10	65	0.80	25
SCI1608-1R5 □	1.500	K / M	35	10	60	0.80	25
SCI1608-1R8 □	1.800	K / M	35	10	55	0.95	25
SCI1608-2R2 □	2.200	K / M	35	10	50	1.15	15
SCI1608-2R7 □	2.700	K / M	35	10	45	1.35	15
SCI1608-3R3 □	3.300	K / M	35	10	40	1.55	15
SCI1608-3R9 □	3.900	K / M	35	10	35	1.70	15
SCI1608-4R7 □	4.700	K / M	35	10	33	2.10	15
SCI1608-5R6 □	5.600	K / M	35	4	22	1.55	5
SCI1608-6R8 □	6.800	K / M	35	4	20	1.70	5
SCI1608-8R2 □	8.200	K / M	35	4	18	2.10	5
SCI1608-100 □	10.00	K / M	30	2	17	1.85	3
SCI1608-120 □	12.00	K / M	30	2	15	2.10	3
SCI1608-150 □	15.00	K / M	20	1	14	1.70	1



Characteristics-SCI2012

Part No.	Inductance (μH)	Tolerance	Thickness (mm)	Q (min)	Test Frequency (MHz)	SRF Min. (MHz)	RDC Max. (Ω)	IDC Max. (mA)
SCI2012-47NM	0.047	M	0.90 ± 0.2	15	50	320	0.20	300
SCI2012-68NM	0.068	M	0.90 ± 0.2	15	50	280	0.20	300
SCI2012-R10 □	0.100	K / M	0.90 ± 0.2	20	25	235	0.30	250
SCI2012-R12 □	0.120	K / M	0.90 ± 0.2	20	25	220	0.30	250
SCI2012-R15 □	0.150	K / M	0.90 ± 0.2	20	25	200	0.40	250
SCI2012-R18 □	0.180	K / M	0.90 ± 0.2	20	25	185	0.40	250
SCI2012-R22 □	0.220	K / M	0.90 ± 0.2	20	25	170	0.50	250
SCI2012-R27 □	0.270	K / M	0.90 ± 0.2	20	25	150	0.50	250
SCI2012-R33 □	0.330	K / M	0.90 ± 0.2	20	25	145	0.55	250
SCI2012-R39 □	0.390	K / M	0.90 ± 0.2	25	25	135	0.65	200
SCI2012-R47 □	0.470	K / M	0.90 ± 0.2	25	25	125	0.65	200
SCI2012-R56 □	0.560	K / M	0.90 ± 0.2	25	25	115	0.75	150
SCI2012-R68 □	0.680	K / M	0.90 ± 0.2	25	25	105	0.80	150
SCI2012-R82 □	0.820	K / M	0.90 ± 0.2	25	25	100	1.00	150
SCI2012-1R0 □	1.000	K / M	0.90 ± 0.2	45	10	75	0.40	50
SCI2012-1R2 □	1.200	K / M	0.90 ± 0.2	45	10	65	0.50	50
SCI2012-1R5 □	1.500	K / M	0.90 ± 0.2	45	10	60	0.50	50
SCI2012-1R8 □	1.800	K / M	0.90 ± 0.2	45	10	55	0.60	50
SCI2012-2R2 □	2.200	K / M	0.90 ± 0.2	45	10	50	0.65	30
SCI2012-2R7 □	2.700	K / M	1.20 ± 0.2	45	10	45	0.75	30
SCI2012-3R3 □	3.300	K / M	1.20 ± 0.2	45	10	41	0.80	30
SCI2012-3R9 □	3.900	K / M	1.20 ± 0.2	45	10	38	0.90	30
SCI2012-4R7 □	4.700	K / M	1.20 ± 0.2	45	10	35	1.00	30
SCI2012-5R6 □	5.600	K / M	1.20 ± 0.2	50	4.0	32	0.90	15
SCI2012-6R8 □	6.800	K / M	1.20 ± 0.2	50	4.0	29	1.00	15
SCI2012-8R2 □	8.200	K / M	1.20 ± 0.2	50	2.0	26	1.10	15
SCI2012-100 □	10.00	K / M	1.20 ± 0.2	50	2.0	24	1.15	15
SCI2012-120 □	12.00	K / M	1.20 ± 0.2	50	2.0	22	1.25	15
SCI2012-150 □	15.00	K / M	1.20 ± 0.2	30	1.0	19	0.80	5
SCI2012-180 □	18.00	K / M	1.25 ± 0.2	30	1.0	18	0.90	5
SCI2012-220 □	22.00	K / M	1.25 ± 0.2	30	1.0	16	1.10	5
SCI2012-270 □	27.00	K / M	1.25 ± 0.2	30	1.0	14	1.15	5
SCI2012-330 □	33.00	K / M	1.25 ± 0.2	30	0.4	13	1.25	5
SCI2012-390 □	39.00	K / M	1.25 ± 0.2	35	1.0	8	2.90	4
SCI2012-470 □	47.00	K / M	1.25 ± 0.2	35	1.0	8	3.00	4

Please note SCI2012 Series thickness, there are three types of thickness in this series.

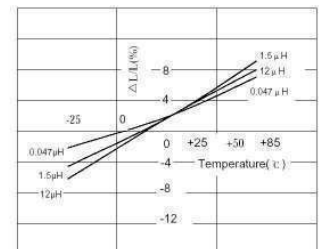
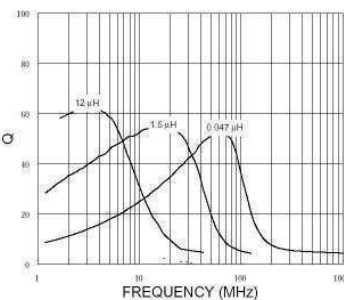
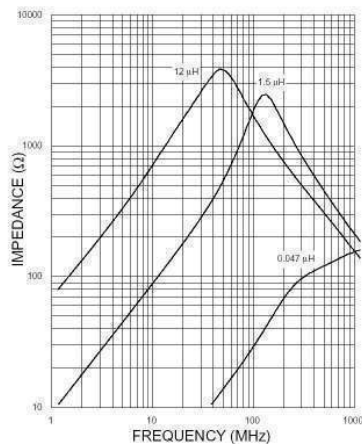
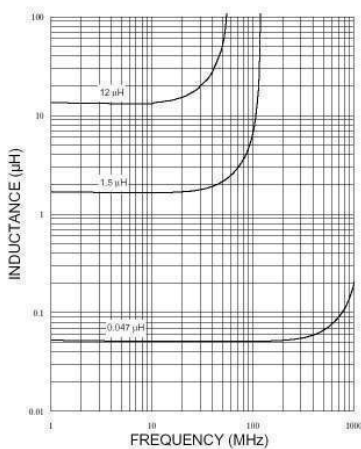



Characteristics-SCI3216

Part No.	Inductance (µH)	Tolerance	Q (min)	Test Frequency (MHz)	SRF Min. (MHz)	RDC Max. (Ω)	IDC Max. (mA)
SCI3216-47NM	0.047	M	20	50	320	0.15	300
SCI3216-68NM	0.068	M	20	50	280	0.25	300
SCI3216-R10 □	0.100	K / M	20	25	235	0.25	250
SCI3216-R12 □	0.120	K / M	20	25	220	0.30	250
SCI3216-R15 □	0.150	K / M	20	25	200	0.30	250
SCI3216-R18 □	0.180	K / M	20	25	185	0.40	250
SCI3216-R22 □	0.220	K / M	20	25	170	0.40	250
SCI3216-R27 □	0.270	K / M	20	25	150	0.50	250
SCI3216-R33 □	0.330	K / M	20	25	145	0.60	250
SCI3216-R39 □	0.390	K / M	25	25	135	0.50	200
SCI3216-R47 □	0.470	K / M	25	25	125	0.60	200
SCI3216-R56 □	0.560	K / M	25	25	115	0.70	150
SCI3216-R68 □	0.680	K / M	25	25	105	0.80	150
SCI3216-R82 □	0.820	K / M	25	25	100	0.90	150
SCI3216-1R0 □	1.000	K / M	45	10	75	0.40	100
SCI3216-1R2 □	1.200	K / M	45	10	65	0.50	100
SCI3216-1R5 □	1.500	K / M	45	10	60	0.50	50
SCI3216-1R8 □	1.800	K / M	45	10	55	0.50	50
SCI3216-2R2 □	2.200	K / M	45	10	50	0.60	50
SCI3216-2R7 □	2.700	K / M	45	10	45	0.60	50
SCI3216-3R3 □	3.300	K / M	45	10	41	0.70	50
SCI3216-3R9 □	3.900	K / M	45	10	38	0.80	50
SCI3216-4R7 □	4.700	K / M	45	10	35	0.90	50
SCI3216-5R6 □	5.600	K / M	50	4.0	32	0.70	25
SCI3216-6R8 □	6.800	K / M	50	4.0	29	0.80	25
SCI3216-8R2 □	8.200	K / M	50	4.0	26	0.90	25
SCI3216-100 □	10.00	K / M	50	2.0	24	1.00	25
SCI3216-120 □	12.00	K / M	50	2.0	22	1.05	15
SCI3216-150 □	15.00	K / M	35	1.0	19	0.70	5
SCI3216-180 □	18.00	K / M	35	1.0	18	0.70	5
SCI3216-220 □	22.00	K / M	35	1.0	16	0.90	5
SCI3216-270 □	27.00	K / M	35	1.0	14	0.90	5
SCI3216-330 □	33.00	K / M	35	1.0	13	1.05	5

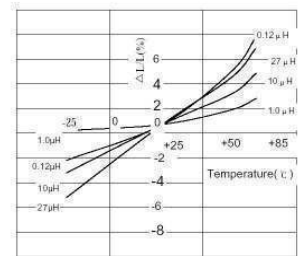
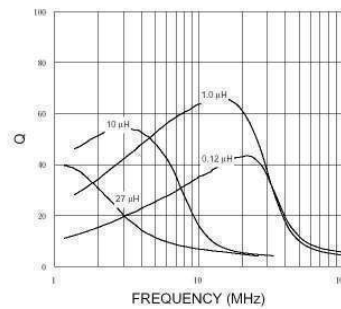
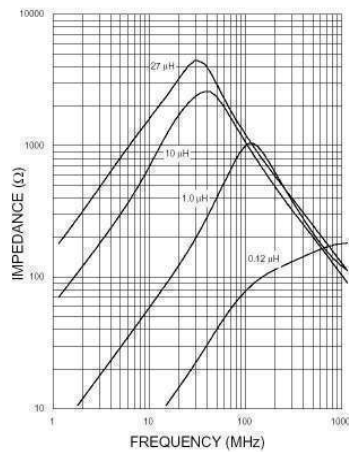
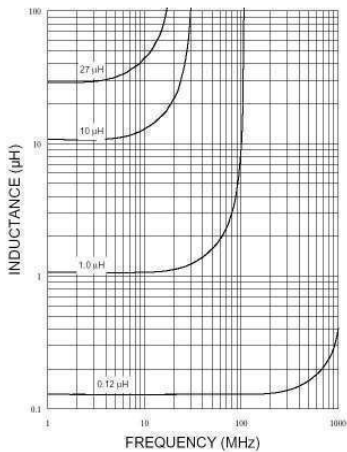

SMD RF Multilayer Chip Inductor – SCI-C Series

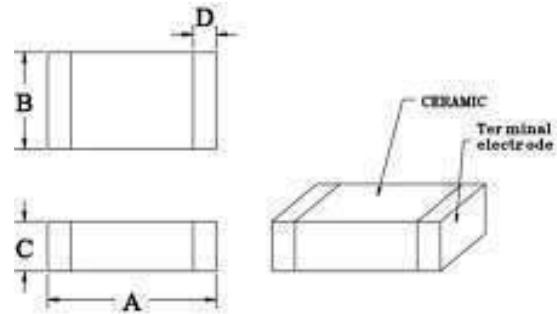

Features

- Miscellaneous high-frequency circuits
- EMI countermeasure in high-frequency circuits
- High SRF up to 6GHz and above

Ordering Information

SCI 1005C-4N7 K

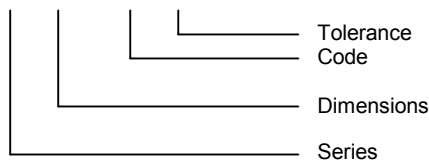

Dimensions

Part No.	A	B	C	D
SCI1005C (0402)	1.0 ± 0.1	0.5 ± 0.1	0.5 ± 0.1	0.1 Min
SCI1608C (0603)	1.6 ± 0.2	0.8 ± 0.2	0.8 ± 0.2	0.3 ± 0.2
SCI2012C (0805)	2.0 ± 0.2	1.2 ± 0.2	0.9 ± 0.2	0.5 ± 0.2

SIZE	SCI1005C	SCI1608C	SCI2012C
QTY/REEL	10000pcs.	4000pcs.	4000pcs.

Characteristics-SCI1005C

All Series: Tolerance: S = ± 0.3nH; J = ± 5%, K = ± 10%

Part No.	Inductance (nH) @100MHz	Tolerance	Q Typical		SRF Min. (MHz)	RDC Max. (Ω)	IDC Max. (mA)
			100 MHz	800 MHz			
SCI1005C-1N0S	1.0	S	10	28	13500	0.10	300
SCI1005C-1N2S	1.2	S	9	28	12000	0.10	300
SCI1005C-1N5S	1.5	S	10	30	10500	0.10	300
SCI1005C-1N8S	1.8	S	10	28	9400	0.10	300
SCI1005C-2N2S	2.2	S	10	30	8700	0.20	300
SCI1005C-2N7S	2.7	S	10	30	7700	0.20	300
SCI1005C-3N3 □	3.3	S / K	10	30	6800	0.30	300
SCI1005C-3N9 □	3.9	S / K	11	31	6300	0.30	300
SCI1005C-4N7 □	4.7	S / K	10	30	5700	0.40	300
SCI1005C-5N6 □	5.6	S / K	11	31	5100	0.40	300
SCI1005C-6N8 □	6.8	J / K	10	31	4550	0.50	300
SCI1005C-8N2 □	8.2	J / K	12	34	4100	0.50	300
SCI1005C-10N □	10.0	J / K	12	32	3750	0.60	300
SCI1005C-12N □	12.0	J / K	12	31	2950	0.60	300
SCI1005C-15N □	15.0	J / K	11	30	2600	0.70	300
SCI1005C-18N □	18.0	J / K	11	29	2350	0.80	300
SCI1005C-22N □	22.0	J / K	11	28	1950	0.90	300
SCI1005C-27N □	27.0	J / K	12	27	1750	1.00	300
SCI1005C-33N □	33.0	J / K	10	25	1700	1.50	200
SCI1005C-39N □	39.0	J / K	10	25	1650	1.80	200
SCI1005C-47N □	47.0	J / K	9	23	1300	2.00	200



Characteristics-SCI1608C

Part No.	Inductance (nH) @100MHz	Tolerance	Q Typical		SRF Min. (MHz)	RDC Max. (Ω)	IDC Max. (mA)
			100 MHz	800 MHz			
SCI1608C-1N2S	1.2	S	13	60	>6000	0.10	300
SCI1608C-1N5S	1.5	S	13	47	>6000	0.10	300
SCI1608C-1N8S	1.8	S	12	51	>6000	0.12	300
SCI1608C-2N2S	2.2	S	12	38	>6000	0.16	300
SCI1608C-2N7S	2.7	S	12	38	>6000	0.20	300
SCI1608C-3N3 □	3.3	S / K	12	41	5700	0.22	300
SCI1608C-3N9 □	3.9	S / K	13	50	5600	0.25	300
SCI1608C-4N7 □	4.7	S / K	12	41	4800	0.28	300
SCI1608C-5N6 □	5.6	S / K	12	42	4350	0.29	300
SCI1608C-6N8 □	6.8	J / K	12	40	3750	0.30	300
SCI1608C-8N2 □	8.2	J / K	13	34	3300	0.33	300
SCI1608C-10N □	10.0	J / K	13	45	2850	0.35	300
SCI1608C-12N □	12.0	J / K	15	46	2700	0.40	300
SCI1608C-15N □	15.0	J / K	15	48	2400	0.45	300
SCI1608C-18N □	18.0	J / K	16	48	2050	0.50	300
SCI1608C-22N □	22.0	J / K	17	45	1850	0.55	300
SCI1608C-27N □	27.0	J / K	17	43	1750	0.60	300
SCI1608C-33N □	33.0	J / K	18	39	1500	0.65	300
SCI1608C-39N □	39.0	J / K	17	37	1350	0.70	300
SCI1608C-47N □	47.0	J / K	17	35	1200	0.90	300
SCI1608C-56N □	56.0	J / K	17	32	1100	1.00	300
SCI1608C-68N □	68.0	J / K	18	34	1000	1.50	300
SCI1608C-82N □	82.0	J / K	18	32	900	1.80	300
SCI1608C-R10 □	100.0	J / K	15	16	830	2.10	300

Characteristics-SCI2012C

Part No.	Inductance (nH) @100MHz	Tolerance	Q Typical		SRF Min. (MHz)	RDC Max. (Ω)	IDC Max. (mA)
			100 MHz	800 MHz			
SCI2012C-1N5S	1.5	S	13	40	>6000	0.10	300
SCI2012C-1N8S	1.8	S	13	45	>6000	0.10	300
SCI2012C-2N2S	2.2	S	13	48	>6000	0.10	300
SCI2012C-2N7S	2.7	S	12	36	>6000	0.10	300
SCI2012C-3N3 □	3.3	S / K	13	56	>6000	0.13	300
SCI2012C-3N9 □	3.9	S / K	15	54	5400	0.15	300
SCI2012C-4N7 □	4.7	S / K	15	50	4500	0.20	300
SCI2012C-5N6 □	5.6	S / K	15	53	4000	0.23	300
SCI2012C-6N8 □	6.8	J / K	15	51	3650	0.25	300
SCI2012C-8N2 □	8.2	J / K	15	53	3000	0.28	300
SCI2012C-10N □	10.0	J / K	16	45	2500	0.30	300
SCI2012C-12N □	12.0	J / K	16	48	2450	0.35	300
SCI2012C-15N □	15.0	J / K	17	48	2000	0.40	300
SCI2012C-18N □	18.0	J / K	17	43	1750	0.45	300
SCI2012C-22N □	22.0	J / K	17	47	1700	0.50	300
SCI2012C-27N □	27.0	J / K	18	38	1550	0.55	300
SCI2012C-33N □	33.0	J / K	18	35	1350	0.60	300
SCI2012C-39N □	39.0	J / K	18	40	1300	0.65	300
SCI2012C-47N □	47.0	J / K	18	33	1200	0.70	300
SCI2012C-56N □	56.0	J / K	19	31	1150	0.75	300
SCI2012C-68N □	68.0	J / K	19	28	1000	0.85	300
SCI2012C-82N □	82.0	J / K	20	9	850	0.90	300
SCI2012C-R10 □	100.0	J / K	18	-	730	1.00	300
SCI2012C-R12 □	120.0	J / K	19	-	650	1.30	250
SCI2012C-R15 □	150.0	J / K	20	-	550	1.50	250
SCI2012C-R18 □	180.0	J / K	20	-	500	1.80	250
SCI2012C-R22 □	220.0	J / K	20	-	450	2.00	200
SCI2012C-R27 □	270.0	J / K	20	-	400	2.50	200
SCI2012C-R33 □	330.0	J / K	20	-	380	3.00	150
SCI2012C-R39 □	390.0	J / K	20	-	330	3.50	150
SCI2012C-R47 □	470.0	J / K	19	-	300	4.00	100

Wire Wound Inductor – SWI Series

SCHMID-M

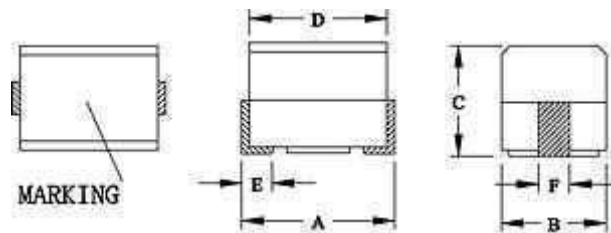
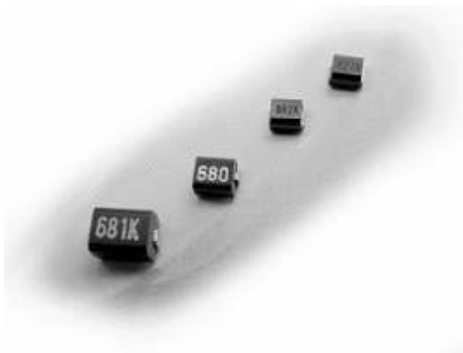

Features

- Resistant to mechanical shocks and pressures
- Accurate dimensions for automatically surface mounting
- This series has low resistance and high current, suitable for power line applications

Dimensions

Part No.	A	B	C	D	E	F
SWI252018 (1008)	2.5 ± 0.2	2.0 ± 0.2	1.8 ± 0.2	2.2 ± 0.2	0.50	1.2
SWI322522 (1210)	3.2 ± 0.3	2.5 ± 0.2	2.2 ± 0.2	2.9 ± 0.2	0.75	1.0
SWI453232 (1812)	4.5 ± 0.3	3.2 ± 0.2	3.2 ± 0.2	4.2 ± 0.2	1.00	1.2

Ordering Information

SWI 252018 – 4R7 K

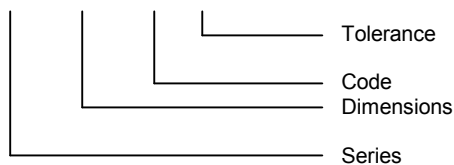

SIZE	SWI252018	SWI352522	SWI453232
QTY/REEL	2000pcs.	2000pcs.	500pcs.

Characteristics-SWI252018

Tolerance: J = ± 5%; K = ± 10%; M = ± 20%, K tolerance is standard.

Part No.	Inductance (µH)	Q (min)	Test Frequency (MHz)	SRF Min. (MHz)	RDC Max. (Ω)	IDC Max. (mA)
SWI252018-R22 □	0.22	25	25.2	230	0.50	430
SWI252018-R27 □	0.27	25	25.2	210	0.55	420
SWI252018-R33 □	0.33	25	25.2	190	0.60	400
SWI252018-R39 □	0.39	25	25.2	175	0.65	375
SWI252018-R47 □	0.47	25	25.2	160	0.68	350
SWI252018-R56 □	0.56	25	25.2	150	0.75	325
SWI252018-R68 □	0.68	25	25.2	135	0.85	300
SWI252018-R82 □	0.82	25	25.2	125	1.00	260
SWI252018-1R0 □	1.00	25	7.96	115	1.11	245
SWI252018-1R2 □	1.20	25	7.96	100	1.20	230
SWI252018-1R5 □	1.50	25	7.96	90	1.30	220
SWI252018-1R8 □	1.80	25	7.96	85	1.45	210
SWI252018-2R2 □	2.20	25	7.96	80	1.55	200
SWI252018-2R7 □	2.70	25	7.96	75	1.70	195
SWI252018-3R3 □	3.30	25	7.96	65	1.90	185
SWI252018-3R9 □	3.90	25	7.96	60	2.10	180
SWI252018-4R7 □	4.70	25	7.96	55	2.30	175
SWI252018-5R6 □	5.60	25	7.96	50	2.50	170
SWI252018-6R8 □	6.80	25	7.96	45	2.70	165
SWI252018-8R2 □	8.20	25	7.96	40	3.05	160
SWI252018-100 □	10	25	2.52	32	3.50	155
SWI252018-120 □	12	25	2.52	30	3.80	150
SWI252018-150 □	15	25	2.52	28	4.40	140
SWI252018-180 □	18	25	2.52	25	4.80	130
SWI252018-220 □	22	25	2.52	22	5.50	125
SWI252018-270 □	27	20	2.52	21	6.30	115
SWI252018-330 □	33	20	2.52	20	7.10	110

SWI252018-390 □	39	20	2.52	18	9.50	90
SWI252018-470 □	47	20	2.52	17	11.1	80
SWI252018-560 □	56	20	2.52	16	12.1	75
SWI252018-680 □	68	20	2.52	15	16.6	70
SWI252018-820 □	82	20	2.52	13	19.0	66
SWI252018-101 □	100	15	0.796	12	21.0	60

Characteristics-SWI322522

Part No.	Inductance (μ H)	Q (min)	Test Frequency (MHz)	SRF Min. (MHz)	RDC Max. (Ω)	IDC Max. (mA)
SWI322522-R12 □	0.12	30	25.2	500	0.22	450
SWI322522-R15 □	0.15	30	25.2	450	0.25	450
SWI322522-R18 □	0.18	30	25.2	400	0.28	450
SWI322522-R22 □	0.22	30	25.2	350	0.32	450
SWI322522-R27 □	0.27	30	25.2	320	0.36	450
SWI322522-R33 □	0.33	30	25.2	300	0.40	450
SWI322522-R39 □	0.39	30	25.2	250	0.45	450
SWI322522-R47 □	0.47	30	25.2	220	0.50	450
SWI322522-R56 □	0.56	30	25.2	180	0.55	450
SWI322522-R68 □	0.68	30	25.2	160	0.60	450
SWI322522-R82 □	0.82	30	25.2	140	0.65	450
SWI322522-1R0 □	1.00	30	7.96	120	0.70	400
SWI322522-1R2 □	1.20	30	7.96	100	0.75	390
SWI322522-1R5 □	1.50	30	7.96	85	0.85	370
SWI322522-1R8 □	1.80	30	7.96	80	0.90	350
SWI322522-2R2 □	2.20	30	7.96	75	1.00	320
SWI322522-2R7 □	2.70	30	7.96	70	1.10	290
SWI322522-3R3 □	3.30	30	7.96	60	1.20	260
SWI322522-3R9 □	3.90	30	7.96	55	1.30	250
SWI322522-4R7 □	4.70	30	7.96	50	1.50	220
SWI322522-5R6 □	5.60	30	7.96	47	1.60	200
SWI322522-6R8 □	6.80	30	7.96	43	1.80	180
SWI322522-8R2 □	8.20	30	7.96	40	2.00	170
SWI322522-100 □	10	30	2.52	36	2.10	150
SWI322522-120 □	12	30	2.52	33	2.50	140
SWI322522-150 □	15	30	2.52	28	2.80	130
SWI322522-180 □	18	30	2.52	25	3.30	120
SWI322522-220 □	22	30	2.52	23	3.70	110
SWI322522-270 □	27	30	2.52	18	5.00	80
SWI322522-330 □	33	30	2.52	17	5.60	70
SWI322522-390 □	39	30	2.52	16	6.40	65
SWI322522-470 □	47	30	2.52	15	7.00	60
SWI322522-560 □	56	30	2.52	13	8.00	55
SWI322522-680 □	68	30	2.52	12	9.00	50
SWI322522-820 □	82	30	0.796	11	10.0	45
SWI322522-101 □	100	20	0.796	10	11.0	40
SWI322522-121 □	120	20	0.796	10	12.0	70
SWI322522-151 □	150	20	0.796	8	15.0	65
SWI322522-181 □	180	20	0.796	7	17.0	60
SWI322522-221 □	220	20	0.796	7	21.0	60

Characteristics-SWI453232

Part No.	Inductance (μ H)	Q (min)	Test Frequency (MHz)	SRF Min. (MHz)	RDC Max. (Ω)	IDC Max. (mA)
SWI453232-R10 □	0.10	35	25.2	300	0.20	800
SWI453232-R12 □	0.12	35	25.2	280	0.20	770
SWI453232-R15 □	0.15	35	25.2	250	0.20	730
SWI453232-R18 □	0.18	35	25.2	200	0.20	700
SWI453232-R22 □	0.22	40	25.2	220	0.30	665
SWI453232-R27 □	0.27	40	25.2	180	0.30	635
SWI453232-R33 □	0.33	40	25.2	165	0.30	605
SWI453232-R39 □	0.39	40	25.2	150	0.30	575
SWI453232-R47 □	0.47	40	25.2	145	0.30	545
SWI453232-R56 □	0.56	40	25.2	140	0.40	520
SWI453232-R68 □	0.68	40	25.2	135	0.40	500
SWI453232-R82 □	0.82	40	25.2	130	0.50	475
SWI453232-1R0 □	1.00	50	7.96	100	0.50	450
SWI453232-1R2 □	1.20	50	7.96	80	0.60	430
SWI453232-1R5 □	1.50	50	7.96	70	0.60	410
SWI453232-1R8 □	1.80	50	7.96	60	0.70	390
SWI453232-2R2 □	2.20	50	7.96	65	0.70	380
SWI453232-2R7 □	2.70	50	7.96	50	0.80	370
SWI453232-3R3 □	3.30	50	7.96	45	0.80	355
SWI453232-3R9 □	3.90	50	7.96	40	0.90	330
SWI453232-4R7 □	4.70	50	7.96	35	1.00	315
SWI453232-5R6 □	5.60	50	7.96	33	1.10	300
SWI453232-6R8 □	6.80	50	7.96	27	1.20	285
SWI453232-8R2 □	8.20	50	7.96	25	1.40	275
SWI453232-100 □	10	50	2.52	20	1.60	250
SWI453232-120 □	12	50	2.52	18	2.00	225
SWI453232-150 □	15	50	2.52	17	2.50	200
SWI453232-180 □	18	50	2.52	15	2.80	190
SWI453232-220 □	22	50	2.52	13	3.20	180
SWI453232-270 □	27	50	2.52	12	3.60	170
SWI453232-330 □	33	50	2.52	11	4.00	160
SWI453232-390 □	39	50	2.52	10	4.50	150
SWI453232-470 □	47	50	2.52	10	5.00	140
SWI453232-560 □	56	50	2.52	9.0	5.50	135
SWI453232-680 □	68	50	2.52	9.0	6.00	130
SWI453232-820 □	82	50	2.52	8.0	7.00	120
SWI453232-101 □	100	40	0.796	8.0	8.00	110
SWI453232-121 □	120	40	0.796	6.0	8.00	110
SWI453232-151 □	150	40	0.796	5.0	9.00	105
SWI453232-181 □	180	40	0.796	5.0	9.50	102
SWI453232-221 □	220	40	0.796	4.0	10.0	100
SWI453232-271 □	270	40	0.796	4.0	12.0	92
SWI453232-331 □	330	40	0.796	3.5	14.0	85
SWI453232-391 □	390	40	0.796	3.0	18.0	80
SWI453232-471 □	470	40	0.796	3.0	26.0	62
SWI453232-561 □	560	30	0.796	3.0	30.0	50
SWI453232-681 □	680	30	0.796	3.0	30.0	50
SWI453232-821 □	820	30	0.796	2.5	35.0	30
SWI453232-102 □	1000	20	0.252	2.5	40.0	30

Wire wound ferrite chip inductor- SFL series

SCHMID-M

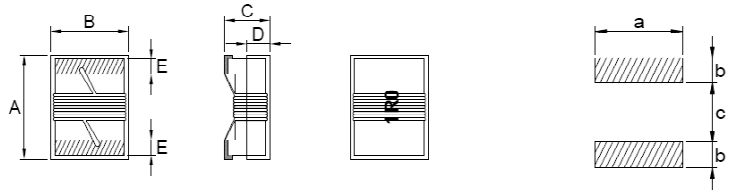
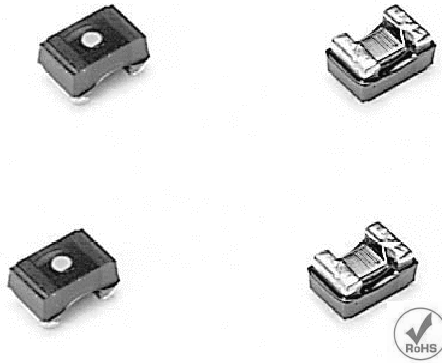

Series	A	B	C	D	E	a	b	c
SFL201212	2,40 max	1,60 max	1,40 max	0,51 typ.	0,40 ± 0,1	1,8	0,90	1,00
SFL252018	2,90 max	2,50 max	2,10 max	1,20 typ.	0,55 ± 0,1	2,54	1,00	1,30
SFL322522	3,60 max	2,80 max	2,50 max	0,80 typ.	0,55 ± 0,1	2,80	1,00	2,00

Features

- Ferrite core wire wound construction.
- Provide high Q characteristics.
- Precision inductance tolerance is available.
- Small footprint as well as profile.
- All support Lead-Free Parts.
- Standard packaging is 2000 pcs/reel

Application

- Personal computers, Hard disk drives.
- ADSL modem and Cable modem.
- Digital camera or portable product.
- Measuring instruments.

Standard parts

SFL201212-xxx_	Inductance (uH)		Q value / MHz Min.	SRF (MHz) Min.	DCR (Ω) Max.	Saturation Current (mA) Max.
	uH/MHz	Tolerance				
SFL201212-R18_	0,18/25,2	J,K	30/100	850	0,34	460
SFL201212-R27_	0,27/25,2	J,K	30/100	660	0,43	440
SFL201212-R47_	0,47/25,2	J,K	30/100	570	0,54	420
SFL201212-R56_	0,56/25,2	J,K	30/100	560	0,64	400
SFL201212-R68_	0,68/25,2	J,K	30/100	480	0,68	350
SFL201212-R82_	0,82/25,2	J,K	30/100	449	0,77	325
SFL201212-1R0_	1,0/25,2	J,K	30/100	394	0,86	300
SFL201212-1R2_	1,2/25,2	J,K	25/100	297	0,97	260
SFL201212-1R5_	1,5/25,2	J,K	25/25,2	206	1,08	250
SFL201212-1R8_	1,8/25,2	J,K	25/25,2	177	1,18	230
SFL201212-2R2_	2,2/25,2	J,K	20/25,2	141	1,32	220
SFL201212-2R7_	2,7/25,2	J,K	20/25,2	128	1,42	210
SFL201212-3R3_	3,3/25,2	J,K	15/25,2	110	1,73	200
SFL201212-3R9_	3,9/25,2	J,K	15/25,2	103	1,72	195
SFL201212-4R7_	4,7/25,2	J,K	15/25,2	98	1,87	185
SFL201212-5R6_	5,6/7,96	J,K	15/7,96	96	2,18	180
SFL201212-6R8_	6,8/7,96	J,K	15/7,96	82	2,90	175
SFL201212-8R2_	8,2/7,96	J,K	15/7,96	64	3,31	140
SFL201212-100_	10/7,96	J,K	15/7,96	56	3,72	115

SFL252018-xxx_	Inductance (uH)		Q value / MHz Min.	SRF (MHz) Min.	DCR (Ω) Max.	Saturation Current (mA) Max.
	uH/MHz	Tolerance				
SFL252018-1R0_	1,0/25,2	J,K	30/25,2	285	0,80	400
SFL252018-1R2_	1,2/25,2	J,K	25/25,2	265	0,87	300
SFL252018-1R5_	1,5/25,2	J,K	25/25,2	235	0,98	206
SFL252018-1R8_	1,8/25,2	J,K	25/25,2	226	1,10	245
SFL252018-2R2_	2,2/25,2	J,K	25/25,2	198	1,22	230
SFL252018-2R7_	2,7/25,2	J,K	25/25,2	180	1,33	220
SFL252018-3R3_	3,3/25,2	J,K	25/25,2	143	1,46	210
SFL252018-3R9_	3,9/25,2	J,K	25/25,2	136	1,63	200
SFL252018-4R7_	4,7/25,2	J,K	25/25,2	105	1,76	195
SFL252018-5R6_	5,6/25,2	J,K	25/25,2	88	1,97	185
SFL252018-6R8_	6,8/7,96	J,K	25/7,96	56	1,79	190
SFL252018-8R2_	8,2/7,96	J,K	25/7,96	48	2,03	180
SFL252018-100_	10/7,96	J,K	25/7,96	44	2,92	165
SFL252018-120_	12/7,96	J,K	25/7,96	42	3,11	160
SFL252018-150_	15/7,96	J,K	25/7,96	37	3,58	155
SFL252018-180_	18/2,52	J,K	20/2,52	32	3,89	150
SFL252018-220_	22/2,52	J,K	20/2,52	28	4,38	140
SFL252018-270_	27/2,52	J,K	20/2,52	24	4,92	130
SFL252018-330_	33/2,52	J,K	20/2,52	22	5,50	125
SFL252018-390_	39/2,52	J,K	20/2,52	20	7,51	110
SFL252018-470_	47/2,52	J,K	20/2,52	18	8,34	100
SFL252018-560_	56/2,52	J,K	20/2,52	16	9,18	95
SFL252018-680_	68/2,52	J,K	20/2,52	14	9,61	90
SFL252018-820_	82/2,52	J,K	20/2,52	12	11,54	80
SFL252018-101_	100/1,0	K	8/1,0	7	19,6	200

SFL322522-xxx	Inductance (uH)		Q value / MHz Min.	SRF (MHz) Min.	DCR (Ω) Max.	Saturation Current (mA) Max.
	uH/MHz	Tolerance				
SFL322522-R82_	0,82/25,2	J,K	30/25,2	310	0,54	630
SFL322522-1R0_	1,0/25,2	J,K	30/25,2	239	0,54	630
SFL322522-1R2_	1,2/25,2	J,K	30/25,2	221	0,54	630
SFL322522-1R5_	1,5/25,2	J,K	30/25,2	209	0,54	630
SFL322522-1R8_	1,8/25,2	J,K	30/25,2	203	0,62	630
SFL322522-2R2_	2,2/25,2	J,K	30/25,2	187	0,71	630
SFL322522-2R7_	2,7/25,2	J,K	30/25,2	157	0,74	630
SFL322522-3R3_	3,3/25,2	J,K	30/25,2	146	0,83	600
SFL322522-3R9_	3,9/25,2	J,K	30/25,2	139	1,74	380
SFL322522-4R7_	4,7/25,2	J,K	30/25,2	124	1,90	360
SFL322522-5R6_	5,6/25,2	J,K	30/25,2	114	2,05	330
SFL322522-6R8_	6,8/7,96	J,K	30/7,96	109	1,37	450
SFL322522-8R2_	8,2/7,96	J,K	30/7,96	104	1,50	420
SFL322522-100_	10/7,96	J,K	25/7,96	87	1,70	400
SFL322522-120_	12/7,96	J,K	25/7,96	76	1,88	360
SFL322522-150_	15/7,96	J,K	25/7,96	67	2,22	340
SFL322522-180_	18/7,96	J,K	25/7,96	57	2,42	330
SFL322522-220_	22/7,96	J,K	25/7,96	48	2,66	300
SFL322522-270_	27/2,52	J,K	25/2,52	38	2,99	250
SFL322522-330_	33/2,52	J,K	25/2,52	26	3,24	220
SFL322522-390_	39/2,52	J,K	25/2,52	24	3,61	195
SFL322522-470_	47/2,52	J,K	25/2,52	22	3,96	195
SFL322522-560_	56/2,52	J,K	25/2,52	20	4,36	190
SFL322522-680_	68/2,52	J,K	25/2,52	18	4,73	180
SFL322522-820_	82/2,52	J,K	25/2,52	16	5,95	160
SFL322522-101_	100/2,52	J,K	25/2,52	14	6,62	150
SFL322522-121_	120/2,52	J,K	15/2,52	12	7,33	140
SFL322522-151_	150/2,52	J,K	15/2,52	11	8,29	135
SFL322522-181_	180/2,52	J,K	15/2,52	10	11,53	100
SFL322522-221_	220/1,0	J,K	15/2,52	8	12,48	80

Wire Wound Inductor with Magnetic shielding – SWI1008P

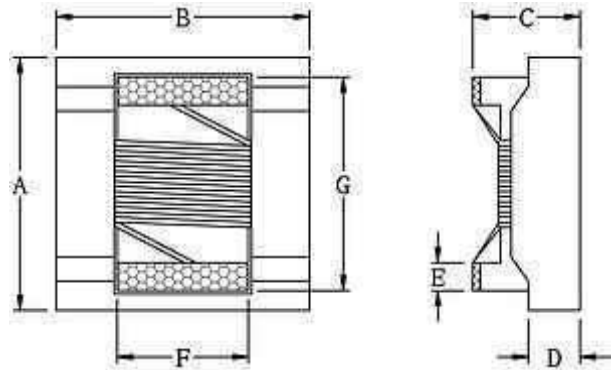
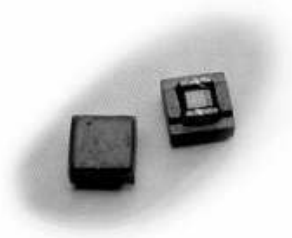

Features

- Excellent Solderability and resistance to soldering heat
- Wound chip inductor with magnetic shielding, which is suitable for high current applications such as notebook, electronic devices etc.
- High reliability and easy surface mount assembly

Dimensions

Part No.	A	B	C	D	E	F	G
SWI1008P	3.6 ± 0.2	3.6 ± 0.2	2.5 ± 0.2	1.6 ± 0.2	0.50 ± 0.1	2.0 ± 0.2	2.5 ± 0.1

Ordering Information

SWI 1008P – 4R7 M

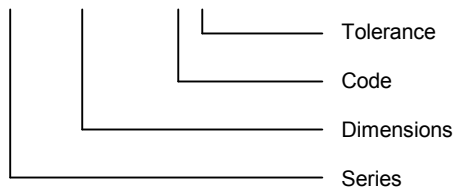

SIZE	SWI1008P
QTY/REEL	750pcs.

Characteristics

Tolerance: M = ± 20%, M tolerance is standard.

Part No.	Inductance (µH)	Q (min)	Test Frequency (KHz)	SRF Min. (MHz)	RDC Max. (Ω)	IDC Max. (mA)
SWI1008P-1R0M	1.0	35	100	344	0.05	1000
SWI1008P-1R5M	1.5	35	100	260	0.06	800
SWI1008P-1R8M	1.8	35	100	225	0.09	600
SWI1008P-2R7M	2.7	38	100	185	0.14	650
SWI1008P-3R9M	3.9	38	100	175	0.26	650
SWI1008P-4R7M	4.7	38	100	160	0.35	500
SWI1008P-5R6M	5.6	38	100	150	0.40	450
SWI1008P-6R8M	6.8	38	100	120	0.60	400
SWI1008P-100M	10	38	100	100	0.95	250
SWI1008P-150M	15	38	100	35	1.15	220
SWI1008P-220M	22	40	100	26	1.40	180
SWI1008P-330M	33	45	100	20	1.60	150
SWI1008P-390M	39	45	100	14	1.85	130
SWI1008P-470M	47	45	100	14	2.50	110
SWI1008P-680M	68	45	100	12	3.80	100
SWI1008P-820M	82	45	100	9.0	4.20	100
SWI1008P-101M	100	45	100	7.0	5.80	80
SWI1008P-121M	120	45	100	6.0	6.20	60
SWI1008P-151M	150	40	100	5.6	7.50	50
SWI1008P-221M	220	40	100	4.0	10.0	50
SWI1008P-331M	330	40	100	3.8	11.5	50
SWI1008P-471M	470	35	100	2.0	16.5	50
SWI1008P-561M	560	35	100	2.0	18.0	30
SWI1008P-681M	680	30	100	1.8	24.0	30
SWI1008P-821M	820	30	100	1.5	26.0	30
SWI1008P-102M	1000	30	100	1.3	30.0	30

RF Wire Wound Inductor- SWI-C Series

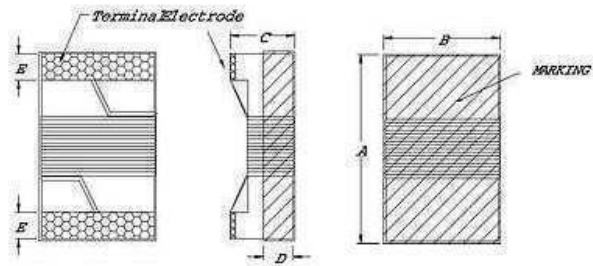

Features

- High reliability and easy surface mount assembly
- Consisting of sizes 0402-1210
- High quality factor

Dimensions

Part No.	A	B	C	D	E
SWI0402C	1.0 ± 0.10	0.55 ± 0.10	0.50 ± 0.10	0.5 REF.	0.20 ± 0.10
SWI0603C	1.6 ± 0.20	1.05 ± 0.20	1.05 ± 0.20	0.5 REF.	0.35 ± 0.10
SWI0805C/F	2.0 ± 0.20	1.25 ± 0.20	1.20 ± 0.20	0.5 REF.	0.40 ± 0.20
SWI1008C/F	2.5 ± 0.20	2.00 ± 0.20	1.60 ± 0.20	0.5 REF.	0.50 ± 0.10
SWI1210C/F	3.2 ± 0.20	2.50 ± 0.20	2.20 ± 0.20	0.5 REF.	0.50 ± 0.10

Material Type : C = Ceramic Material ; F = Ferrite Material

Ordering Information

SWI 0402C-47N K

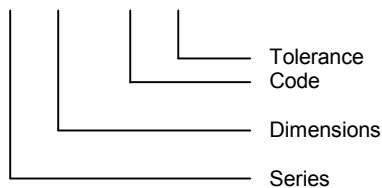

TYPE	SWI0402C	SWI0603C	SWI0805C/F	SWI1008C/F	SWI1210C/F
QTY /REEL	10000 pcs.	3000 pcs.	2000 pcs.	2000 pcs.	2000 pcs.

Characteristics-SWI0402C

All Series: Tolerance: S = ± 0.3nH; G = ± 2%; J = ± 5%; K = ± 10%

Part No.	Inductance (nH)	Q Typical		Test Frequency (MHz)	SRF Min. (MHz)	RDC Max. (Ω)	IDC Max. (mA)
		min	900 MHz				
SWI0402C-1N0S	1.0	13	26	250	6000	0.045	1360
SWI0402C-2N0S	2.0	16	30	250	6000	0.070	1040
SWI0402C-2N2S	2.2	18	32	250	6000	0.070	960
SWI0402C-3N3S	3.3	20	41	250	6000	0.066	840
SWI0402C-3N6S	3.6	20	43	250	6000	0.066	840
SWI0402C-3N9S	3.9	20	41	250	5800	0.066	840
SWI0402C-5N1 □	5.1	23	49	250	5800	0.083	800
SWI0402C-5N6 □	5.6	23	46	250	5800	0.083	760
SWI0402C-6N2 □	6.2	23	49	250	5800	0.083	760
SWI0402C-7N5 □	7.5	25	50	250	5800	0.104	680
SWI0402C-8N2 □	8.2	25	49	250	4400	0.104	680
SWI0402C-9N0 □	9.0	25	49	250	4160	0.104	680
SWI0402C-10N □	10.0	23	47	250	3900	0.195	480
SWI0402C-11N □	11.0	26	56	250	3680	0.120	640
SWI0402C-12N □	12.0	26	51	250	3600	0.120	640
SWI0402C-15N □	15.0	26	54	250	3280	0.172	560
SWI0402C-19N □	19.0	26	50	250	3040	0.202	480
SWI0402C-23N □	23.0	26	53	250	2720	0.214	400
SWI0402C-27N □	27.0	26	48	250	2480	0.298	400
SWI0402C-36N □	36.0	26	48	250	2320	0.403	320
SWI0402C-40N □	40.0	26	48	250	2240	0.438	320
SWI0402C-47N □	47.0	26	46	200	2100	0.830	150



Characteristics-SWI0603C

Part No.	Inductance (nH)	Q Typical		Test Frequency (MHz)	SRF Min. (MHz)	RDC Max. (Ω)	IDC Max. (mA)
		min	900 MHz				
SWI0603C-2N0S	2.0	16	31	250	6900	0.08	700
SWI0603C-3N9S	3.9	22	51	250	6900	0.08	700
SWI0603C-4N7S	4.7	20	47	250	5800	0.11	700
SWI0603C-6N8 □	6.8	30	63	250	5800	0.11	700
SWI0603C-8N2 □	8.2	30	72	250	4600	0.10	700
SWI0603C-10N □	10	30	66	250	4800	0.13	700
SWI0603C-12N □	12	35	72	250	4000	0.13	700
SWI0603C-15N □	15	35	68	250	4000	0.17	700
SWI0603C-18N □	18	38	77	250	3100	0.17	700
SWI0603C-22N □	22	38	70	250	3000	0.22	700
SWI0603C-27N □	27	40	75	250	2800	0.22	600
SWI0603C-33N □	33	43	78	250	2300	0.22	600
SWI0603C-39N □	39	43	66	250	2200	0.25	600
SWI0603C-47N □	47	40	65	250	2000	0.28	600
SWI0603C-56N □	56	40	66	200	1900	0.31	600
SWI0603C-68N □	68	40	57	200	1700	0.34	600
SWI0603C-72N □	72	35	60	200	1700	0.49	400
SWI0603C-82N □	82	35	58	150	1700	0.54	400
SWI0603C-R10 □	100	35	51	150	1400	0.63	400
SWI0603C-R12 □	120	35	45	150	1300	0.65	300
SWI0603C-R15 □	150	35	33	150	1000	0.92	280
SWI0603C-R18 □	180	30	26	100	1000	1.25	240
SWI0603C-R22 □	220	30	23	100	1000	1.70	200
SWI0603C-R27 □	270	30	10	100	1000	1.80	170

Characteristics-SWI0805C

Part No.	Inductance (nH)	Q (min)	Test Frequency L (MHz)	Test Frequency Q (MHz)	SRF Min. (MHz)	RDC Max. (Ω)	IDC Max. (mA)
SWI0805C-2N2S	2.2	50	250	1000	6000	0.06	800
SWI0805C-2N7S	2.7	35	250	1000	6000	0.08	800
SWI0805C-3N3S	3.3	60	250	1000	6000	0.08	800
SWI0805C-3N9S	3.9	60	250	1000	6000	0.06	600
SWI0805C-4N7S	4.7	60	250	1000	5800	0.06	600
SWI0805C-5N6 □	5.6	60	250	1000	5800	0.08	600
SWI0805C-6N8 □	6.8	60	250	1000	5500	0.06	600
SWI0805C-8N2 □	8.2	60	250	1000	5500	0.06	600
SWI0805C-10N □	10	60	250	500	4800	0.08	600
SWI0805C-12N □	12	60	250	500	4100	0.08	600
SWI0805C-15N □	15	60	250	500	3600	0.08	600
SWI0805C-18N □	18	60	250	500	3400	0.08	600
SWI0805C-22N □	22	60	250	500	3300	0.10	600
SWI0805C-27N □	27	60	250	500	2600	0.12	600
SWI0805C-33N □	33	60	250	500	2400	0.15	500
SWI0805C-39N □	39	60	250	500	2100	0.18	500
SWI0805C-47N □	47	60	200	500	1700	0.15	500
SWI0805C-56N □	56	60	200	500	1600	0.25	500
SWI0805C-68N □	68	60	200	500	1450	0.27	500
SWI0805C-82N □	82	60	150	500	1350	0.32	500
SWI0805C-R10 □	100	60	150	500	1200	0.43	500
SWI0805C-R12 □	120	50	150	250	1100	0.48	500
SWI0805C-R15 □	150	50	100	250	950	0.56	400
SWI0805C-R18 □	180	50	100	250	900	0.78	400
SWI0805C-R22 □	220	50	100	250	860	1.00	400
SWI0805C-R27 □	270	45	100	250	850	1.46	350
SWI0805C-R33 □	330	45	100	250	800	1.65	300
SWI0805C-R39 □	390	45	100	250	780	2.20	210



Characteristics-SWI1008C

Part No.	Inductance (nH)	Q (min)	Test Frequency L (MHz)	Test Frequency Q (MHz)	SRF Min. (MHz)	RDC Max. (Ω)	IDC Max. (mA)
SWI1008C-3N3 □	3.3	50	100	1000	6000	0.06	1000
SWI1008C-6N8 □	6.8	50	100	1000	5500	0.06	1000
SWI1008C-8N2 □	8.2	50	100	1000	5500	0.06	1000
SWI1008C-10N □	10	50	100	1000	4300	0.08	1000
SWI1008C-12N □	12	60	100	500	3600	0.08	1000
SWI1008C-15N □	15	60	100	500	2700	0.08	1000
SWI1008C-18N □	18	60	100	350	2700	0.10	1000
SWI1008C-22N □	22	60	100	350	2500	0.10	1000
SWI1008C-27N □	27	60	100	350	1800	0.10	1000
SWI1008C-33N □	33	60	100	350	1700	0.10	1000
SWI1008C-39N □	39	60	100	350	1500	0.10	1000
SWI1008C-47N □	47	60	100	350	1500	0.10	1000
SWI1008C-56N □	56	60	100	350	1350	0.12	1000
SWI1008C-68N □	68	60	100	350	1300	0.15	1000
SWI1008C-82N □	82	60	100	350	1100	0.18	1000
SWI1008C-R10 □	100	60	100	350	1100	0.18	1000
SWI1008C-R12 □	120	45	25	100	950	0.20	800
SWI1008C-R15 □	150	45	25	100	880	0.22	800
SWI1008C-R18 □	180	45	25	100	800	0.33	800
SWI1008C-R22 □	220	45	25	100	730	0.45	800
SWI1008C-R27 □	270	45	25	100	650	0.75	600
SWI1008C-R33 □	330	45	25	100	570	0.90	500
SWI1008C-R39 □	390	45	25	100	530	1.06	470
SWI1008C-R47 □	470	45	25	100	480	1.17	420
SWI1008C-R56 □	560	45	25	100	430	1.50	310
SWI1008C-R68 □	680	45	25	100	380	2.06	230
SWI1008C-R75 □	750	45	25	100	360	2.20	200
SWI1008C-R82 □	820	45	25	100	350	2.30	180
SWI1008C-R91 □	910	45	25	100	330	3.18	150
SWI1008C-1R0 □	1000	35	25	50	310	3.30	120

Characteristics-SWI1210C

Part No.	Inductance (nH)	Q (min)	Test Frequency L (MHz)	Test Frequency Q (MHz)	SRF Min. (MHz)	RDC Max. (Ω)	IDC Max. (mA)
SWI1210C-4N7 □	4.7	50	100	1000	6000	0.06	1000
SWI1210C-5N6 □	5.6	50	100	1000	5500	0.08	1000
SWI1210C-10N □	10	60	100	500	4000	0.06	1000
SWI1210C-12N □	12	60	100	500	3400	0.06	1000
SWI1210C-15N □	15	60	100	500	3200	0.06	1000
SWI1210C-18N □	18	60	100	300	2800	0.06	1000
SWI1210C-22N □	22	60	100	300	2300	0.08	1000
SWI1210C-27N □	27	60	100	300	2000	0.08	1000
SWI1210C-33N □	33	60	100	300	1800	0.08	1000
SWI1210C-39N □	39	60	100	300	1800	0.08	1000
SWI1210C-47N □	47	60	100	300	1600	0.08	1000
SWI1210C-56N □	56	60	100	300	1500	0.10	1000
SWI1210C-68N □	68	60	100	300	1300	0.10	1000
SWI1210C-82N □	82	60	100	300	1200	0.10	1000
SWI1210C-R10 □	100	60	100	300	1100	0.10	1000
SWI1210C-R12 □	120	60	50	300	900	0.12	800
SWI1210C-R15 □	150	60	50	300	800	0.18	800
SWI1210C-R18 □	180	60	50	300	760	0.21	800
SWI1210C-R22 □	220	60	50	300	660	0.27	800
SWI1210C-R27 □	270	50	50	300	600	0.33	700
SWI1210C-R33 □	330	50	50	100	550	0.37	650
SWI1210C-R39 □	390	50	50	100	500	0.63	600
SWI1210C-R47 □	470	50	50	100	450	0.69	550
SWI1210C-R56 □	560	50	50	100	400	0.90	450
SWI1210C-R68 □	680	50	25	100	380	1.05	400
SWI1210C-R82 □	820	50	25	100	350	1.45	350
SWI1210C-1R0 □	1000	45	25	100	300	1.90	280
SWI1210C-1R2 □	1200	45	7.96	50	300	2.20	250
SWI1210C-1R5 □	1500	45	7.96	50	250	2.43	220
SWI1210C-1R8 □	1800	45	7.96	50	200	3.36	180
SWI1210C-2R2 □	2200	40	7.96	50	200	3.50	150

RF Wire Wound Inductor- SWI-L Series

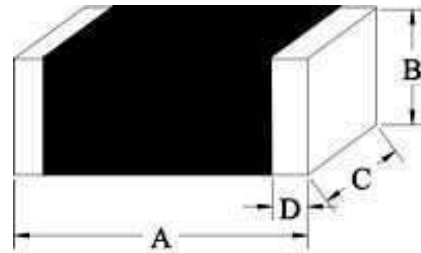
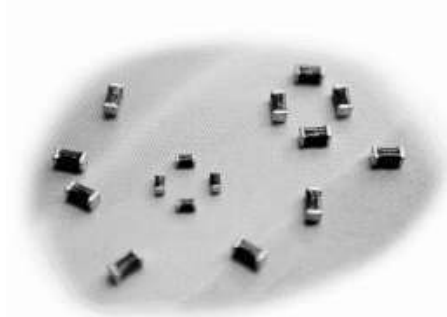

Features

- SWI-L Series are laser trimmed inductors used in communications
- Wide range of inductance values available for variable needs
- Excellent solderability and resistance to soldering heat

Dimensions

Part No.	A	B	C	D
SWI0402L	1.00 ± 0.10	0.50 ± 0.10	0.50 ± 0.10	0.20 ± 0.10
SWI0603L	1.60 ± 0.20	0.80 ± 0.20	0.80 ± 0.20	0.30 ± 0.10

Ordering Information

SWI 0402L-47N J

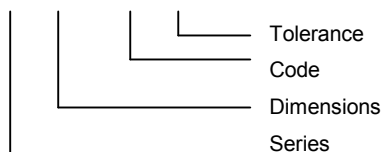

TYPE	SWI0402L	SWI0603L
QTY/REEL	10000pcs.	3000pcs.

Characteristics-SWI0402L

All Series: Tolerance: S = ± 0.3nH; G = ± 2%; J = ± 5%

Part No.	Inductance (nH)	Q Typical		Test Frequency (MHz)	SRF Min. (MHz)	RDC Max. (Ω)	IDC Max. (mA)
		100 MHz	800 MHz				
SWI0402L-1N0S	1.0	8	21	100	6000	0.05	400
SWI0402L-1N2S	1.2	8	21	100	6000	0.06	400
SWI0402L-1N5S	1.5	8	21	100	6000	0.07	400
SWI0402L-1N8S	1.8	8	21	100	6000	0.08	400
SWI0402L-2N2S	2.2	8	21	100	6000	0.09	400
SWI0402L-2N7S	2.7	8	21	100	5500	0.10	400
SWI0402L-3N3S	3.3	8	21	100	5500	0.12	400
SWI0402L-3N9S	3.9	8	20	100	5200	0.15	360
SWI0402L-4N7S	4.7	8	20	100	4800	0.17	360
SWI0402L-5N6S	5.6	8	20	100	4600	0.19	340
SWI0402L-6N8 □	6.8	8	19	100	4000	0.30	320
SWI0402L-8N2 □	8.2	8	19	100	3500	0.35	320
SWI0402L-10N □	10	8	19	100	2800	0.41	320
SWI0402L-12N □	12	8	19	100	2800	0.45	320
SWI0402L-15N □	15	8	19	100	2500	0.60	240
SWI0402L-18N □	18	8	19	100	2200	0.70	240
SWI0402L-22N □	22	8	19	100	2000	0.80	200
SWI0402L-27N □	27	8	19	100	1800	1.20	200
SWI0402L-33N □	33	8	18	100	1800	1.40	170
SWI0402L-39N □	39	8	18	100	1800	1.70	150
SWI0402L-47N □	47	8	17	100	1800	2.10	140
SWI0402L-56N □	56	8	17	100	1500	2.50	130
SWI0402L-68N □	68	8	15	100	1500	4.00	120
SWI0402L-82N □	82	8	15	100	1400	4.50	110
SWI0402L-R10 □	100	8	14	100	1200	5.50	90



Characteristics-SWI0603L

Part No.	Inductance (nH)	Q (min) @ 1000MHz	Test Frequency (MHz)	SRF Min. (MHz)	RDC Max. (Ω)	IDC Max. (mA)
SWI0603L-1N0S	1.0	30	100	6000	0.06	500
SWI0603L-1N2S	1.2	30	100	6000	0.06	500
SWI0603L-1N5S	1.5	30	100	6000	0.07	500
SWI0603L-1N8S	1.8	30	100	6000	0.08	500
SWI0603L-2N2S	2.2	30	100	6000	0.09	500
SWI0603L-2N7S	2.7	30	100	6000	0.10	500
SWI0603L-3N3S	3.3	30	100	5500	0.12	500
SWI0603L-3N9S	3.9	30	100	5500	0.15	450
SWI0603L-4N7S	4.7	30	100	4800	0.17	450
SWI0603L-5N6S	5.6	30	100	4600	0.18	430
SWI0603L-6N8 □	6.8	30	100	3550	0.20	430
SWI0603L-8N2 □	8.2	30	100	3500	0.28	400
SWI0603L-10N □	10	30	100	2800	0.32	400
SWI0603L-12N □	12	30	100	2800	0.35	400
SWI0603L-15N □	15	30	100	2500	0.41	350
SWI0603L-18N □	18	30	100	2300	0.45	350
SWI0603L-22N □	22	30	100	2000	0.50	300
SWI0603L-27N □	27	30	100	2000	0.55	300
SWI0603L-33N □	33	30	100	1800	0.60	300
SWI0603L-39N □	39	30	100	1800	0.80	300
SWI0603L-47N □	47	30	100	1800	0.95	250
SWI0603L-56N □	56	30	100	1800	1.20	250
SWI0603L-68N □	68	30	100	1500	1.30	250
SWI0603L-82N □	82	30	100	1500	1.50	250
SWI0603L-R10 □	100	26	100	1300	1.80	200
SWI0603L-R12 □	120	26	100	1200	3.00	130
SWI0603L-R15 □	150	26	100	1100	4.50	100
SWI0603L-R18 □	180	20	100	1000	6.50	80
SWI0603L-R22 □	220	20	100	900	7.50	70

SMD Air Coil- SAS Series

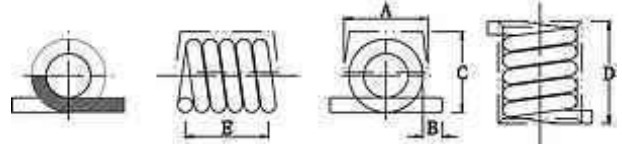

Features

- Low cost inductors
- High frequency
- Highest possible SRF's as well as excellent quality factor values

Dimensions

Part No.	A	B	C	D	E
SAS291A Series	3.05 Max.	0.58 ± 0.38	3.18 Max.	3.68 Max.	2.92 ± 0.25
SAS291B Series	3.05 Max.	0.58 ± 0.38	3.18 Max.	6.86 Max.	5.84 ± 0.25

Ordering Information

SAS 291 A 01

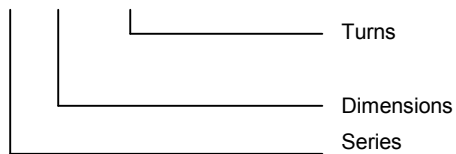

Characteristics

Part No.	Turns	Inductance (nH)	Q	Test Frequency (MHz)	SRF Min. (GHz)
SAS291A-01	1	2.5 ± 10%	143	150	>3
SAS291A-02	2	5.0 ± 10%	140	150	>3
SAS291A-03	3	8.0 ± 5%	139	150	>3
SAS291A-04	4	12.5 ± 5%	138	150	>3
SAS291A-05	5	18.5 ± 5%	133	150	>3
SAS291B-06	6	17.5 ± 5%	100	150	>3
SAS291B-07	7	22.0 ± 5%	103	150	>3
SAS291B-08	8	28.0 ± 5%	104	150	>2.6
SAS291B-09	9	35.5 ± 5%	108	150	>1.8
SAS291B-10	10	43.5 ± 5%	108	150	>1.5

Axial Choke – SEC Series

SCHMID-M

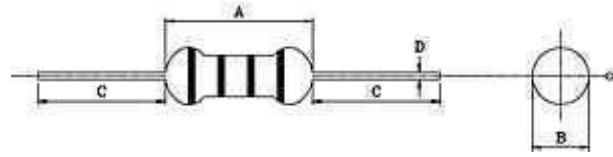
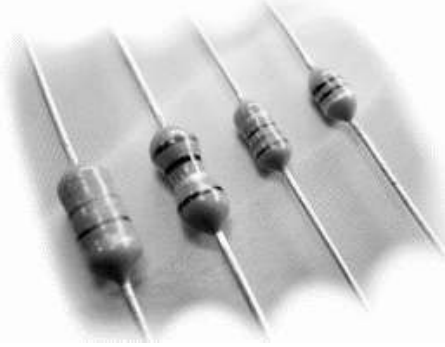

Features

- High-performance core and small choke coils which allow over 1000 μ H
- Epoxy resin coating ensures humidity resistance for long life
- Compact, small and light-weight design
- Conformal coated inductors

Ordering Information

SEC 22-4R7 M

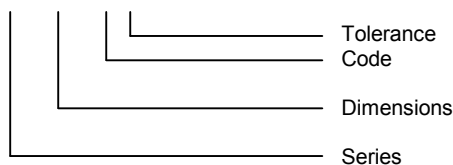

Dimensions

Part No.	A	B	C	D
SEC22	5.0 Max.	2.8 Max.	29.5 \pm 3.0	0.5 \pm 0.05
SEC24	8.0 Max.	3.0 Max.	28.0 \pm 3.0	0.6 \pm 0.05
SEC36	10.0 Max.	4.0 Max.	26.0 \pm 3.0	0.7 \pm 0.05
SEC46	12.0 Max.	5.0 Max.	26.0 \pm 3.0	0.7 \pm 0.05

Part No.	SEC22	SEC24	SEC36	SEC46
QTY/REEL	5000pcs.	5000pcs.	5000pcs.	3000pcs.
QTY/BOX	2000pcs.	2000pcs.	1000pcs.	500pcs.

Characteristics-SEC22

All Series: Tolerance: J = \pm 5%; K = \pm 10%; M = \pm 20%

Part No.	Inductance (μ H)	Q (min)	Test Frequency (MHz)	SRF Min. (MHz)	RDC Max. (Ω)	IDC Max. (mA)
SEC22-R10 \square	0.10	35	25.2	300	0.180	700
SEC22-R12 \square	0.12	35	25.2	300	0.200	660
SEC22-R15 \square	0.15	35	25.2	300	0.220	620
SEC22-R18 \square	0.18	35	25.2	300	0.240	600
SEC22-R22 \square	0.22	35	25.2	150	0.400	400
SEC22-R27 \square	0.27	35	25.2	150	0.430	380
SEC22-R33 \square	0.33	35	25.2	150	0.480	370
SEC22-R39 \square	0.39	35	25.2	150	0.510	350
SEC22-R47 \square	0.47	35	25.2	150	0.560	330
SEC22-R56 \square	0.56	35	25.2	150	0.610	320
SEC22-R68 \square	0.68	35	25.2	150	0.670	310
SEC22-R82 \square	0.82	35	25.2	150	0.740	290
SEC22-1R0 \square	1.00	35	25.2	150	0.800	270
SEC22-1R2 \square	1.20	40	7.96	110	0.900	260
SEC22-1R5 \square	1.50	40	7.96	70	1.000	250
SEC22-1R8 \square	1.80	40	7.96	60	1.100	240
SEC22-2R2 \square	2.20	40	7.96	45	1.200	230
SEC22-2R7 \square	2.70	40	7.96	40	1.300	220
SEC22-3R3 \square	3.30	40	7.96	38	1.400	210
SEC22-3R9 \square	3.90	40	7.96	36	1.500	200
SEC22-4R7 \square	4.70	40	7.96	32	1.700	190
SEC22-5R6 \square	5.60	40	7.96	30	1.900	180
SEC22-6R8 \square	6.80	40	7.96	28	2.000	175
SEC22-8R2 \square	8.20	40	7.96	26	2.200	165
SEC22-100 \square	10	40	7.96	24	2.500	160
SEC22-120 \square	12	40	2.52	22	2.500	150
SEC22-150 \square	15	40	2.52	20	2.800	145
SEC22-180 \square	18	40	2.52	18	3.100	140
SEC22-220 \square	22	40	2.52	17	3.400	100
SEC22-270 \square	27	40	2.52	16	4.300	80



Part No.	Inductance (μ H)	Q (min)	Test Frequency (MHz)	SRF Min. (MHz)	RDC Max. (Ω)	IDC Max. (mA)
SEC22-330 □	33	40	2.52	14	4.700	75
SEC22-390 □	39	40	2.52	13	5.200	74
SEC22-470 □	47	40	2.52	12	5.800	70
SEC22-560 □	56	40	2.52	11	6.400	68
SEC22-680 □	68	40	2.52	10	7.200	64
SEC22-820 □	82	40	2.52	9.5	11.00	46
SEC22-101 □	100	40	2.52	9.0	12.00	44
SEC22-121 □	120	40	0.796	8.0	13.00	42
SEC22-151 □	150	40	0.796	6.0	16.00	39
SEC22-181 □	180	40	0.796	5.0	18.00	37
SEC22-221 □	220	40	0.796	5.0	20.00	35
SEC22-271 □	270	40	0.796	4.6	25.00	25
SEC22-331 □	300	40	0.796	4.2	30.00	25
SEC22-391 □	390	40	0.796	3.8	34.00	25
SEC22-471 □	470	40	0.796	3.5	38.00	24

Characteristics-SEC24

Part No.	Inductance (μ H)	Q (min)	Test Frequency (MHz)	SRF Min. (MHz)	RDC Max. (Ω)	IDC Max. (mA)
SEC24-R10 □	0.10	40	25.2	480	0.060	1400
SEC24-R12 □	0.12	40	25.2	450	0.060	1350
SEC24-R15 □	0.15	40	25.2	420	0.070	1270
SEC24-R18 □	0.18	40	25.2	400	0.070	1200
SEC24-R22 □	0.22	40	25.2	380	0.080	1150
SEC24-R27 □	0.27	40	25.2	360	0.085	1110
SEC24-R33 □	0.33	40	25.2	350	0.095	1110
SEC24-R39 □	0.39	40	25.2	320	0.100	1000
SEC24-R47 □	0.47	40	25.2	300	0.110	1000
SEC24-R56 □	0.56	40	25.2	280	0.120	950
SEC24-R68 □	0.68	40	25.2	250	0.130	900
SEC24-R82 □	0.82	40	25.2	200	0.140	900
SEC24-1R0 □	1.00	40	25.2	180	0.150	815
SEC24-1R2 □	1.20	40	7.96	165	0.180	740
SEC24-1R5 □	1.50	40	7.96	150	0.200	700
SEC24-1R8 □	1.80	50	7.96	125	0.230	655
SEC24-2R2 □	2.20	50	7.96	110	0.250	630
SEC24-2R7 □	2.70	50	7.96	95	0.280	595
SEC24-3R3 □	3.30	50	7.96	70	0.300	575
SEC24-3R9 □	3.90	50	7.96	65	0.320	555
SEC24-4R7 □	4.70	50	7.96	50	0.350	530
SEC24-5R6 □	5.60	50	7.96	40	0.400	500
SEC24-6R8 □	6.80	50	7.96	30	0.450	470
SEC24-8R2 □	8.20	50	7.96	28	0.560	425
SEC24-100 □	10	50	7.96	22	0.750	370
SEC24-120 □	12	50	2.52	20	0.800	350
SEC24-150 □	15	50	2.52	16	0.930	335
SEC24-180 □	18	50	2.52	15	1.000	315
SEC24-220 □	22	50	2.52	13	1.200	285
SEC24-270 □	27	50	2.52	11	1.800	270
SEC24-330 □	33	50	2.52	10	2.100	255
SEC24-390 □	39	50	2.52	9.5	2.300	240
SEC24-470 □	47	50	2.52	8.5	2.600	205
SEC24-560 □	56	50	2.52	7.5	2.900	195
SEC24-680 □	68	50	2.52	6.5	3.300	185
SEC24-820 □	82	50	2.52	6.0	3.800	175
SEC24-101 □	100	50	2.52	5.5	4.200	165
SEC24-121 □	120	60	0.796	5.4	4.700	160
SEC24-151 □	150	60	0.796	4.7	5.400	150
SEC24-181 □	180	60	0.796	4.3	6.000	140
SEC24-221 □	220	60	0.796	4.0	7.000	130
SEC24-271 □	270	60	0.796	3.7	7.700	120
SEC24-331 □	330	60	0.796	3.4	11.100	100
SEC24-391 □	390	60	0.796	2.8	12.600	95
SEC24-102 □	1000	50	0.796	1.2	31.400	60



Characteristics-SEC36

Part No.	Inductance (µH)	Q (min)	Test Frequency (MHz)	SRF Min. (MHz)	RDC Max. (Ω)	IDC Max. (mA)
SEC36-R10 □	0.10	25	25.2	480	0.060	1700
SEC36-R12 □	0.12	25	25.2	450	0.060	1640
SEC36-R15 □	0.15	25	25.2	420	0.070	1560
SEC36-R18 □	0.18	25	25.2	400	0.070	1480
SEC36-R22 □	0.22	25	25.2	380	0.080	1400
SEC36-R27 □	0.27	25	25.2	340	0.085	1320
SEC36-R33 □	0.33	25	25.2	300	0.095	1280
SEC36-R39 □	0.39	25	25.2	280	0.120	1200
SEC36-R47 □	0.47	25	25.2	250	0.130	1150
SEC36-R56 □	0.56	25	25.2	230	0.140	1100
SEC36-R68 □	0.68	25	25.2	210	0.150	1030
SEC36-R82 □	0.82	45	25.2	172	0.160	980
SEC36-1R0 □	1.00	45	25.2	157	0.170	920
SEC36-1R2 □	1.20	50	7.96	144	0.180	880
SEC36-1R5 □	1.50	50	7.96	131	0.200	830
SEC36-1R8 □	1.80	55	7.96	121	0.220	790
SEC36-2R2 □	2.20	55	7.96	110	0.240	750
SEC36-2R7 □	2.70	60	7.96	100	0.250	720
SEC36-3R3 □	3.30	65	7.96	94	0.300	670
SEC36-3R9 □	3.90	65	7.96	86	0.350	640
SEC36-4R7 □	4.70	70	7.96	80	0.400	620
SEC36-5R6 □	5.60	70	7.96	74	0.450	590
SEC36-6R8 □	6.80	75	7.96	68	0.500	550
SEC36-8R2 □	8.20	80	7.96	53	0.600	530
SEC36-100 □	10	80	7.96	45	0.650	500
SEC36-120 □	12	75	2.52	34	0.700	480
SEC36-150 □	15	70	2.52	20	0.750	460
SEC36-180 □	18	65	2.52	14	0.800	430
SEC36-220 □	22	50	2.52	9.9	0.900	410
SEC36-270 □	27	55	2.52	7.6	1.000	390
SEC36-330 □	33	55	2.52	6.3	1.100	370
SEC36-390 □	39	50	2.52	6.3	1.200	350
SEC36-470 □	47	45	2.52	6.3	1.300	340
SEC36-560 □	56	40	2.52	6.2	1.500	320
SEC36-680 □	68	40	2.52	5.7	1.800	305
SEC36-820 □	82	35	2.52	5.3	2.000	290
SEC36-101 □	100	30	2.52	4.8	2.500	275
SEC36-121 □	120	70	0.796	3.8	3.000	185
SEC36-151 □	150	70	0.796	3.5	4.200	175
SEC36-181 □	180	70	0.796	3.3	4.600	165
SEC36-221 □	220	70	0.796	3.0	5.100	155
SEC36-271 □	270	65	0.796	2.8	6.000	145
SEC36-331 □	330	65	0.796	2.6	6.500	137
SEC36-391 □	390	65	0.796	2.4	7.500	133
SEC36-471 □	470	60	0.796	2.2	8.500	126
SEC36-561 □	560	60	0.796	2.1	9.500	120
SEC36-681 □	680	55	0.796	1.9	12.00	113
SEC36-821 □	820	55	0.796	1.8	14.00	105
SEC36-102 □	1000	50	0.796	1.4	20.00	85

Characteristics-SEC46

Part No.	Inductance (µH)	Q (min)	Test Frequency (MHz)	SRF Min. (MHz)	RDC Max. (Ω)	IDC Max. (mA)
SEC46-152 □	1.5	60	1.0	252	16.5	120
SEC46-222 □	2.2	60	1.0	252	27.5	120
SEC46-392 □	3.9	50	1.0	252	53	60
SEC46-472 □	4.7	50	1.0	252	60	60
SEC46-822 □	8.2	30	1.0	252	80	60
SEC46-103 □	10	25	1.0	79.6	132	30
SEC46-153 □	15	25	1.0	79.6	166	30
SEC46-223 □	22	20	1.0	79.6	330	15
SEC46-333 □	33	20	1.0	79.6	426	15
SEC46-393 □	39	20	1.0	79.6	473	15



Leaded Wire Wound Inductor – SPK Series

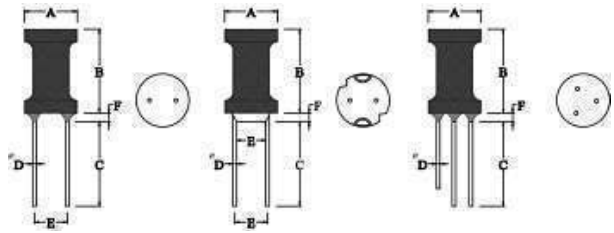

Features

- Designed for power supply with high reliability and saturation
- High current rating for high current circuits
- Designed by special lead wire to prevent open circuit failure

Dimensions

Part No.	SPK0406	SPK0608	SPK0810	SPK0912	SPK1016
A	5.5 Max.	7.5 Max.	9.5 Max.	10.5 Max.	11.5 Max.
B	7.5 Max.	9.5 Max.	11.5 Max.	13.5 Max.	17.5 Max.
C	16.0 ± 3.0	16.0 ± 3.0	16.0 ± 3.0	16.0 ± 3.0	16.0 ± 3.0
D	0.50 ± 0.05	0.65 ± 0.05	0.65 ± 0.05	0.80 ± 0.05	0.80 ± 0.05
E	2.0 ± 0.05	3.0 ± 0.05	5.0 ± 0.05	6.0 ± 0.05	6.0 ± 0.05
F	3.0 Max.	3.0 Max.	3.0 Max.	3.0 Max.	3.0 Max.

Ordering Information

SPK □ 0608-4R7 K

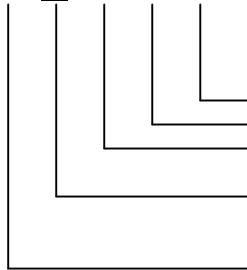

Tolerance Code
Dimensions

B-Base; A-Axial; S-Salient,
3W-3 Lead Wires

Series

TYPE	SPK0406	SPK0608	SPK0810	SPK0912	SPK1016
PE Bag	500pcs.	500pcs.	250pcs.	250pcs.	250pcs.

Characteristics

Tolerance: K = ± 10%; K tolerance is Standard.

Code	L (µH)	SPK0406		SPK0608		SPK0810		SPK0912		SPK1016	
		RDC Max. (Ω)	IDC Max. (A)	RDC Max. (Ω)	IDC Max. (A)	RDC Max. (Ω)	IDC Max. (A)	RDC Max. (Ω)	IDC Max. (A)	RDC Max. (Ω)	IDC Max. (A)
100	10	0.10	1.70	0.04	3.00	0.03	5.30	0.03	7.50	0.02	10.00
120	12	0.14	1.50	0.05	3.00	0.04	4.70	0.03	7.20	0.02	9.50
150	15	0.13	1.38	0.06	2.60	0.04	4.40	0.03	6.50	0.02	8.20
180	18	0.15	1.27	0.07	2.40	0.05	3.90	0.04	5.60	0.02	7.60
220	22	0.18	1.10	0.08	2.30	0.05	3.50	0.04	5.30	0.03	7.00
270	27	0.20	1.05	0.09	2.10	0.06	3.30	0.05	4.70	0.05	6.00
330	33	0.24	0.93	0.12	1.90	0.07	3.00	0.06	4.20	0.05	5.60
390	39	0.31	0.85	0.17	1.70	0.07	2.70	0.08	3.90	0.06	5.00
470	47	0.35	0.80	0.19	1.50	0.08	2.50	0.09	3.50	0.06	4.60
560	56	0.42	0.72	0.20	1.40	0.11	2.30	0.09	3.20	0.07	4.20
680	68	0.47	0.66	0.23	1.30	0.12	2.00	0.11	3.00	0.08	3.90
820	82	0.55	0.60	0.33	1.15	0.16	1.80	0.14	2.70	0.09	3.60
101	100	0.68	0.53	0.38	1.05	0.18	1.70	0.19	2.40	0.13	3.20
121	120	0.91	0.51	0.38	0.95	0.25	1.55	0.21	2.20	0.15	2.90
151	150	1.06	0.42	0.49	0.78	0.29	1.35	0.24	2.00	0.17	2.60
181	180	1.31	0.41	0.76	0.77	0.34	1.23	0.27	1.80	0.19	2.40
221	220	1.72	0.35	0.87	0.70	0.38	1.15	0.35	1.70	0.25	2.20
271	270	2.07	0.32	0.98	0.65	0.48	1.00	0.48	1.50	0.34	1.90
331	330	2.44	0.28	1.15	0.58	0.59	0.92	0.55	1.36	0.38	1.70
391	390	2.65	0.26	1.27	0.52	0.77	0.84	0.60	1.26	0.41	1.60
471	470	2.91	0.24	1.63	0.47	0.92	0.74	0.84	1.12	0.48	1.50
561	560	3.27	0.23	2.44	0.44	1.02	0.72	0.93	1.00	0.65	1.35
681	680	4.93	0.19	2.75	0.38	1.31	0.65	1.06	0.92	0.93	1.26
821	820	5.53	0.18	3.09	0.36	1.46	0.58	1.31	0.85	1.04	1.15
102	1000	7.60	0.17	3.49	0.33	1.73	0.53	1.49	0.78	1.06	1.00

Wirewound Rodcore Inductor – SR Series

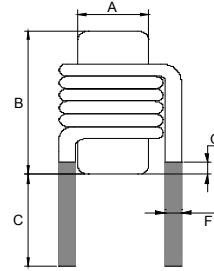

Features

- For high current
- Printed circuit mounting
- For switching regulators, power supplies, amplifiers, monitors, UPS, etc.

Ordering Information

SR 0410-5R6 K

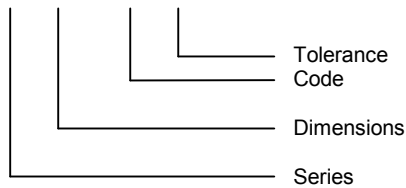

Characteristics & Dimensions

Part No.	A	B	C(min)	G(min)	Inductance (μH)	IDC (A)	Test Frequency (KHz)
SR0410	4.0 ± 0.3	10.0 ± 0.3	3.4	0.5	0.5 ~ 1.0	13	1
SR0415	4.0 ± 0.3	15.0 ± 0.3	3.4	0.5	0.5 ~ 1.2	15	1
SR0420	4.0 ± 0.3	20.0 ± 0.3	3.4	0.5	0.5 ~ 3.0	18	1
SR0515	5.0 ± 0.3	15.0 ± 0.3	3.4	0.5	0.5 ~ 4.0	18	1
SR0520	5.0 ± 0.3	20.0 ± 0.3	3.4	0.5	0.5 ~ 7.0	18	1
SR0525	5.0 ± 0.3	25.0 ± 0.3	3.4	0.5	0.5 ~ 10	18	1
SR0610	6.0 ± 0.3	10.0 ± 0.3	3.4	0.5	0.5 ~ 1.5	18	1
SR0615	6.0 ± 0.3	15.0 ± 0.3	3.4	0.5	0.5 ~ 5.0	18	1
SR0620	6.0 ± 0.3	20.0 ± 0.3	3.4	0.5	0.8 ~ 5.0	18	1
SR0625	6.0 ± 0.3	25.0 ± 0.3	3.4	0.5	1.0 ~ 27	15	1
SR0630	6.0 ± 0.3	30.0 ± 0.3	3.4	0.5	1.0 ~ 22	18	1
SR0820	8.0 ± 0.3	20.0 ± 0.3	3.4	0.5	1.0 ~ 33	18	1

Toroidal Line Choke – STI Series

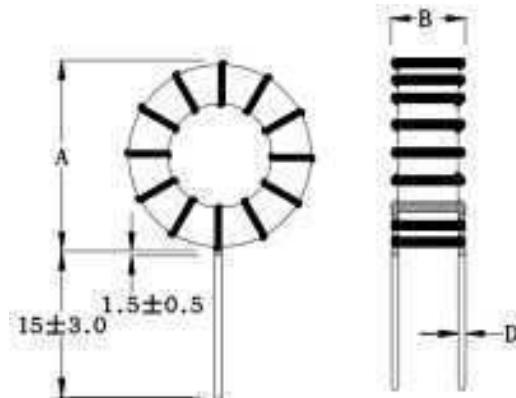

Features

- Coated with varnish
- High saturation current
- Excellent high current rating

Ordering Information

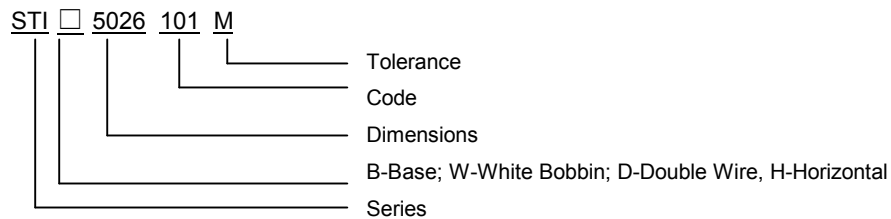

Characteristic

Part Code	L (µH)	STI4426 14,0*8,0*0,6mm		STI5026 16,0*8,0*0,6mm		STI6026 18,5*9,5*0,6mm		STI6826 20,5*8,5*0,7mm	
		RDC (Ω)	IDC (A)	RDC (Ω)	IDC (A)	RDC (Ω)	IDC (A)	RDC (Ω)	IDC (A)
220	22	0.04	2.50	0.03	3.50	0.02	4.50	0.01	5.00
330	33	0.09	2.00	0.04	2.60	0.03	4.00	0.03	4.10
470	47	0.10	1.80	0.04	2.20	0.05	3.20	0.04	3.60
680	68	0.16	1.40	0.05	1.90	0.06	2.50	0.06	2.80
820	82	0.14	1.30	0.06	1.80	0.10	2.40	0.07	2.40
101	100	0.15	1.30	0.07	1.50	0.11	2.20	0.06	2.00
121	120	0.16	1.10	0.09	1.40	0.15	2.00	0.07	2.00
151	150	0.20	0.95	0.12	1.20	0.10	1.60	0.07	1.60
221	220	0.30	0.90	0.21	0.90	0.12	1.40	0.12	1.40
331	330	0.45	0.70	0.30	0.84	0.21	1.00	0.21	1.20
471	470	0.83	0.60	0.47	0.70	0.33	0.95	0.32	1.00

Other parts are available on request.

Flat Inductor – SFC Series

SCHMID-M

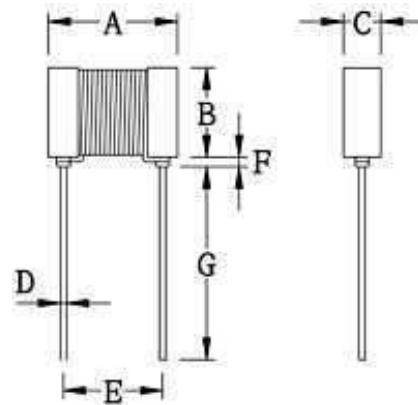
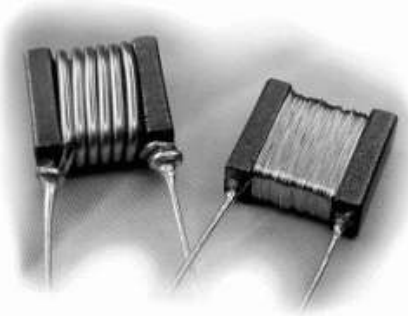

Features

- Low cost
- High quality factor radial lead inductors
- Unique configuration makes this series ideally suited for use in high density PCB

Dimensions

Part No.	A	B	C	
SFC108938	10 ± 0.25	9.0 Max.	4.0 Max.	
	D	E	F	G
	0.5 ± 0.05	7.62 ± 0.5	3.0 Max.	5.0 Min.

Ordering Information

SFC 108938-4R7 K

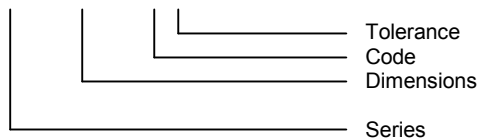

Characteristics

Part No.	L (µH)	Q (min)	Test Frequency (MHz)	RDC (Ω)	IDC (A)
SFC108938-1R0K	1.0	37	7.9	0.010	7.00
SFC108938-1R2K	1.2	39	7.9	0.012	6.00
SFC108938-1R5K	1.5	33	7.9	0.014	5.00
SFC108938-1R8K	1.8	37	7.9	0.020	4.80
SFC108938-2R2K	2.2	38	7.9	0.025	4.40
SFC108938-2R7K	2.7	43	7.9	0.028	4.00
SFC108938-3R3K	3.3	35	7.9	0.036	3.70
SFC108938-3R9K	3.9	37	7.9	0.050	3.40
SFC108938-4R7K	4.7	37	7.9	0.053	3.20
SFC108938-5R6K	5.6	35	7.9	0.092	2.80
SFC108938-6R8K	6.8	29	7.9	0.113	2.60
SFC108938-8R2K	8.2	32	7.9	0.116	2.20
SFC108938-100K	10	31	7.9	0.120	2.10
SFC108938-120K	12	55	7.9	0.140	2.00
SFC108938-150K	15	51	7.9	0.158	1.60
SFC108938-180K	18	46	7.9	0.180	1.50
SFC108938-220K	22	51	7.9	0.230	1.40
SFC108938-270K	27	52	7.9	0.265	1.30
SFC108938-330K	33	47	7.9	0.346	1.20
SFC108938-390K	39	46	7.9	0.371	1.10
SFC108938-470K	47	45	7.9	0.502	1.03
SFC108938-560K	56	45	7.9	0.687	0.95
SFC108938-680K	68	46	7.9	0.888	0.90
SFC108938-820K	82	53	7.9	1.196	0.85
SFC108938-101K	100	39	7.9	1.495	0.80

Tolerance: K = ± 10%, K tolerance is standard.

Leaded Line Filter – SQT02 Series

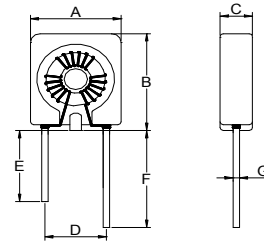
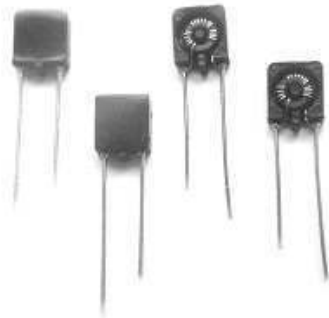

Features

- Unique configuration
- Ideal for EMI countermeasures
- Shapes and dimensions follow E.I.A. Spec.
- Excellent soldering ability and heat resistance
- High reliability

Ordering Information

SQT-02 251

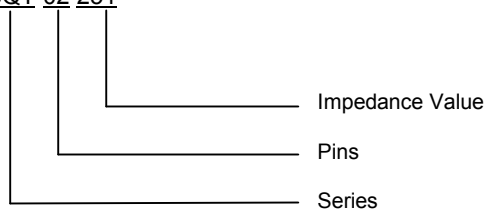

Dimensions

Part No.	A	B	C	D	E	F	G
SQT-02	8.0 Max.	9.5 Max.	3.5 Max.	4.5 ± 0.5	15.0 ± 0.10	19.0 ± 0.15	0.6 REF

Characteristics

Part No.	Inductance (μ H) @1KHz/1.0V	Impedance (Ω) Min.	Rated Voltage (V)	DC Resistance (m Ω) Max.	IDC (A)	Test Frequency (MHz)
SQT-02251	4.7	250	50	20	0.20	100
SQT-02401	8.2	400	50	25	0.20	100
SQT-02501	33	500	50	35	0.50	100
SQT-02801	40	800	50	40	0.50	100
SQT-02122	60	1200	50	58	0.50	100
SQT-02152	80	1500	50	62	0.50	100
SQT-02172	100	1700	50	95	0.50	100
SQT-02202	120	2000	50	100	0.50	100

Leaded Common Choke – SQT-04 Series

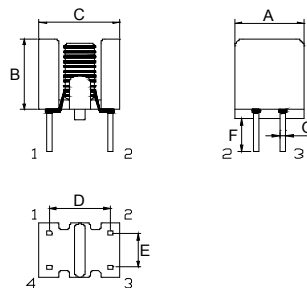
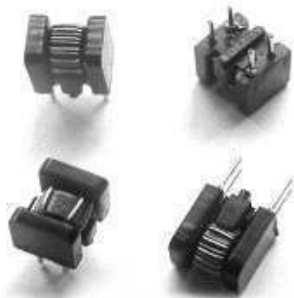

Features

- Unique configuration
- Ideal for EMI countermeasures
- Shapes and dimensions follow E.I.A. Spec.
- Excellent soldering ability and heat resistance
- High reliability

Ordering Information

SQT-04 40

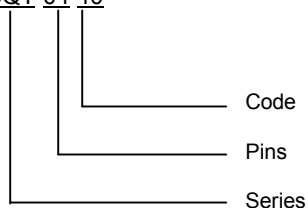

Dimensions

Part No.	A	B	C	D	E	F	G
SQT-04	6.0 ± 0.3	7.2 ± 0.3	7.0 ± 0.3	5.08 ± 0.5	2.5 ± 0.3	3.5 ± 0.5	0.6 REF

Characteristics

Part No.	Inductance (µH)	Impedance (Ω) Min.	Rated Voltage (V)	DC Resistance (mΩ) Max.	Rated Current (A)	Test Frequency (MHz)
SQT-04201	15	200	50	35	0.50	100
SQT-04501	40	500	50	40	0.50	100
SQT-04701	60	700	50	50	0.50	100
SQT-04102	80	1000	50	60	0.50	100

Current Compensated Chokes – SCC Series

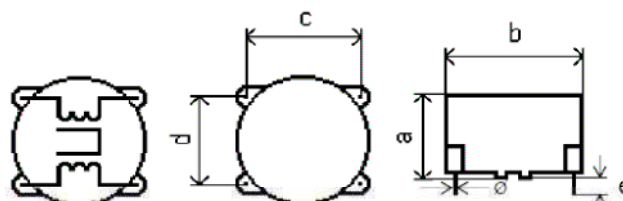

Series	a	b	c	d	Pins
MH	12,5	17,5	15,0	10,0	0,6*0,6
SH	14,0	22,5	20,0	12,5	0,6*0,6
VH	16,5	28,0	25,0	15,0	0,6*0,6
NH	19,5	32,5	30,0	20,0	0,8*0,8

Features

- Ideal for RFI suppression of appliances and machines
- High permeability ferrite toroids with two symmetrical windings
- Easy mounting with the 4 pins housing
- Excellent soldering ability and heat resistance
- High reliability

Ordering Information

SCC-MVx-102

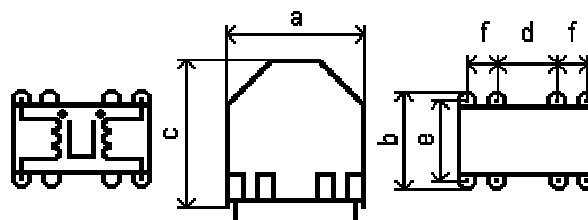
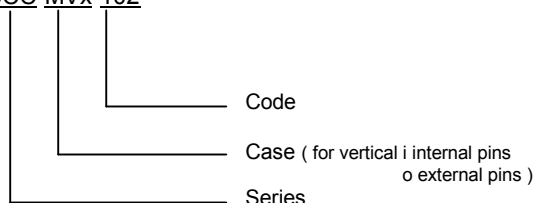

Series	a	b	c	d	e	f	Pins
MVx	18,0	13,0	20,0	5,0	10,0	5,0	0,6*0,6
SVx	23,0	15,5	25,0	10,0	12,5	5,0	0,6*0,6
VVx	26,0	18,0	30,0	12,5	15,0	5,0	0,6*0,6
NVx	32,0	21,0	35,0	12,5	17,5	7,5	0,8*0,8

Technical data

Application class	40/125/21
Nominal voltage	250V , 50Hz
Testing voltage (winding-winding)	1500V , 50Hz , 2sec.
Inductance tolerance	+ - 30%
Over temperature of the windings	< 55°C
Maximum admissible temperature of the windings	115°C

Characteristics

Part No.	102	332	682	103	183	333	473
MH / MVx	1mH/2,0A	3,3mH/1,5A	6,8mH/1,0A	10mH/0,7A	18mH/0,5A	33mH/0,4A	47mH/0,3A
SH / SVx	1mH/3,0A	3,3mH/2,0A	6,8mH/1,5A	10mH/1,2A	18mH/0,8A	33mH/0,5A	47mH/0,4A
VH / VVx	1mH/4,0A	3,3mH/2,8A	6,8mH/1,9A	10mH/1,5A	18mH/1,2A	33mH/0,8A	47mH/0,6A
NH / NVx	1mH/6,0A	3,3mH/4,0A	6,8mH/2,5A	10mH/1,8A	18mH/1,4A	33mH/1,0A	47mH/0,8A

SMD current-compensated choke - SCC – SMD series

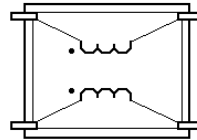
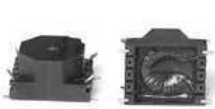

Recommended soldering areas

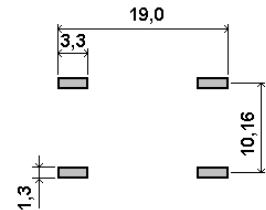
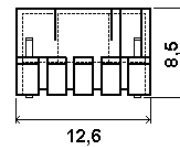
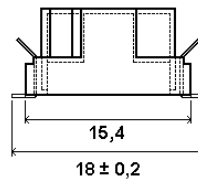

Features

- Ideal for RFI suppression of Appliances, switch sources and machines
- High permeability ferrite toroids with two symmetrical windings
- Easy mounting with the 4 pins housing
- Excellent soldering ability and heat resistance
- High reliability

Technical data

Climatic category	40/125/21
Nominal voltage	250V , 50Hz
Testing voltage	1500V , 50Hz , 2sec.
Inductance tolerance	+ - 30%
Overtemperature of the windings	< 55°C
Insulating resistance	50 MΩ, 500Vdc

Standard parts

	Inductance (mH)	DC Resistance (mOhm)	Rated Current (A)
SCC-SMD - 332	3,3	240	1,0
SCC-SMD - 103	10,0	600	0,6
SCC-SMD - 393	39,0	2900	0,3

Insertion loss of current compensated nanocrystalline choke

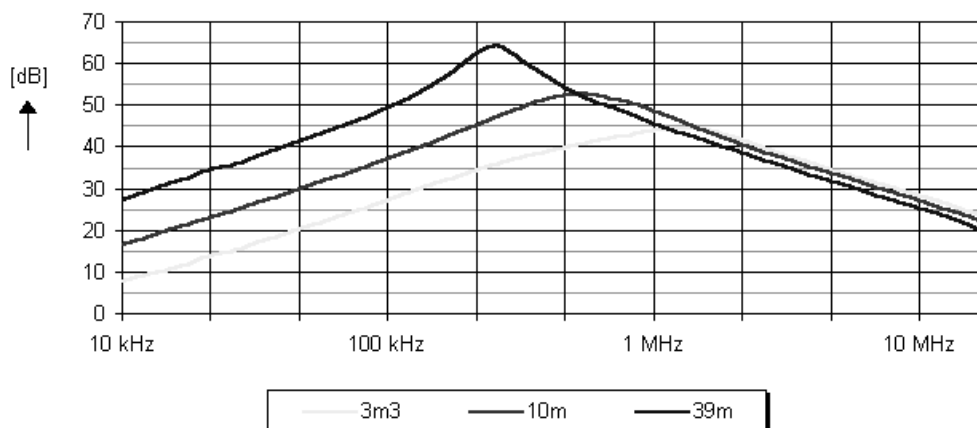



Current-compensated nanocrystalline chokes – SCCN Series

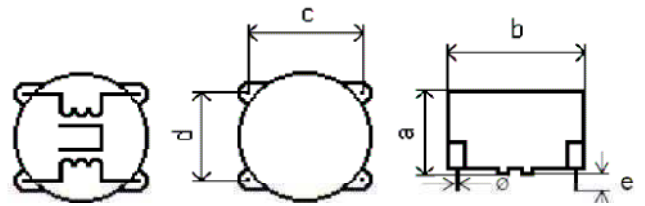
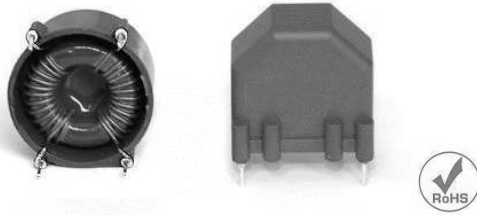

Series	a	b	c	d	Pins
VH	16,5	28,0	25,0	15,0	0,6*0,6
NH	19,5	32,5	30,0	20,0	0,8*0,8

Features

- are based on high permeability nanocrystalline toroids with two symmetrical windings
- Ideal mainly for RFI suppression of appliances and machines
- Excellent soldering ability and heat resistance
- current rating up to three times higher inductance than choke with ferrite core

Technical data

Climatic category	40/125/21
Nominal voltage	250V , 50Hz
Testing voltage	1500V , 50Hz , 2sec.
Inductance tolerance	+ - 40%
Over temperature of the windings	< 55°C
Insulating resistance	50 MΩ, 500Vdc

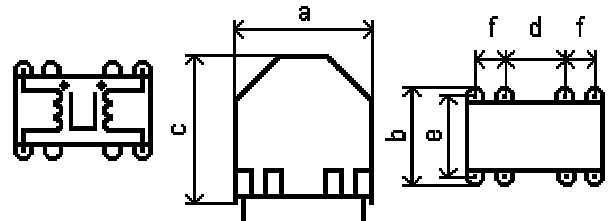

Series	a	b	c	d	e	f	Pins
VVx	26,0	18,0	30,0	12,5	15,0	5,0	0,6*0,6
NVx	32,0	21,0	35,0	12,5	17,5	7,5	0,8*0,8

o = external pins i = internal pins

Characteristics

	Inductance(mH)	DC Resistance (mOhm)	Rated Current (A)
SCCN-Vxx-123	12,0	60	3,0
SCCN-Vxx-183	18,0	120	2,0
SCCN-Vxx-333	33,0	200	1,6
SCCN-Vxx-683	68,0	425	1,0
SCCN-Vxx-124	120,0	900	0,7
SCCN-Nxx-123	12,0	30	6,0
SCCN-Nxx-183	18,0	60	4,0
SCCN-Nxx-333	33,0	105	3,0
SCCN-Nxx-683	68,0	180	2,2
SCCN-Nxx-124	120,0	300	1,7
SCCN-Nxx-224	220,0	725	1,0

Insertion loss of current compensated nanocrystalline choke

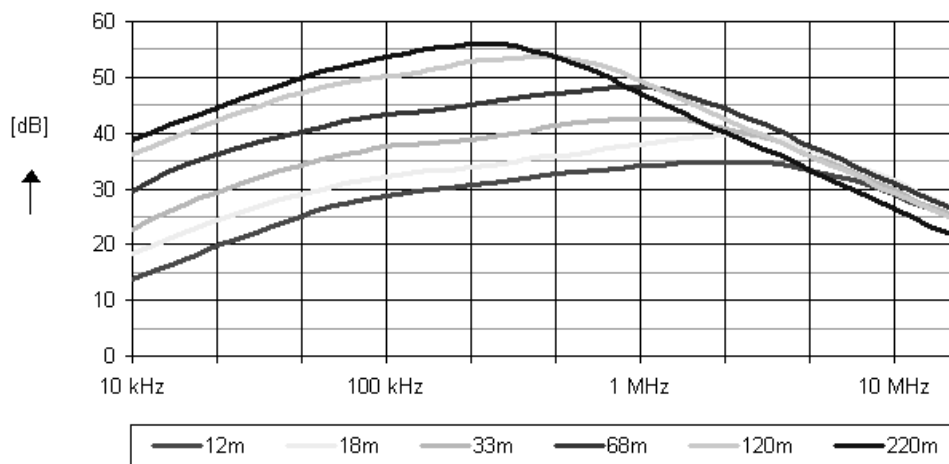

Current-compensated nanocrystalline choke – SCCON Series

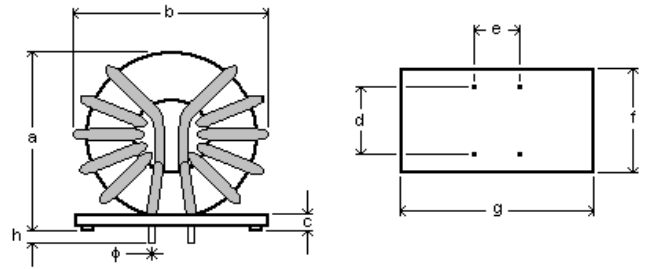

Features

- are based on high permeability nanocrystalline toroids with two symmetrical windings
- Ideal mainly for RFI suppression of Appliances and machines
- Excellent soldering ability and heat resistance
- Current rating up to three times higher inductance than choke with ferrite core

Series	a	b	c	d	e	f	g	Pins
SCCON	38,0	40,5	4,0	18,5	10,0	23,0	35,0	1,2

Technical data

Climatic category	40/125/21
Nominal voltage	250V , 50Hz
Testing voltage	1500V , 50Hz , 2sec.
Inductance tolerance	+ - 40%
Overtemperature of the windings	< 55°C
Insulating resistance	50 MΩ, 500Vdc

Standard parts

	Inductance(mH)	DC Resistance (mOhm)	Rated Current (A)
SCCON-V-502	5,0	10	13,0
SCCON-V-103	10,0	15	10,0
SCCON-V-153	15,0	25	8,0
SCCON-V-273	27,0	45	5,0

Insertion loss of current compensated nanocrystalline choke

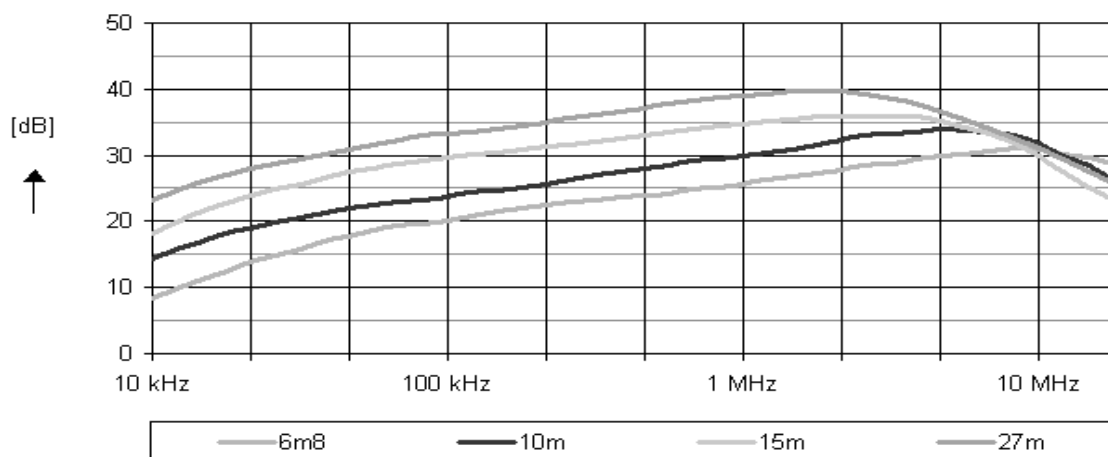

SMD Power Inductor – STP Series

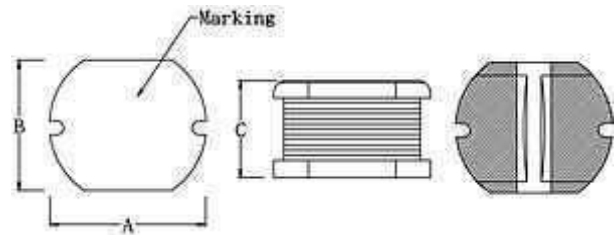

Features

- STP Series is superior to be high saturation for surface mounting
- High current rating for high current circuits
- Designed by special lead wire to prevent open circuit failure
- Excellent terminal strength construction

Ordering Information

STP 0302-4R7 K

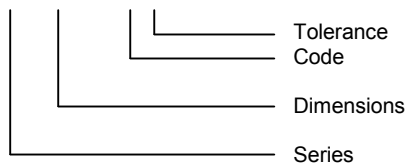

Dimensions

Part No.	A	B	C
STP0302	3.2 ± 0.30	2.8 ± 0.30	2.3 ± 0.30
STP0403	4.5 ± 0.30	4.0 ± 0.30	3.2 ± 0.30
STP0504	5.8 ± 0.30	5.2 ± 0.30	4.5 ± 0.35
STP0703	7.8 ± 0.30	7.0 ± 0.30	3.5 ± 0.50
STP0705	7.8 ± 0.30	7.0 ± 0.30	5.0 ± 0.50
STP1004	10 ± 0.30	9.0 ± 0.30	4.0 ± 0.50
STP1005	10 ± 0.40	9.0 ± 0.40	5.4 ± 0.40

Package

SIZE	STP0302	STP0403	STP0504	STP0703	STP0705	STP1004	STP1005
QTY/REEL	2000pcs.	1500pcs.	1500pcs.	1000pcs.	1000pcs.	1000pcs.	500pcs.



Code	L (μ H)	STP0302		STP0403		STP0504		STP0703		STP0705		STP1004		STP1005	
		RDC Max. (Ω)	IDC Max. (A)	RDC Max. (Ω)	IDC Max. (A)	RDC Max. (Ω)	IDC Max. (A)	RDC Max. (Ω)	IDC Max. (A)	RDC Max. (Ω)	IDC Max. (A)	RDC Max. (Ω)	IDC Max. (A)	RDC Max. (Ω)	IDC Max. (A)
1R0	1.0			0.049	2.560										
1R4	1.4			0.057	2.520										
1R5	1.5														
1R8	1.8			0.064	1.950										
2R2	2.2			0.072	1.750										
2R7	2.7			0.079	1.580										
3R3	3.3			0.087	1.440										
3R9	3.9			0.094	1.330										
4R7	4.7			0.109	1.150										
5R6	5.6			0.126	0.990										
6R8	6.8			0.132	0.950										
7R4	7.4														
8R2	8.2			0.147	0.840										
100	10	0.230	0.760	0.182	1.040	0.100	1.440	0.081	1.440	0.070	2.300	0.053	2.380	0.060	2.600
120	12	0.270	0.685	0.210	0.970	0.120	1.400	0.090	1.390	0.080	2.000	0.061	2.130	0.070	2.450
150	15	0.310	0.635	0.235	0.850	0.140	1.300	0.104	1.240	0.090	1.800	0.070	1.870	0.080	2.270
180	18	0.410	0.525	0.338	0.740	0.150	1.230	0.111	1.120	0.100	1.600	0.081	1.730	0.090	2.150
220	22	0.470	0.500	0.378	0.680	0.180	1.110	0.129	1.070	0.110	1.500	0.088	1.600	0.100	1.950
270	27	0.660	0.405	0.522	0.620	0.200	0.970	0.153	0.940	0.120	1.300	0.100	1.440	0.110	1.760
330	33	0.760	0.380	0.540	0.560	0.230	0.880	0.170	0.850	0.130	1.200	0.120	1.260	0.120	1.500
390	39	0.850	0.355	0.587	0.520	0.320	0.800	0.217	0.740	0.160	1.100	0.151	1.200	0.140	1.370
470	47	0.970	0.330	0.844	0.440	0.370	0.720	0.252	0.680	0.180	1.100	0.170	1.100	0.170	1.280
560	56	1.250	0.290	0.937	0.420	0.420	0.680	0.282	0.640	0.240	0.940	0.199	1.010	0.190	1.170
680	68	1.450	0.275	1.117	0.370	0.460	0.610	0.332	0.590	0.280	0.850	0.223	0.910	0.220	1.110
820	82	1.850	0.235			0.600	0.580	0.406	0.540	0.370	0.780	0.252	0.850	0.250	1.000
101	100	2.200	0.220			0.700	0.520	0.481	0.510	0.430	0.720	0.344	0.740	0.350	0.970
121	120	2.900	0.185			0.930	0.480	0.536	0.490	0.470	0.660	0.396	0.690	0.400	0.890
151	150	3.400	0.170			1.100	0.400	0.755	0.400	0.640	0.580	0.544	0.610	0.470	0.780
181	180	3.900	0.165			1.380	0.380	1.022	0.360	0.710	0.510	0.621	0.560	0.630	0.720
221	220	4.500	0.155			1.570	0.350	1.200	0.310	0.960	0.490	0.721	0.530	0.730	0.660
271	270	6.000	0.135					1.306	0.290	1.110	0.420	0.949	0.450	0.970	0.570
331	330	7.000	0.125					1.495	0.280	1.260	0.400	1.100	0.420	1.150	0.520
391	390	7.000	0.115							1.770	0.360	1.245	0.380	1.300	0.480
471	470									1.960	0.340	1.526	0.350	1.480	0.420
561	560											1.904	0.320	1.900	0.330
681	680													2.250	0.280
821	820													2.550	0.240
102	1000													2.750	0.220

SMD Power Inductor – SSPK Series

SCHMID-M

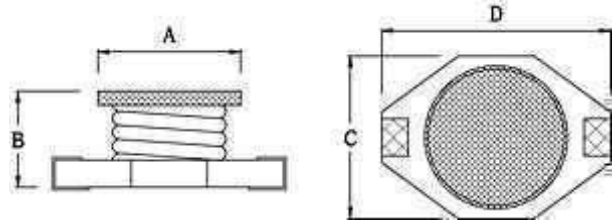
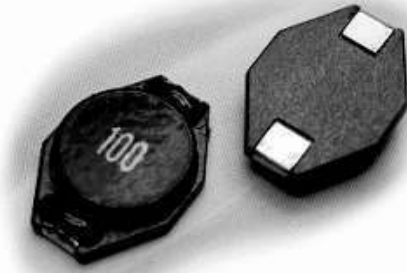

Features

- SSPK Series are designed for the smallest possible size and high performance, high storage and very low resistance
- Very small footprint
- Increased size selection guide
- Designed by special lead wire to prevent open circuit failure

Dimensions

Part No.	A	B	C	D
SSPK0802	8.6 Max.	3.0 Max.	9.5 Max.	13.5 Max.
SSPK0804	8.6 Max.	5.5 Max.	9.5 Max.	13.5 Max.
SSPK0810	8.6 Max.	11.5 Max.	9.5 Max.	13.5 Max.
SSPK1306	13.0 Max.	7.5 Max.	15.4 Max.	18.54 Max.

Ordering Information

SSPK 0802 100 M

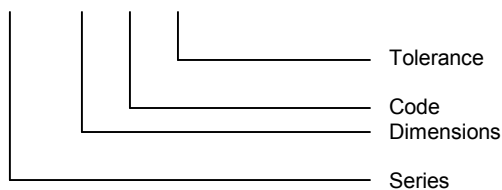

SSPK0802	SSPK0804	SSPK0810	SSPK1306
1000pcs.	1000pcs.	250pcs.	250pcs.

Characteristics

Tolerance: M = $\pm 20\%$; N = $\pm 25\%$, M tolerance is standard.

Code	L (μH)	SSPK0802		SSPK0804		SSPK0810		SSPK1306	
		RDC Max. (Ω)	IDC Max. (A)	RDC Max. (Ω)	IDC Max. (A)	RDC Max. (Ω)	IDC Max. (A)	RDC Max. (Ω)	IDC Max. (A)
3R3	3.3			0.015	6.40				
4R7	4.7			0.018	5.40				
6R8	6.8			0.027	4.60				
100	10	0.110	2.40	0.038	3.80	0.040	8.00	0.031	10.00
150	15	0.150	2.00	0.046	3.00	0.050	7.00	0.036	8.00
220	22	0.230	1.60	0.085	2.60	0.066	5.50	0.047	7.00
330	33	0.300	1.40	0.100	2.00	0.080	4.00	0.066	5.50
470	47	0.390	1.00	0.140	1.60	0.110	3.80	0.086	4.50
680	68	0.660	0.90	0.200	1.40	0.170	3.00	0.130	3.50
101	100	0.840	0.70	0.280	1.20	0.220	2.50	0.190	3.00
151	150			0.400	1.00	0.340	2.00	0.250	2.60
221	220			0.610	0.80	0.440	1.60	0.380	2.40
331	330			1.020	0.60	0.700	1.20	0.560	1.90
471	470			1.270	0.50	0.950	1.00	0.850	1.40
681	680					1.200	1.00	1.100	1.20
102	1000					2.000	0.80	1.800	1.00

Test Frequency 100KHz

SMD Power Inductor – SDO Series

SCHMID-M

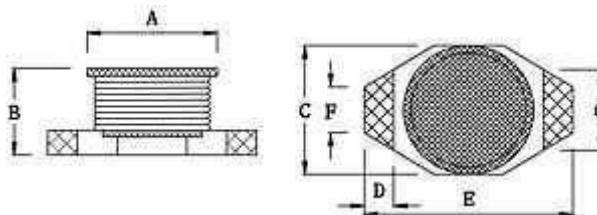

Features

- Inductance is from 1 μ H to 1000 μ H
- Designed for smallest possible size
- High energy storage and very low resistance
- Mighty temperature deflection prevents damage during solder reflow

Dimensions

Part No.	A	B	C	D	E	F	G
SDO0402	3.94 \pm 0.05	2.92 Max.	4.45 Max.	1.02 \pm 0.05	6.60 Max.	1.27 \pm 0.05	3.05 \pm 0.05

Ordering Information

SDO 0402-4R7 M

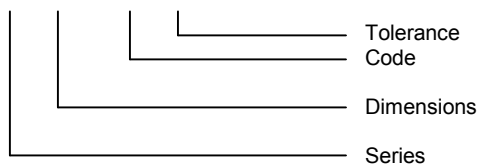

TYPE	SDO0402
QTY/REEL	2500pcs.

Characteristics

Part No.	L (μ H)	Test Frequency (KHz)	RDC Max.(Ω)	IDC Max.(A)
SDO0402-1R0M	1.0	100	0.05	2.90
SDO0402-1R5M	1.5	100	0.05	2.60
SDO0402-2R2M	2.2	100	0.07	2.30
SDO0402-3R3M	3.3	100	0.08	2.00
SDO0402-4R7M	4.7	100	0.09	1.50
SDO0402-6R8M	6.8	100	0.13	1.20
SDO0402-100M	10	100	0.16	1.10
SDO0402-150M	15	100	0.23	0.90
SDO0402-220M	22	100	0.37	0.70
SDO0402-330M	33	100	0.51	0.58
SDO0402-470M	47	100	0.64	0.50
SDO0402-680M	68	100	0.86	0.40
SDO0402-101M	100	100	1.27	0.31
SDO0402-151M	150	100	2.00	0.27
SDO0402-221M	220	100	3.11	0.22
SDO0402-331M	330	100	3.80	0.18
SDO0402-471M	470	100	5.50	0.16
SDO0402-681M	680	100	9.60	0.14
SDO0402-102M	1000	100	13.80	0.10

Tolerance: M = \pm 20%, M tolerance is standard.

SMD RF Inductor – SQH Series

SCHMID-M

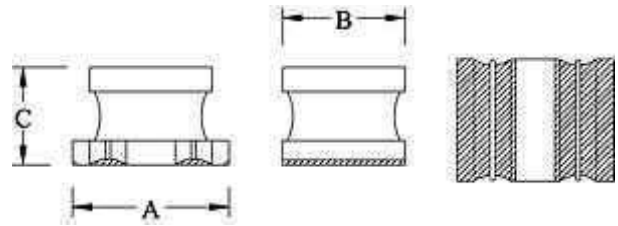

Features

- SQH Series inductors have a high quality factor at high frequency and low DC resistance
- The low DC resistance permits high current flow
- SQH has excellent solder heat resistance
- Both, flow and reflow soldering method can be used

Ordering Information

SQH 32 4R7 M

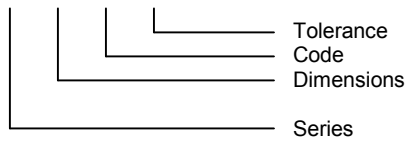

Dimensions

Part No.	A	B	C
SQH32	3.2 ± 0.30	2.5 ± 0.30	2.0 ± 0.20
SQH45	4.5 ± 0.30	3.2 ± 0.20	2.6 ± 0.20

Package

SIZE	SQH32	SQH45
QTY/REEL	1500pcs.	500pcs.

SMD RF Inductor – SQH Series



Code	L (μ H)	Test Frequency (Hz)	SQH32		SQH45	
			RDC Max. (Ω)	IDC Max. (mA)	RDC Max. (Ω)	IDC Max. (mA)
1R0	1.0	1M	0.50	445	0.20	500
1R2	1.2	1M	0.60	425	0.20	500
1R5	1.5	1M	0.60	400	0.30	500
1R8	1.8	1M	0.70	390	0.30	500
2R2	2.2	1M	0.80	370	0.30	500
2R7	2.7	1M	0.90	320	0.32	500
3R3	3.3	1M	1.00	300	0.35	500
3R9	3.9	1M	1.10	290	0.38	500
4R7	4.7	1M	1.20	270	0.40	500
5R6	5.6	1M	1.30	250	0.47	500
6R8	6.8	1M	1.50	240	0.50	450
8R2	8.2	1M	1.60	225	0.56	450
100	10	1M	1.80	190	0.56	400
120	12	1M	2.00	180	0.62	380
150	15	1M	2.20	170	0.73	360
180	18	1M	2.50	165	0.82	340
220	22	1M	2.80	150	0.94	320
270	27	1M	3.10	125	1.10	300
330	33	1M	3.50	115	1.20	270
390	39	1M	3.90	110	1.40	240
470	47	1M	4.30	100	1.50	220
560	56	1M	4.90	85	1.70	200
680	68	1M	5.50	80	1.90	180
820	82	1M	6.20	70	2.20	170
101	100	1M	7.00	80	2.50	160
121	120	1M	8.00	75	3.00	150
151	150	1M	9.30	70	3.70	130
181	180	1M	10.20	65	4.50	120
221	220	1M	11.80	65	5.40	110
271	270	1M	12.50	65	6.80	100
331	330	1M	13.00	65	8.20	95
391	390	1M	22.00	50	9.70	90
471	470	1K	25.00	45	11.80	80
561	560	1K	28.00	40	14.50	70
681	680	1K			17.00	65
821	820	1K			20.50	60
102	1000	1K			25.00	50
122	1200	1K			30.00	45
152	1500	1K			37.00	40
182	1800	1K			45.00	35
222	2200	1K			50.00	30

Tolerance: K = \pm 10%; M = \pm 20%

SMD Power Inductor – SSPK0402

SCHMID-M

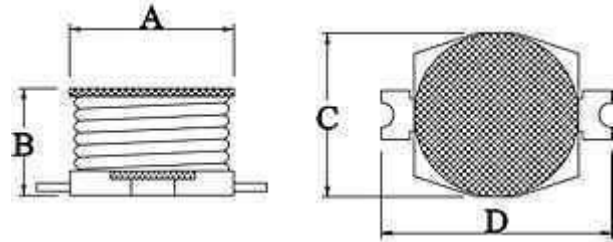
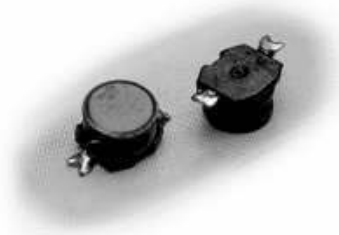

Features

- Designed for smallest possible size
- High energy storage and very low resistance
- Mighty temperature deflection prevents damage during solder reflow

Dimensions

Part No.	A	B	C	D
SSPK0402	4.4 ± 0.15	3.1 Max.	4.4 Max.	6.3 Max.
QTY/REEL	2000pcs.			

Ordering Information

SSPK 0402-4R7 M

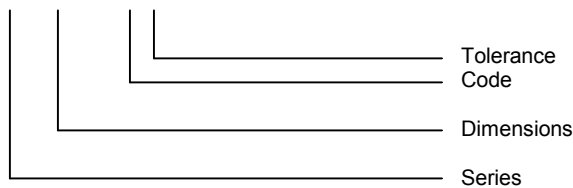

Characteristics

Tolerance: M = ± 20%, M tolerance is standard.

Part No.	L (µH)	Test Frequency (KHz)	RDC Max. (Ω)	IDC Max. (A)
SSPK0402-1R0M	1.0	100	0.072	1.34
SSPK0402-1R5M	1.5	100	0.084	1.22
SSPK0402-2R2M	2.2	100	0.108	1.08
SSPK0402-3R3M	3.3	100	0.134	0.97
SSPK0402-4R7M	4.7	100	0.160	0.91
SSPK0402-6R8M	6.8	100	0.197	0.79
SSPK0402-100M	10	100	0.330	0.63
SSPK0402-120M	12	100	0.350	0.59
SSPK0402-150M	15	100	0.400	0.56
SSPK0402-180M	18	100	0.450	0.51
SSPK0402-220M	22	100	0.534	0.47
SSPK0402-270M	27	100	0.618	0.43
SSPK0402-330M	33	100	0.903	0.37
SSPK0402-390M	39	100	1.010	0.34
SSPK0402-470M	47	100	1.355	0.29
SSPK0402-560M	56	100	1.515	0.28
SSPK0402-680M	68	100	1.713	0.26
SSPK0402-820M	82	100	2.312	0.22
SSPK0402-101M	100	100	2.640	0.21
SSPK0402-121M	120	100	3.502	0.19
SSPK0402-151M	150	100	4.132	0.17
SSPK0402-181M	180	100	4.534	0.16
SSPK0402-221M	220	100	6.646	0.13
SSPK0402-271M	270	100	7.523	0.12

SMD Power Inductor – SSPH Series

SCHMID-M

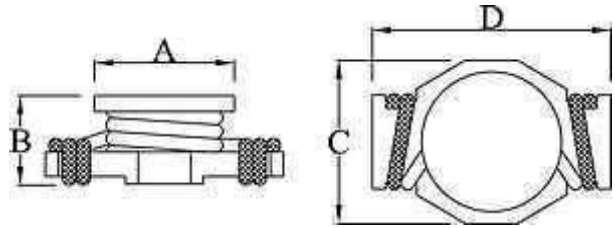

Features

- For high current, low voltage → DC/DC Converters
- Microprocessors
(esp. the latest generation of 3.3V products)
- High current rating, low DC resistance
- Reliable surface mounting with a large flat top and self-leaded design

Dimensions

Part No.	A	B	C	D
SSPH0504	4.8 ± 0.15	5.00 Max.	6.10 Max.	8.89 Max.
SSPH0804	8.6 Max.	6.35 Max.	9.91 Max.	13.21 Max.
SSPH1306	13.0 Max.	8.00 Max.	16.26 Max.	22.35 Max.

Ordering Information

SSPH 0504-4R7 M

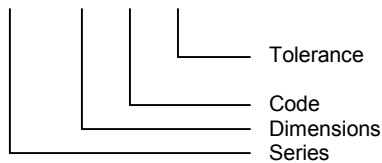

TYPE	SSPH0504	SSPH0804	SSPH1306
QTY/REEL	1000pcs.	750pcs.	250pcs.

Characteristics

Tolerance: M = ± 20%, M tolerance is standard.

Part No.	L (µH)	Test Frequency (KHz)	RDC Max.(Ω)	IDC Max.(A)
SSPH0504-R56M	0.56	100	0.010	7.70
SSPH0504-1R2M	1.20	100	0.017	5.30
SSPH0504-2R2M	2.20	100	0.035	3.50
SSPH0504-4R7M	4.70	100	0.054	2.60
SSPH0504-100M	10.0	100	0.111	1.90
SSPH0504-150M	15.0	100	0.170	1.50
SSPH0504-220M	22.0	100	0.250	1.20
SSPH0504-330M	33.0	100	0.350	0.99
SSPH0504-470M	47.0	100	0.470	0.87
SSPH0804-R33M	0.33	100	0.002	20.0
SSPH0804-R68M	0.68	100	0.005	13.0
SSPH0804-1R0M	1.00	100	0.006	11.0
SSPH0804-1R5M	1.50	100	0.008	9.00
SSPH0804-2R2M	2.20	100	0.011	7.80
SSPH0804-2R7M	2.70	100	0.012	7.00
SSPH0804-3R3M	3.30	100	0.014	6.40
SSPH0804-4R7M	4.70	100	0.018	5.40
SSPH1306-R78M	0.78	100	0.0026	30.0
SSPH1306-1R5M	1.50	100	0.004	25.0
SSPH1306-2R2M	2.20	100	0.0061	20.0
SSPH1306-3R3M	3.30	100	0.0086	17.0
SSPH1306-3R9M	3.90	100	0.010	15.0
SSPH1306-4R7M	4.70	100	0.014	13.0
SSPH1306-6R0M	6.00	100	0.017	12.0
SSPH1306-7R8M	7.80	100	0.018	11.0
SSPH1306-100M	10.0	100	0.026	10.0
SSPH1306-150M	15.0	100	0.032	8.00

SMD Power Inductor – SVLP Series

SCHMID-M

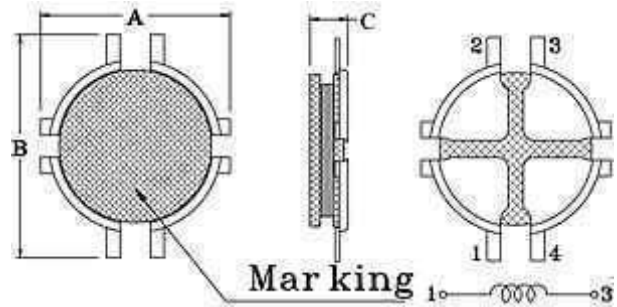

Features

- SMD Power Coil for power supplies
- Open magnetic path construction based on a low-height drum core
- Supports large current

Dimensions

Part No.	A	B	C
SVLP0515	5.4 ± 0.1	6.3 ± 0.2	1.5 Max.
QTY/REEL	4000pcs.		

Ordering Information

SVLP 0515 -4R7 M

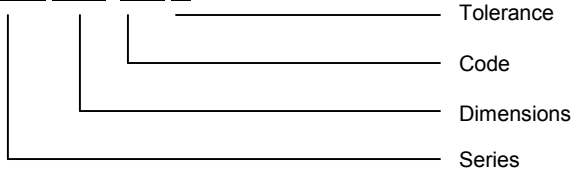

Characteristics

Tolerance: M = ± 20%, M tolerance is standard.

Part No.	L (µH)	Test Frequency (KHz)	RDC Max. (Ω)	IDC Max. (A)
SVLP0515-2R7M	2.7	100	0.17	1.26
SVLP0515-4R7M	4.7	100	0.24	1.08
SVLP0515-6R8M	6.8	100	0.30	0.90
SVLP0515-100M	10	100	0.45	0.72
SVLP0515-150M	15	100	0.71	0.63
SVLP0515-220M	22	100	0.96	0.50
SVLP0515-330M	33	100	1.47	0.41
SVLP0515-470M	47	100	1.93	0.36

SMD Power Inductor – SCMD Series

SCHMID-M

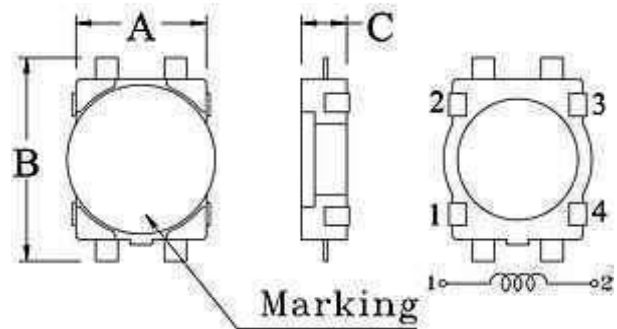

Features

- Thinnest power coil
- Ceramic cover provides best possible surface for pick and place handling
- Perfect for small cards

Dimensions

Part No.	A	B	C
SCMD0401	4.4 Max.	5.8 Max.	1.2 Max.
QTY/REEL	5000pcs.		

Ordering Information

SCMD 0401-4R7 M

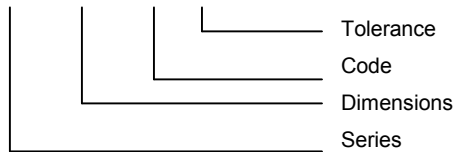

Characteristics

Tolerance: M = $\pm 20\%$, M tolerance is standard.

Part No.	L (μH)	Test Frequency (KHz)	RDC Max. (Ω)	IDC Max. (A)
SCMD0401-2R2M	2.2	100	0.116	0.95
SCMD0401-3R3M	3.3	100	0.174	0.77
SCMD0401-4R7M	4.7	100	0.216	0.75
SCMD0401-6R8M	6.8	100	0.296	0.62
SCMD0401-100M	10	100	0.457	0.50
SCMD0401-150M	15	100	0.676	0.40
SCMD0401-220M	22	100	1.066	0.30
SCMD0401-330M	33	100	1.647	0.24
SCMD0401-470M	47	100	2.843	0.18

SMD Shielded Power Inductor – SPRD Series

SCHMID-M

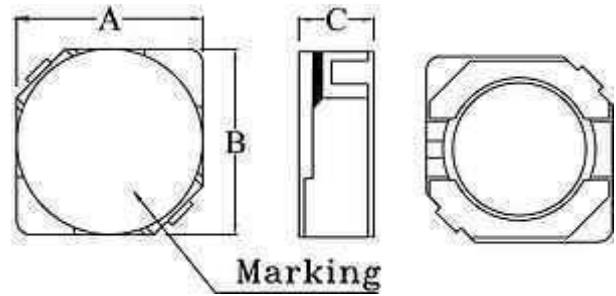

Features

- SPRD Series is superior to be high saturation for surface mounting
- Very thin and compact
- With large permissible DC current and low DC resistance
- Magnetic shielding surface mount inductor with high current rating

Ordering Information

SPRD 0315-4R7 M

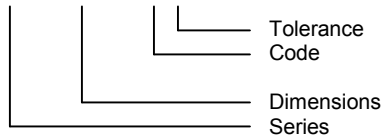

Dimensions

Part No.	A	B	C
SPRD0315	3.8 ± 0.2	3.8 ± 0.2	1.8 Max.
SPRD0402	4.7 ± 0.3	4.7 ± 0.3	2.0 Max.
SPRD0403	4.7 ± 0.3	4.7 ± 0.3	3.0 Max.
SPRD0503	5.7 ± 0.3	5.7 ± 0.3	3.0 Max.
SPRD0603	6.7 ± 0.3	6.7 ± 0.3	3.0 Max.
SPRD0604	6.7 ± 0.3	6.7 ± 0.3	4.0 Max.

Package

SIZE	SPRD0315	SPRD0402	SPRD0403	SPRD0503	SPRD0603	SPRD0604
QTY/REEL	2000pcs.	2000pcs.	2000pcs.	2000pcs.	1000pcs.	1000pcs.



Code	L (μ H)	SPRD0315		SPRD0402		SPRD0403		SPRD0503		SPRD0603		SPRD0604	
		RDC Max. (Ω)	IDC Max. (A)	RDC Max. (Ω)	IDC Max. (A)	RDC Max. (Ω)	IDC Max. (A)	RDC Max. (Ω)	IDC Max. (A)	RDC Max. (Ω)	IDC Max. (A)	RDC Max. (Ω)	IDC Max. (A)
1R0	1.0			0.045	1.72								
1R2	1.2					0.024	2.56						
1R8	1.8					0.028	2.20						
2R2	2.2			0.075	1.32	0.032	2.04						
2R5	2.5							0.018	2.60				
2R7	2.7			0.105	1.28	0.044	1.60						
3R0	3.0							0.024	2.40	0.024	3.00		
3R3	3.3	0.066	0.80	0.110	1.04	0.050	1.57					0.020	3.50
3R9	3.9	0.081	0.75	0.155	0.88	0.065	1.44			0.027	2.60		
4R2	4.2							0.031	2.20				
4R7	4.7	0.091	0.68	0.162	0.84	0.072	1.32						
5R0	5.0									0.031	2.40	0.024	2.90
5R3	5.3							0.038	1.90				
5R6	5.6	0.102	0.62	0.170	0.80	0.101	1.17						
6R0	6.0									0.035	2.25		
6R2	6.2							0.045	1.80			0.027	2.50
6R8	6.8	0.130	0.58	0.200	0.76	0.109	1.12						
7R3	7.3									0.054	2.10		
7R4	7.4											0.031	2.30
8R2	8.2	0.140	0.51	0.245	0.68	0.118	1.04	0.053	1.60				
8R6	8.6									0.058	1.85		
8R7	8.7											0.034	2.20
100	10	0.190	0.46	0.200	0.61	0.129	1.00	0.065	1.30	0.065	1.70	0.038	2.00
120	12	0.205	0.42	0.210	0.56	0.132	0.84	0.076	1.20	0.070	1.55	0.053	1.70
150	15	0.272	0.38	0.240	0.50	0.149	0.76	0.103	1.10	0.084	1.40	0.057	1.60
180	18	0.327	0.34	0.338	0.48	0.166	0.72	0.110	1.00	0.095	1.32	0.092	1.50
220	22	0.356	0.31	0.397	0.41	0.235	0.70	0.122	0.90	0.128	1.20	0.096	1.30
270	27	0.470	0.28	0.441	0.35	0.261	0.58	0.175	0.85	0.142	1.05	0.109	1.20
330	33	0.560	0.26	0.694	0.32	0.378	0.56	0.189	0.75	0.165	0.97	0.124	1.10
390	39	0.700	0.24	0.709	0.30	0.384	0.50	0.212	0.70	0.210	0.86	0.138	1.00
470	47	0.775	0.21			0.587	0.48	0.260	0.62	0.238	0.80	0.155	0.95
560	56					0.625	0.41	0.305	0.58	0.277	0.73	0.202	0.85
680	68					0.699	0.35	0.355	0.52	0.304	0.65	0.234	0.75
820	82							0.915	0.32	0.463	0.46	0.390	0.60
101	100	4,5	0,105					1.020	0.29	0.520	0.42	0.535	0.54
121	120							1.270	0.27				
151	150							1.350	0.24				
181	180							1.540	0.22				

Tolerance: M = $\pm 20\%$, M tolerance is standard.

SMD Shielded Power Inductor- SPRD02 series

SCHMID-M

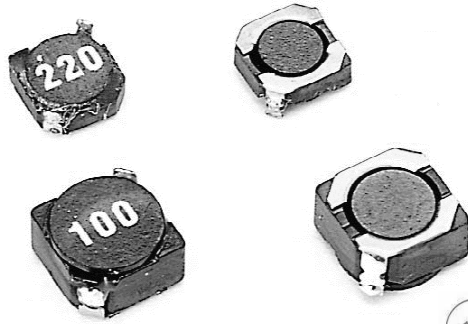

Dimensions and PCB Pattern

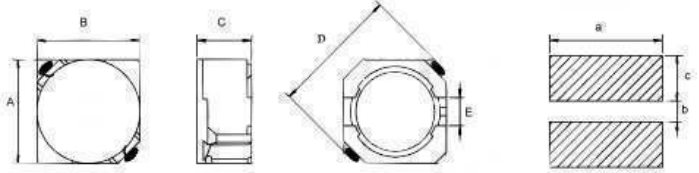

Features

- Very thin and compact with shielding
- Large permissible DC current
- Low DC resistance
- Operating temperature -25° to $+85^{\circ}\text{C}$
- Applications DC / DC converter, LCD TV, small size communication equipment

	A	B	C	D	E	a	b	c
SPRD0208	3,2 max.	3,2 max.	0,9 max.	3,3 typ.	0,9 typ.	3,6	0,8	1,3
SPRD0214	3,2 max.	3,2 max.	1,6 max.	3,3 typ.	0,9 typ.	3,6	0,8	1,3
SPRD0218	3,2 max.	3,2 max.	2,0 max.	3,3 typ.	0,9 typ.	3,6	0,8	1,3

SPRD0208	Inductance(μH)	Test Frequency(V/hz)	DC Resistance(mOhm)	Saturation Current (mA)
SPRD0208-1R5M	1,5	1,0/100K	163	1000
SPRD0208-2R2M	2,2	1,0/100K	238	900
SPRD0208-3R3M	3,3	1,0/100K	313	750
SPRD0208-4R7M	4,7	1,0/100K	475	600
SPRD0208-6R8M	6,8	1,0/100K	600	500
SPRD0208-100M	10,0	1,0/100K	938	400
SPRD0208-150M	15,0	1,0/100K	1625	300
SPRD0208-220M	22,0	1,0/100K	2125	250

SPRD0214	Inductance(μH)	Test Frequency(V/hz)	DC Resistance(mOhm)	Saturation Current (mA)
SPRD0214-2R2M	2,2	1,0/100K	113	1700
SPRD0214-3R3M	3,3	1,0/100K	156	1300
SPRD0214-4R7M	4,7	1,0/100K	225	1000
SPRD0214-6R8M	6,8	1,0/100K	325	900
SPRD0214-100M	10,0	1,0/100K	475	700
SPRD0214-220M	22,0	1,0/100K	875	400
SPRD0214-330M	33,0	1,0/100K	1625	400

SPRD0218	Inductance(μH)	Test Frequency(V/hz)	DC Resistance(mOhm)	Saturation Current (mA)
SPRD0218-1R7M	1,7	1,0/100K	63	2000
SPRD0218-2R2M	2,2	1,0/100K	75	1800
SPRD0218-3R3M	3,3	1,0/100K	100	1400
SPRD0218-4R7M	4,7	1,0/100K	156	1200
SPRD0218-5R6M	5,6	1,0/100K	188	1150
SPRD0218-6R3M	6,3	1,0/100K	225	1100
SPRD0218-6R8M	6,8	1,0/100K	231	1000
SPRD0218-8R2M	8,2	1,0/100K	238	800
SPRD0218-100M	10,0	1,0/100K	275	700
SPRD0218-150M	15,0	1,0/100K	475	600
SPRD0218-220M	22,0	1,0/100K	750	500
SPRD0218-330M	33,0	1,0/100K	938	400
SPRD0218-470M	47,0	1,0/100K	2000	300

SMD Shielded Power Inductor – SPRD1004

SCHMID-M

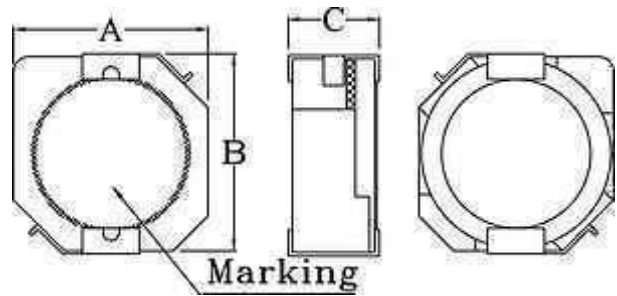
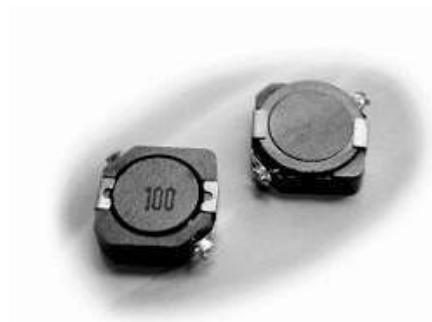

Features

- Inductance is from 10 μ H to 330 μ H
- Designed for smallest possible size
- High energy storage and very low resistance
- Mighty temperature deflection prevents damage during solder flow

Dimensions

Part No.	A	B	C
SPRD1004	10.0 \pm 0.3	10.1 \pm 0.3	3.8 \pm 0.2
QTY/REEL	500pcs.		

Ordering Information

SPRD 1004 – 330 M

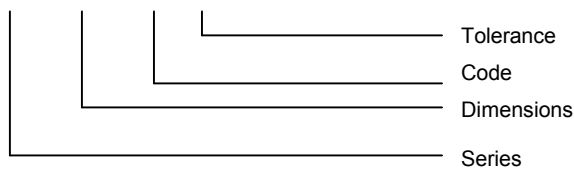

Characteristics

Tolerance: M = \pm 20%, M tolerance is standard.

Part No.	Inductance (μ H)	Test Frequency (KHz)	RDC Max. (Ω)	IDC Max. (A)
SPRD1004-100M	10	100	0.035	4.40
SPRD1004-150M	15	100	0.050	3.60
SPRD1004-220M	22	100	0.073	2.90
SPRD1004-330M	33	100	0.093	2.30
SPRD1004-470M	47	100	0.128	2.10
SPRD1004-680M	68	100	0.213	1.50
SPRD1004-101M	100	100	0.304	1.35
SPRD1004-151M	150	100	0.506	1.15
SPRD1004-221M	220	100	0.756	0.92
SPRD1004-331M	330	100	1.090	0.7

SMD Shielded Power Inductor – SPRH Series

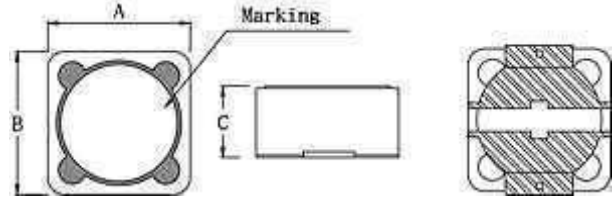

Features

- SPRH series is superior to be high saturation for surface mounting
- Magnetic shielding
- Very small footprint
- Flat-top for pick and place
- Increased size selection-guide
- Low resistance to keep power loss minimum

Dimensions

Part No.	A	B	C
SPRH0703	7.3 ± 0.2	7.3 ± 0.2	3.2 ± 0.2
SPRH0704	7.3 ± 0.2	7.3 ± 0.2	4.5 Max.
SPRH1205	12.0 ± 0.3	12.0 ± 0.3	6.0 Max.
SPRH1207	12.0 ± 0.3	12.0 ± 0.3	8.0 Max.
SPRH1209	12.0 ± 0.3	12.0 ± 0.3	10.0 Max.

Ordering Information

SPRH 0703 – 5R8 M

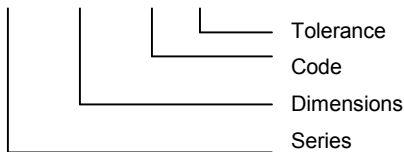

SIZE	SPRH0703	SPRH0704	SPRH1205	SPRH1207	SPRH1209
QTY/REEL	1000pcs.	1000pcs.	500pcs.	500pcs.	500pcs.

Characteristics

Tolerance: M = ± 20%, M tolerance is standard.

Code	L (µH)	SPRH0703		SPRH0704		SPRH1205		SPRH1207		SPRH1209	
		RDC Max.(Ω)	IDC Max.(A)	RDC Max.(Ω)	IDC Max.(A)	RDC Max.(Ω)	IDC Max.(A)	RDC Max.(Ω)	IDC Max.(A)	RDC Max.(Ω)	IDC Max.(A)
1R0	1.0							0.007	14.00	0.030	20.00
1R3	1.3					0.012	8.00				
2R1	2.1					0.014	7.00				
2R4	2.4							0.011	10.30	0.062	15.00
3R1	3.1					0.017	6.00				
3R5	3.5							0.013	9.30		
4R4	4.4					0.020	5.00				
4R6	4.6							0.014	9.10		
5R8	5.8					0.021	4.40	0.017	8.60		
7R4	7.4							0.018	7.40		
7R5	7.5					0.024	4.20				
100	10	0.072	1.68	0.049	1.84	0.025	4.00	0.020	6.70	0.020	8.50
120	12	0.098	1.52	0.058	1.71	0.027	3.50	0.022	6.45		
150	15	0.130	1.33	0.081	1.47	0.030	3.30	0.027	5.65	0.022	6.00
180	18	0.140	1.20	0.091	1.31	0.034	3.00	0.028	5.10		
220	22	0.190	1.07	0.110	1.23	0.036	2.80	0.037	4.70	0.039	5.00
270	27	0.210	0.96	0.150	1.12	0.051	2.30	0.042	4.20		
330	33	0.240	0.91	0.170	0.96	0.057	2.10	0.054	3.90	0.052	4.30
390	39	0.320	0.77	0.230	0.91	0.068	2.00	0.061	3.50		
470	47	0.360	0.76	0.260	0.88	0.075	1.80	0.078	3.25	0.061	4.20
560	56	0.470	0.68	0.350	0.75	0.110	1.70	0.090	2.90		
680	68	0.520	0.61	0.380	0.69	0.120	1.50	0.120	2.60	0.085	3.00
820	82	0.690	0.57	0.430	0.61	0.140	1.40	0.119	2.40		
101	100	0.790	0.50	0.610	0.60	0.160	1.30	0.151	2.10	0.160	2.40
121	120	0.890	0.49	0.660	0.52	0.170	1.10	0.169	1.90		
151	150	1.270	0.43	0.880	0.46	0.230	1.00	0.227	1.80	0.190	2.20
181	180	1.450	0.39	0.980	0.42	0.290	0.90	0.299	1.55	0.290	2.00
221	220	1.650	0.35	1.170	0.36	0.400	0.80	0.338	1.45	0.290	1.60
271	270	2.310	0.32	1.640	0.34	0.460	0.75	0.419	1.30		
331	330	2.620	0.28	1.860	0.32	0.510	0.68	0.471	1.20	0.386	1.30
391	390	2.940	0.26	2.850	0.29	0.690	0.65	0.572	1.10		
471	470	4.180	0.24	3.010	0.26	0.770	0.58	0.741	1.00	0.490	1.00
561	560	4.670	0.22	3.620	0.23	0.860	0.54	0.852	0.95		
681	680	5.730	0.19	4.630	0.22	1.200	0.48	1.130	0.85	0.720	0.92
821	820	6.540	0.18	5.200	0.20	1.340	0.43	1.240	0.75		
102	1000	9.440	0.16	6.000	0.18	1.530	0.40	1.500	0.70	0.900	0.78

SMD Shielded Power Transformers- SPRH-DD series

SCHMID-M

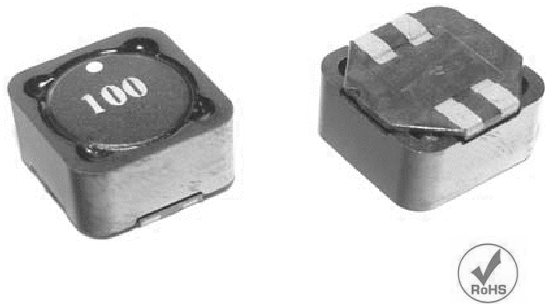

Dimensions and PCB Pattern

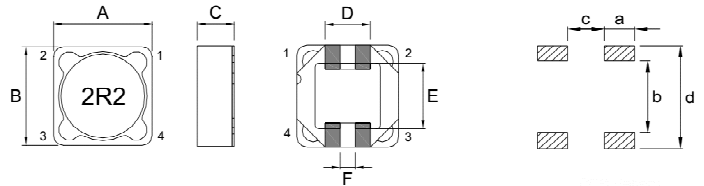

Features

- Two identical windings with shielding
- Windings 1 - 3 : 2 - 4
- Low DC resistance and high energy storage
- Operating temperature -25° to $+85^{\circ}\text{C}$
- Applications DC / DC converter, LCD TV, Power supply for VCR, DC/AC inverter

	A	B	C	D	E	F	a	b	c	d
SPRH1204_DD	12,5 max.	12,5 max.	5,0 max.	5,2 max.	7,8 max.	1,0 typ.	2,5	7,0	0,6	12,8
SPRH1205_DD	12,5 max.	12,5 max.	6,0 max.	5,2 max.	7,8 max.	1,0 typ.	2,5	7,0	0,6	12,8
SPRH1207_DD	12,5 max.	12,5 max.	8,0 max.	5,2 max.	7,8 max.	1,0 typ.	2,5	7,0	0,6	12,8

SPRH1207-DD	Inductance(μH)	Test Frequency(V/hz)	DC Resistance(mOhm)	Saturation Current (mA)
SPRH1207-1R5M-DD	1,5	1,0/100K	11,0	10000
SPRH1207-2R2M-DD	2,2	1,0/100K	12,0	8100
SPRH1207-3R3M-DD	3,3	1,0/100K	13,5	7500
SPRH1207-4R7M-DD	4,7	1,0/100K	15,8	7000
SPRH1207-6R1M-DD	6,1	1,0/100K	19,0	6900
SPRH1207-7R6M-DD	7,6	1,0/100K	23,0	6200
SPRH1207-100M-DD	10	1,0/100K	24,0	6000
SPRH1207-120M-DD	12	1,0/100K	26,0	5300
SPRH1207-150M-DD	15	1,0/100K	33,0	5000
SPRH1207-180M-DD	18	1,0/100K	40,0	4000
SPRH1207-220M-DD	22	1,0/100K	46,0	3800
SPRH1207-270M-DD	27	1,0/100K	56,0	3600
SPRH1207-330M-DD	33	1,0/100K	64,8	3000
SPRH1207-390M-DD	39	1,0/100K	72,9	2750
SPRH1207-470M-DD	47	1,0/100K	75,0	2500
SPRH1207-560M-DD	56	1,0/100K	95,0	2350
SPRH1207-680M-DD	68	1,0/100K	104	2100
SPRH1207-820M-DD	82	1,0/100K	160	1950
SPRH1207-101M-DD	100	1,0/100K	220	1700
SPRH1207-121M-DD	120	1,0/100K	250	1600
SPRH1207-151M-DD	150	1,0/100K	280	1420
SPRH1207-181M-DD	180	1,0/100K	350	1300
SPRH1207-221M-DD	220	1,0/100K	390	1160
SPRH1207-271M-DD	270	1,0/100K	560	1060
SPRH1207-331M-DD	330	1,0/100K	640	950
SPRH1207-391M-DD	390	1,0/100K	700	880
SPRH1207-471M-DD	470	1,0/100K	980	790
SPRH1207-561M-DD	560	1,0/100K	1070	730
SPRH1207-681M-DD	680	1,0/100K	1460	670
SPRH1207-821M-DD	820	1,0/100K	1640	600
SPRH1207-102M-DD	1000	1,0/100K	1820	550

SMD Shielded Power Inductor – SSPS Series

SCHMID-M

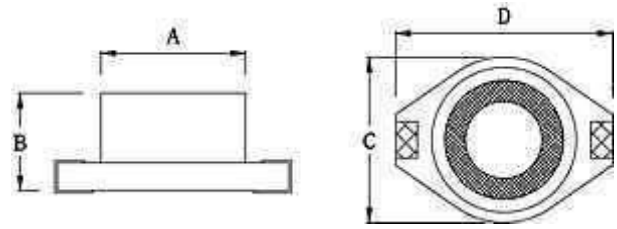

Features

- Magnetic shielding
- Flat bottom surface ensures secure and reliable mounting
- Low DC resistance, low profile and high current rating capacities

Dimensions

Part No.	A	B	C	D
SSPS0804	8.40 ± 0.20	5.08 Max.	9.40 Max.	12.95 Max.
SSPS1306	12.70 ± 0.20	7.62 Max.	15.24 Max.	18.54 Max.

Ordering Information

SSPS 0804-100 M

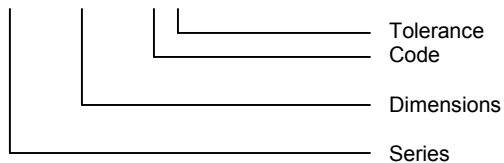

SSPS0804	SSPS1306
1000pcs.	250pcs.

Characteristics

Tolerance: M = ± 20%, M tolerance is standard.

Code	L (µH)	SSPS0804		SSPS1306	
		RDC Max. (Ω)	IDC Max. (A)	RDC Max. (Ω)	IDC Max. (A)
1R0	1.0	0.021	5.60		
1R5	1.5	0.022	5.20		
2R2	2.2	0.032	5.00		
3R3	3.3	0.039	3.90		
4R7	4.7	0.054	3.20		
6R8	6.8	0.075	2.80		
100	10	0.101	2.40	0.040	8.00
150	15	0.150	2.00	0.048	7.00
220	22	0.207	1.60	0.059	6.00
330	33	0.334	1.40	0.075	5.00
470	47	0.472	1.00	0.097	4.00
680	68			0.138	3.00
101	100			0.207	2.40
151	150			0.293	2.10
221	220			0.470	1.90
331	330			0.780	1.10
471	470			1.080	1.10
681	680			1.400	0.96
102	1000			2.010	0.80

Test Frequency 100KHz

SMD Shielded Power Inductor – SSPS0403 Series

SCHMID-M

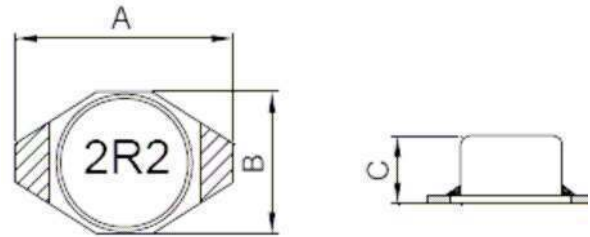

Features

- Magnetic shielding
- Flat bottom surface ensures secure and reliable mounting
- Low DC resistance, low profile very effective in space-conscious applications and high current rating capacities

Dimensions

Part No.	A	B	C
SSPS0403	6,60 max.	4.45 max.	2.92 max.

Ordering Information

SSPS 0403–100 M

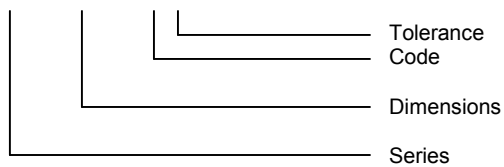

Characteristics

Tolerance: M = ± 20%, M tolerance is standard.

Code	Inductance (µH)	RDC max. (mΩ)	Test frequency (Volt/Hz)	IDC max. (mA)
1R0	1.0	40	0.1/100k	3000
1R5	1.5	45	0.1/100k	2300
2R2	2.2	50	0.1/100k	1800
3R3	3.3	55	0.1/100k	1600
4R7	4.7	60	0.1/100k	1400
6R8	6.8	65	0.1/100k	1200
100	10	75	0.1/100k	1000
150	15	90	0.1/100k	800
220	22	110	0.1/100k	700
330	33	190	0.1/100k	600
470	47	230	0.1/100k	500
680	68	290	0.1/100k	400
101	100	480	0.1/100k	300
151	150	590	0.1/100k	260
221	220	770	0.1/100k	220
331	330	1400	0.1/100k	200
471	470	1800	0.1/100k	190
681	680	2200	0.1/100k	160
102	1000	3400	0.1/100k	150
152	1500	4200	0.1/100k	120
222	2200	8500	0.1/100k	100
332	3300	11000	0.1/100k	80
472	4700	13900	0.1/100k	60
682	6800	25000	0.1/100k	40
103	10000	32800	0.1/100k	20

SMD Shielded Power Inductor – SSB Series

SCHMID-M

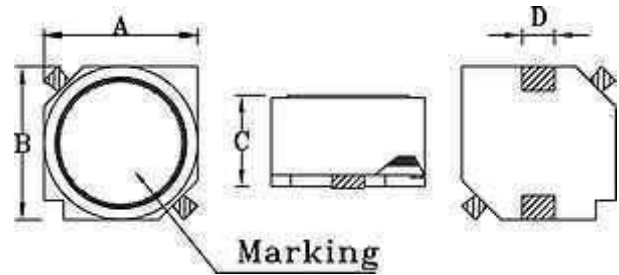

Features

- Magnetic shielding
- Flat bottom surface ensures secure and reliable mounting
- Low DC resistance, low profile and high current rating capacities

Ordering Information

SSB 0703-4R7 M

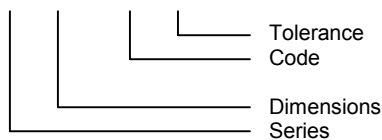

Dimensions

Part No.	A	B	C
SSB0703	7.6 Max.	7.6 Max.	3.5 Max.
SSB0705	7.6 Max.	7.6 Max.	5.1 Max.
SSB1003	10.5 Max.	10.5 Max.	3.5 Max.
SSB1206	12.5 ± 0.3	12.5 ± 0.3	5.5 ± 0.35
SSB1207	12.5 ± 0.3	12.5 ± 0.3	6.5 ± 0.35

SIZE	SSB0703	SSB0705	SSB1003	SSB1206	SSB1207
QTY/REEL	1000pcs.	1000pcs.	1000pcs.	500pcs.	500pcs.

Characteristics

Tolerance: M = ± 20%, M tolerance is standard.

Code	L (µH)	SSB0703		SSB0705		SSB1003		SSB1206		SSB1207	
		RDC Max.(Ω)	IDC Max.(A)	RDC Max.(Ω)	IDC Max.(A)	RDC Max.(Ω)	IDC Max.(A)	RDC Max.(Ω)	IDC Max.(A)	RDC Max.(Ω)	IDC Max.(A)
1R0	1.0	0.019	3.12	0.020	2.80						
1R5	1.5	0.023	2.85	0.024	2.59						
2R0	2.0									0.014	6.20
2R2	2.2	0.028	2.66	0.028	2.38	0.016	5.00				
3R3	3.3	0.035	2.26	0.034	2.14						
4R0	4.0					0.023	3.20				
4R2	4.2									0.018	5.50
4R7	4.7	0.043	1.96	0.039	1.96						
6R0	6.0							0.020	4.90		
6R8	6.8	0.055	1.76	0.050	1.79						
7R0	7.0					0.042	2.30			0.022	5.00
100	10	0.080	1.34	0.055	1.63	0.058	2.10	0.026	4.30	0.025	4.80
120	12	0.090	1.23	0.073	1.42						
150	15	0.120	1.09	0.081	1.33	0.080	1.60	0.032	3.90	0.029	4.40
180	18	0.130	0.99	0.102	1.15						
220	22	0.150	0.90	0.115	1.09	0.109	1.30	0.041	3.40	0.038	3.80
270	27	0.210	0.81	0.159	0.91						
330	33	0.250	0.72	0.182	0.84	0.177	1.10	0.050	3.10	0.049	3.40
390	39	0.310	0.67	0.199	0.80						
470	47	0.350	0.60	0.221	0.75	0.234	1.00	0.075	2.50	0.070	2.80
560	56	0.430	0.55	0.306	0.64						
680	68	0.520	0.50	0.345	0.60	0.324	0.90	0.101	2.20	0.095	2.40
820	82	0.600	0.46	0.390	0.57						
101	100	0.792	0.41	0.432	0.50	0.519	0.72	0.141	1.80	0.148	1.90
121	120			0.440	0.47						
151	150			0.730	0.40			0.228	1.40		
181	180			0.780	0.39						
221	220			0.940	0.33	1.215	0.46	0.624	1.20	0.328	1.20
271	270			1.250	0.31						
331	330			1.400	0.27			0.492	1.00		
471	470			1.700	0.25			0.624	0.88		
561	560			2.390	0.22						
681	680							0.912	0.73		
102	1000							1.344	0.60		
152	1500							2.076	0.48		

SMD common mode choke wire wound type - SPWC serie

SCHMID-M

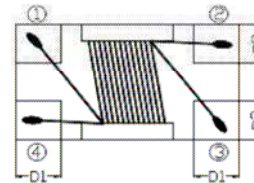
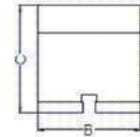
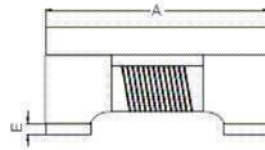

Features

- SMD wire wound common mode choke with epoxy coating (SPWC 0805) or magnetic shield (SPWC 1206)
- Lower DC resistance, higher current tolerance and much stable performance
- Excellent Solderability and resistance to soldering heat
- High reliability and easy surface mount assembly

Ordering Information

SPWC - 0805 - 900

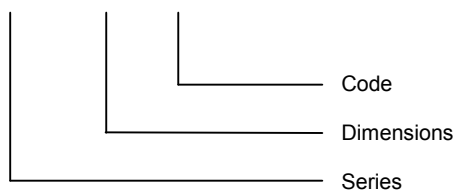

Part No.	A mm	B mm	C mm	D1 mm	D2 mm
SPWC0805	2.0 ± 0.10	1.2 ± 0.10	1.0 ± 0.10	0.45	0.40
SPWC1206	3.2 ± 0.10	1.6 ± 0.10	1.9 ± 0.10	0.60	0.60

Characteristics

Part Number	Impedance at 100MHz (Ω)	Rated Current (mA)	RDC (Ω) (Max)	RATED VOLTAGE (Vdc)
SPWC0805-670	67±25%	330	0,35	50
SPWC0805-900	90±25%	300	0,40	50
SPWC0805-121	120±25%	280	0,45	50
SPWC0805-181	180±25%	250	0,50	50

SPWC1206-900	90±25%	370	0,30	50
SPWC1206-161	160±25%	340	0,40	50
SPWC1206-261	260±25%	310	0,50	50
SPWC1206-601	600±25%	260	0,80	50
SPWC1206-102	1000±25%	230	1,00	50
SPWC1206-222	2200±25%	200	1,20	50

Operating temperature range -40°C to +125°C
Electrical specifications at 25°C
Packing reel, 2000pcs

SMD dual common mode choke SM6560

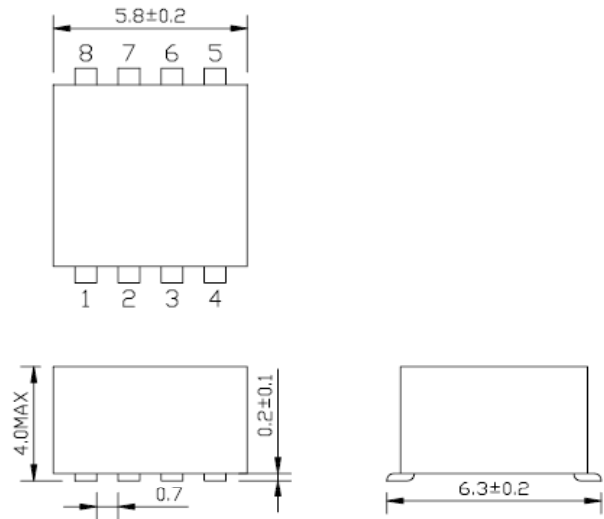
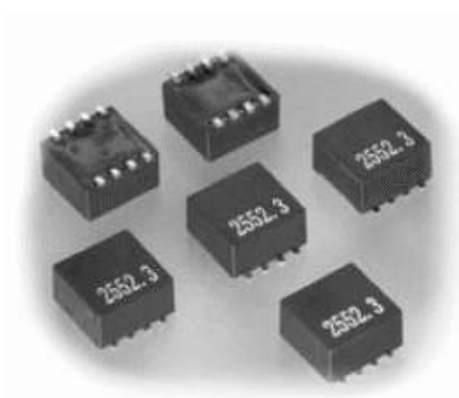

Features

- SMD Dual common mode choke coils
- Low profile and small size SMD
- Excellent Solderability and resistance to soldering heat
- High reliability and easy surface mount assembly

Ordering Information

SM - 6560 - 700

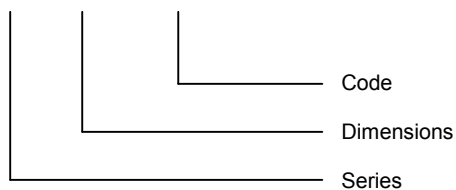

Characteristics

Part number	Impedance at 100MHz (Ω)	Impedance at 300MHz (Ω)	Rated current (mA)	DCR (mΩ) (Max)	Rated voltage (Vdc)	Isulation resistance (Ω)min
SM6560-700	70±25%	100 (Typ.)	500	30	100	100M
SM6560-161	160±25%	220 (Typ.)	500	45	100	100M
SM6560-291	290±25%	400 (Typ.)	500	60	100	100M
SM6560-451	450±25%	600 (Typ.)	500	70	100	100M

Impedance tolerance ± 25%
 Operating temperature range -40°C to +85°C
 Electrical specifications at 25°C
 Packing 13" reel, 1000pcs



Common Mode Filters - SMD - SID series

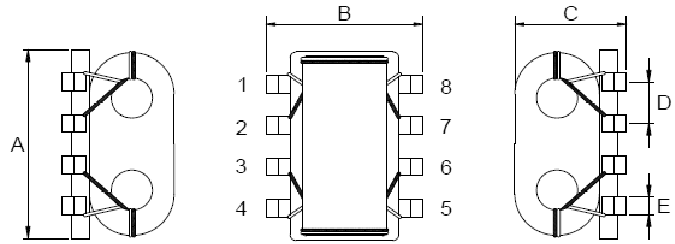
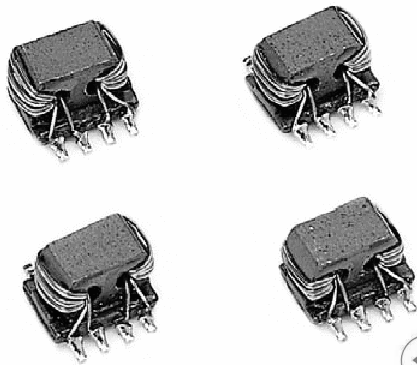

Series Name	A	B	C	D	E
SID335	5,9 ± 0,5	6,5 ± 0,5	4,1 ± 0,5	1,27 typ.	0,5 typ.

Features

- It has high common mode impedance in small size.
- It is effective for common mode noise suppression in digital equipment which radiation is caused from cables.
- Suitable for reflow soldering.

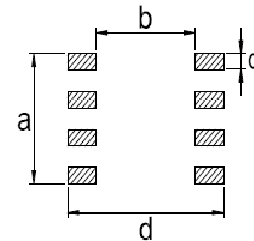

Application

- It is effective in high frequency noise suppression and suitable for suppression of radiation noise in signal cables. The dual winding type common mode choke coil structure enables noise suppression without degrading the signal.

Series Name	a	b	c	d
SID335	6,20	3,80	0,70	6,80

Standard parts

	Insulation Resistance (Ω)min.	Common mode Impedance (Ω)		DC resistance Max. (mΩ)	Rated Current max. (mA)
		At 100MHz	At 300Mhz		
SID335-1.5T_	100M	90 min	140 typ.	60	500
SID335-2.5T_	100M	200 min	450 typ.	65	500
SID335-3.5T_	100M	450 min	600 typ.	80	500

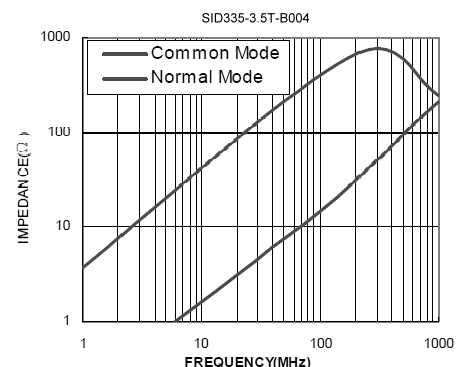
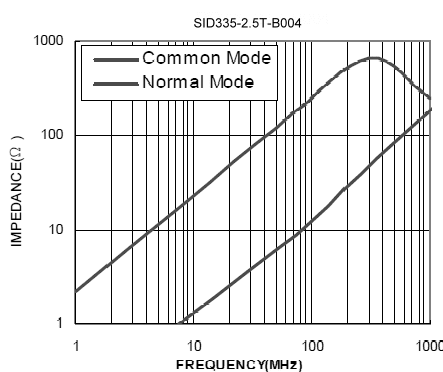
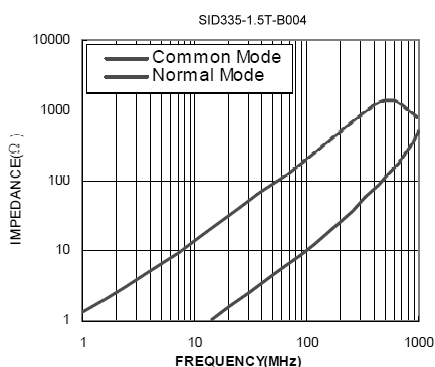

SMD Shielded Power Inductor- SSRP series

SCHMID-M

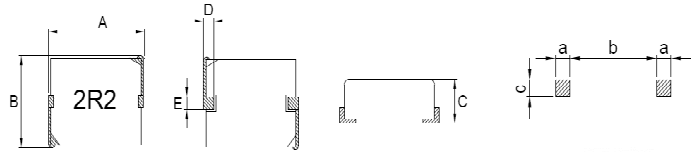

Series	A	B	C	D	E	a	b	c
SSRP0603	7,8 max.	7,0 max.	3,2max.	1,6±0,5	2,1±0,5	2,5	3,7	3,5
SSRP1203	13,9 max	13,5 max	3,7max.	2,5±0,5	3,0±0,5	4,0	7,0	4,5

Features

- Lowest DCR/Uh, in this package size
- Lowest height (3,0mm max.) in this package footprint
- Ultra low buzz noise, due to composite construction
- Frequency up to 5MHz

Application

- Thin type on-board power supply module for exchanger
- Laptop and notebook computers
- DC/DC converter in distributed power systems or VRM applications

Standard parts

	Inductance (uH)	Test frequency (Volt / Hz)	DC Resistance max. (mOhm)	Temperature Rise Current max. (A)	Saturation Current max. (A)
SSRP0603-R10_	0,10	1,0 / 100K	1,7	32,5	42,0
SSRP0603-R15_	0,15	1,0 / 100K	2,5	26,0	38,0
SSRP0603-R20_	0,20	1,0 / 100K	3,0	24,0	36,0
SSRP0603-R22_	0,22	1,0 / 100K	2,8	23,0	35,0
SSRP0603-R33_	0,33	1,0 / 100K	3,9	20,0	30,0
SSRP0603-R47_	0,47	1,0 / 100K	4,2	17,5	26,0
SSRP0603-R68_	0,68	1,0 / 100K	5,5	15,5	23,0
SSRP0603-R82_	0,82	1,0 / 100K	8,0	13,0	20,0
SSRP0603-1R0_	1,00	1,0 / 100K	10,0	11,0	16,0
SSRP0603-1R5_	1,50	1,0 / 100K	15,0	9,0	14,0
SSRP0603-2R2_	2,20	1,0 / 100K	20,0	8,0	12,0
SSRP0603-3R3_	3,30	1,0 / 100K	30,0	6,0	10,0
SSRP0603-4R7_	4,70	1,0 / 100K	40,0	5,5	6,5
SSRP0603-6R8_	6,80	1,0 / 100K	60,0	4,5	6,0
SSRP0603-8R2_	8,20	1,0 / 100K	68,0	4,0	5,5
SSRP0603-100_	10,00	1,0 / 100K	105,0	3,0	4,5
SSRP1203-R10_	0,10	1,0 / 100K	0,96	43,0	56,0
SSRP1203-R15_	0,15	1,0 / 100K	1,20	41,0	50,0
SSRP1203-R22_	0,22	1,0 / 100K	1,30	38,5	48,0
SSRP1203-R33_	0,33	1,0 / 100K	1,50	36,5	45,5
SSRP1203-R47_	0,47	1,0 / 100K	2,00	32,0	44,0
SSRP1203-R60_	0,60	1,0 / 100K	2,50	29,0	42,0
SSRP1203-R68_	0,68	1,0 / 100K	2,60	28,0	40,0
SSRP1203-R82_	0,82	1,0 / 100K	3,00	25,0	38,0
SSRP1203-1R0_	1,00	1,0 / 100K	3,50	24,0	36,0
SSRP1203-1R5_	1,50	1,0 / 100K	5,50	19,0	28,0
SSRP1203-1R8_	1,80	1,0 / 100K	7,00	16,5	24,0
SSRP1203-2R2_	2,20	1,0 / 100K	8,00	16,0	20,0
SSRP1203-3R3_	3,30	1,0 / 100K	12,00	12,0	18,0
SSRP1203-4R7_	4,70	1,0 / 100K	15,00	10,0	16,0
SSRP1203-5R6_	5,60	1,0 / 100K	18,00	9,5	14,0
SSRP1203-6R8_	6,80	1,0 / 100K	22,00	9,0	13,0

Tolerance: M = ± 20%, M tolerance is standard.

SMD Shielded Power Inductor – SSIH Series

SCHMID-M

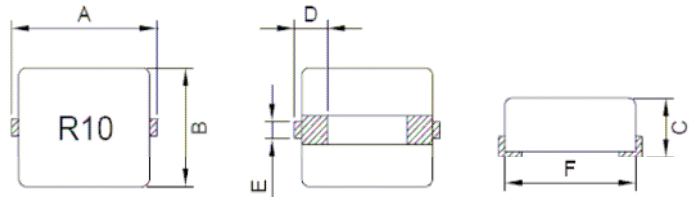

Features

- Lowest height (5.0mm/max) in this package footprint.
- Lowest DCR/ μH , in this package size.
- Low buzz noise, due to composite construction.
- Frequency up to 5MHz.
- Application : Laptop and notebook computers, thin type on-board power supply module for exchanger, DC/DC converter in distributed power systems or VRM applications.

Dimensions

Series name dim: mm	A	B	C	D	E	F
SSIH0605	7.2 max.	6.8 max.	5.0 max.	1.5 ± 0.5	2.5 ± 0.5	5.7 ± 0.5
SSIH1005	10.2 max.	6.8 max.	5.0 max.	1.5 ± 0.5	2.5 ± 0.5	8.7 ± 0.5
SSIH1208	13.5 max.	12.95 max.	8.0 max.	2.54 ± 0.5	5.0 ± 0.5	10.9 ± 0.5

Ordering Information

SSIH 0605-R10 M

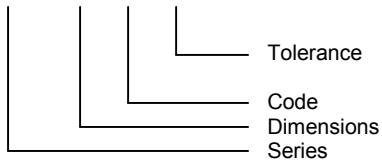

Characteristics

Tolerance: M = $\pm 20\%$, M tolerance is standard.

Part No.	L (μH)	Test Frequency (Volt / Hz)	RDC Max.(m Ω)	Temperature Rise Current max. (A)	Saturation Current max.(A)
SSIH0605-R10	0,10	0,25 / 1,0M	0,50	30	37
SSIH0605-R15	0,15	0,25 / 1,0M	0,50	24	30
SSIH0605-R20	0,20	0,25 / 1,0M	0,50	19	24
SSIH1005-R10	0,10	0,25 / 1,0M	0,65	40	50
SSIH1005-R15	0,15	0,25 / 1,0M	0,65	40	42
SSIH1005-R20	0,20	0,25 / 1,0M	0,65	30	40
SSIH1208-R15	0,15	0,1 / 500K	0,60	50	55
SSIH1208-R21	0,21	0,1 / 500K	0,60	45	50
SSIH1208-R26	0,26	0,1 / 500K	0,60	40	45
SSIH1208-R32	0,32	0,1 / 500K	0,60	40	41
SSIH1208-R44	0,44	0,1 / 500K	0,60	28	30

GERMANY

SCHMID-MULTITECH GmbH

Head Office
Waldweg 1
D 93105 Tegernheim
Tel: +49-9403-9510-0
Fax: +49-9403-4251
info@schmid-multitech.de

www.schmid-multitech.de

SCHMID-MULTITECH
GmbH

Branch Ziemendorf
Dorfstrasse 49g
D 39619 Ziemendorf
Tel: +49-39384-9848-0
Fax: +49-39384-9848-18
ziemendorf@schmid-multitech.de

CZECH Republic

ATD Elektronik s.r.o.
Luznice 10
CR 34401 Domazlice
Tel: +420-379 723 915
Fax: +420-379 725 868
mobil: +420-602 472 334
info@schmid-multitech.de

www.atd-elektronik.cz



HUNGARY

ADMM KFT
Rumi u.284
H 97000 Szombathely
Tel: +36-94-510 522
Fax: +36-94-510 523
mobil: +36-30-997 2514
mail@admm.hu

ADMM Kft

www.admm.hu

SLOVAK Republic

SCHMID-MULTITECH s.r.o.
Podjavorinskej 5
SR 91105 Trencin
Tel: +421-32-7440186
Fax: +421-32-7440187
mobil: +421-905-622597
rstraka@smsk.sk

www.smsk.sk



ROMANIA

ANGIELA ELEKTRONIK SRL
Str. Slanic Nr. 1 Ap.3
RO 400413 Cluj-Napoca
Tel: +40-264-403284
Fax: +40-264-403280
info@angiela-elektronik.ro

ANGIELA Elektronik s.r.l.

www.angiela-elektronik.ro

POLAND

ABC ELEKTRONIK sp.zoo.
Kolejowa 10
PL 38300 Gorlice
Tel: +48-18-3536665
Fax: +48-18-3536833
info@abcpol.pl

www.abcpol.pl



RUSSIA

ALFA ELEKTRONIK
pr.Gagarina, 50, kor.15, ofis 208
RUS 603057 Nizhnij Novgorod
Tel: +7-8312-649742
Fax: +7-8312-649742
sale@alfa-elektronik.com
ralfa@rol.ru

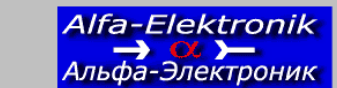

www.alfa-elektronik.com

UKRAINA

ALFA ELEKTRONIK
Kravtschenko 22,z.4
UKR 04050 Kiev
Tel: +380-44-4841990
Fax/Tel: +380-44-4868344
sales@alfacom-ua.net
alfacom@ukrpack.net

www.alfacom-ua.net

