

UBW-2W Series



2W 4:1 Regulated Single & Dual output

Features

- SMD 12Pin Package
- Wide 4:1 Input Range
- Full SMD Technology
- 3000 VDC Isolation
- Continuous Short Circuit Protection
- -40 ~ 75°C Operation Temperature Range
- Remote on/off Control
- Tape & Reel Package Available
- Under Voltage Lockout



The UBW-2W series is a family of cost effective single & dual output DC-DC converters. These converters are built in SMD 12PIN package with standard footprint. Devices operate 4:1 input voltage range providing stable output voltage. Input voltages of 12, 24 with output voltage of 5, 12, 15, ±12, ±15 Vdc.

All specifications typical at Ta=25°C, nominal input voltage and full load unless otherwise specified

OUTPUT SPECIFICATIONS	
Voltage Accuracy	±1%
Maximun Output Current	See table
Line Regulation	±0.2%, max.
Load Regulation	Single (From 0% to 100% Load) ±0.5%, max. Dual (From 0% to 100% Load) ±0.5%, max.
Cross Regulation (Dual Output) (1)	±5%
Ripple & Noise (20 Mhz bandwidth)(2)	100mVpp, max.
Short Circuit Protection	Indefinite (Automatic Recovery)
Temperature Coefficient	±0.02%/°C
Capacitive Load(3)	See table
Transient Recovery Time (4)	500us, typ.
Transient Response Deviation(4)	±3%, max.
INPUT SPECIFICATIONS	
Voltage Range	See table
Start up Time(Nominal Vin and constant resistive load)	30mS, typ.
Max. Input Current	See table
No-Load Input Current	See table
Input Filter	Capacitor
Input Reflected Ripple Current(5)	20mA pk-pk
Remote on/off	
ON:	open or high impedance
OFF:	2-4mA input current (via 1K)
Off stand by input current(Nominal Vin)	3.0mA, max.
Under Voltage Lockout	
12V Modes Module ON / OFF	4.1Vdc / 3.5Vdc, typ.
24V Modes Module ON / OFF	8.5Vdc / 7.0Vdc, typ.
GENERAL SPECIFICATIONS	
Efficiency	See table, typ.
I/O Isolation Voltage (tested for 60 sec)	3000Vdc
I/O Isolation Capacity	25 pF, typ.
I/O Isolation Resistance	1G Ohm, min.
Switching Frequency	100kHz, min.
Humidity	95%relH
Reliability Calculated MTBF (MIL-HDBK-217 F)	>890Khrs@25°C
Safety Standard(designed to meet)	IEC/UL/EN 60950-1 IEC/UL/EN 62368-1

PHYSICAL SPECIFICATIONS		
Base Material	Non-conductive Black Plastic (UL94V-0 rated)	
Pin Material	0.5mm C5191R-H Solder-coated	
Weight	2,0g, typ.	
Dimensions	0.58"x0.56"x0.35"	
ENVIRONMENT SPECIFICATIONS		
Operating Temperature	-40°C~75°C (For 100% Load)	
Storage Temperature	-55°C~125°C	
Cooling(6)	Nature Convection	
Lead-free Reflow Solder Process	IPC/JEDEC J-STD-020D.1	
Reflow Temperature	Peak 245°C(10 sec), max.	
Moisture Sensitivity Level (MSL)	IPC/JEDEC J-STD-020D.1 Level 1	
Vibration	MIL-STD-810F	
ABSOLUTE MAXIMUM RATINGS(7)		
These are stress ratings. Exposure of devices to any of these conditions may adversely affect long-term reliability.		
Input Surge Voltage(100ms max)		
12 Models	25Vdc, max.	
24 Models	50Vdc, max.	
EMC CHARACTERISTICS		
Radiated Emissions	EN55032	CLASS A
Conducted Emissions(8)	EN55032	CLASS A
ESD	IEC61000-4-2	Perf. Criteria A
RS	IEC61000-4-3	Perf. Criteria A
EFT(9)	IEC61000-4-4	Perf. Criteria A
Surge(9)	IEC61000-4-5	Perf. Criteria A
CS	IEC61000-4-6	Perf. Criteria A
PFMF	IEC61000-4-8	Perf. Criteria A

UBW - 2W 4:1 Regulated Single & Dual output

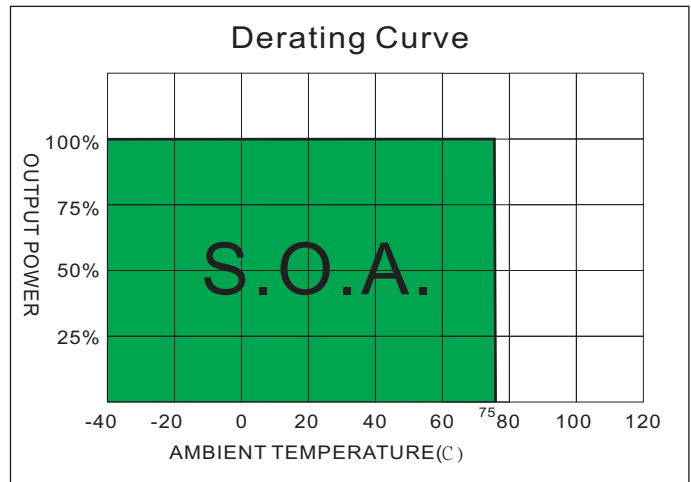
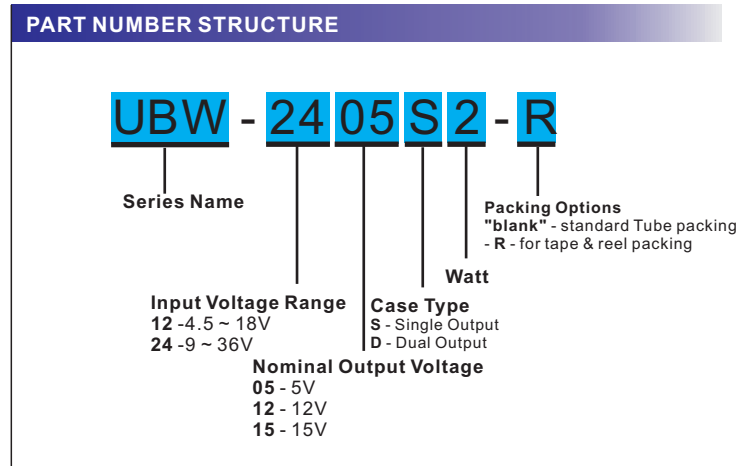

MODEL SELECTION GUIDE

MODEL NUMBER	INPUT Voltage Range (Vdc)	INPUT Current		OUTPUT Voltage (Vdc)	OUTPUT Current		EFFICIENCY @FL (% ,typ.)	Capacitor Load @FL (µF,max.)
		No-Load (mA,max.)	Full Load (mA,typ.)		Min load (mA)	Full load (mA)		
UBW-1205S2	12 (4.5-18)	50	214	5	0	400	78	1000uF
UBW-1212S2	12 (4.5-18)	50	211	12	0	166.7	79	220uF
UBW-1215S2	12 (4.5-18)	50	206	15	0	133.3	81	100uF
UBW-1212D2	12 (4.5-18)	50	211	±12	0	±83.3	79	±100uF
UBW-1215D2	12 (4.5-18)	50	206	±15	0	±66.7	81	±47uF
UBW-1205S2-R	12 (4.5-18)	50	214	5	0	400	78	1000uF
UBW-1212S2-R	12 (4.5-18)	50	211	12	0	166.7	79	220uF
UBW-1215S2-R	12 (4.5-18)	50	206	15	0	133.3	81	100uF
UBW-1212D2-R	12 (4.5-18)	50	211	±12	0	±83.3	79	±100uF
UBW-1215D2-R	12 (4.5-18)	50	206	±15	0	±66.7	81	±47uF
UBW-2405S2	24 (9-36)	30	107	5	0	400	78	1000uF
UBW-2412S2	24 (9-36)	30	105	12	0	166.7	79	220uF
UBW-2415S2	24 (9-36)	30	103	15	0	133.3	81	100uF
UBW-2412D2	24 (9-36)	30	105	±12	0	±83.3	79	±100uF
UBW-2415D2	24 (9-36)	30	103	±15	0	±66.7	81	±47uF
UBW-2405S2-R	24 (9-36)	30	107	5	0	400	78	1000uF
UBW-2412S2-R	24 (9-36)	30	105	12	0	166.7	79	220uF
UBW-2415S2-R	24 (9-36)	30	103	15	0	133.3	81	100uF
UBW-2412D2-R	24 (9-36)	30	105	±12	0	±83.3	79	±100uF
UBW-2415D2-R	24 (9-36)	30	103	±15	0	±66.7	81	±47uF

NOTE

- One load is 25% to 100% load, the other load is 100% load, the output voltage variable rate is within ±5%.
- Ripple/Noise measured with a 10uF electrolytic capacitor and 1.0uF ceramic capacitor.
- Test by minimal Vin and constant resistive load.
- Test by nominal Vin and 100%-25% load, 25% load step change.
- Measured Input reflected ripple current with a simulated source inductance of 12uH and a source capacitor Cin(47uF, ESR<1.0Ω at 100KHz).
- "Nature Convection" is usually about 30-65 LFM but is not equal to still air (0 LFM).
- Exceeding the absolute ratings of the unit could cause damage. It's not allowed for continuous operating ratings.
- Input filter components are required to help meet conducted emission and radiated emission class A,
- An external filter capacitor is required if the module has to meet IEC61000-4-4 and IEC61000-4-5.
The filter capacitor SCHMID-M suggest: Nippon - chemi - con KY series

TEST CONFIGURATIONS

Output Ripple & Noise Measurement Test

Use a 10 μ F electrolytic capacitor and 0.1 μ F ceramic capacitor.
The Scope measurement bandwidth is 20MHz.

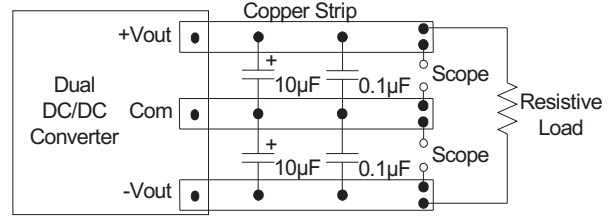
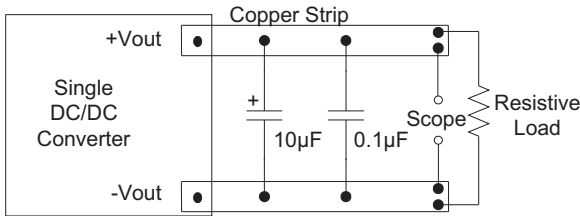

Input Reflected Ripple Current Test Step

Input reflected ripple current is measured through a source inductor L_{in} (12 μ H) and a source capacitor C_{in} (47 μ F, ESR<1.0 Ω at 100KHz) at nominal input and full load.

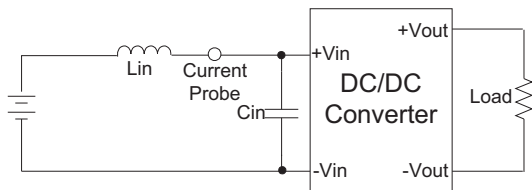

Remote ON / OFF Test Step

Input current(2~4mA) via 1K Ω to Pin3 , converter OFF. open or high impedance , converter ON.

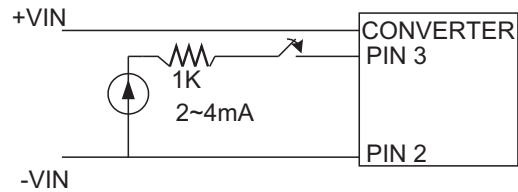

EFT/ Surge Filter

Input filter components (C1) is used to help meet IEC61000-4-4 and IEC61000-4-5 .

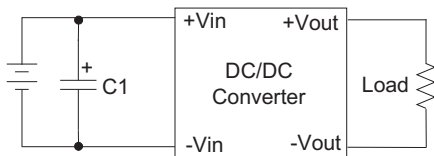

	C1
UBW-12XXX2	330 μ F,100V
UBW-24XXX2	330 μ F,100V

EMI Filter(Conducted Emissions)

Input filter components (C1~C7,L) are used to meet EMI test criterial A. These components should be mounted as close as possible to the module; and all leads should be minimized to decrease radiated noise.

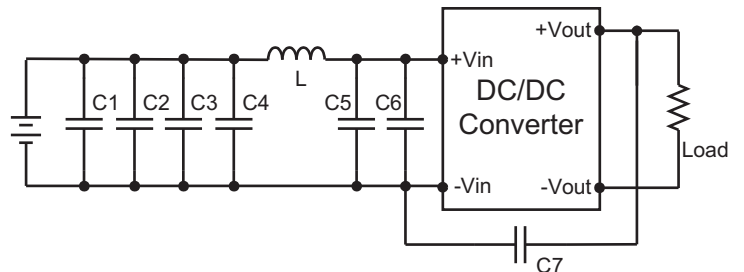

	C1	C2~C6	L	C7
UBW-12XXX2	1206, 10 μ F/50V		2.2 μ H	1808, 100pF/3KV
UBW-24XXX2	1206, 10 μ F/50V	1206, 10 μ F/50V	47 μ H	1808, 100pF/3KV

UBW - 2W 4:1 Regulated Single & Dual output

MECHANICAL SPECIFICATIONS

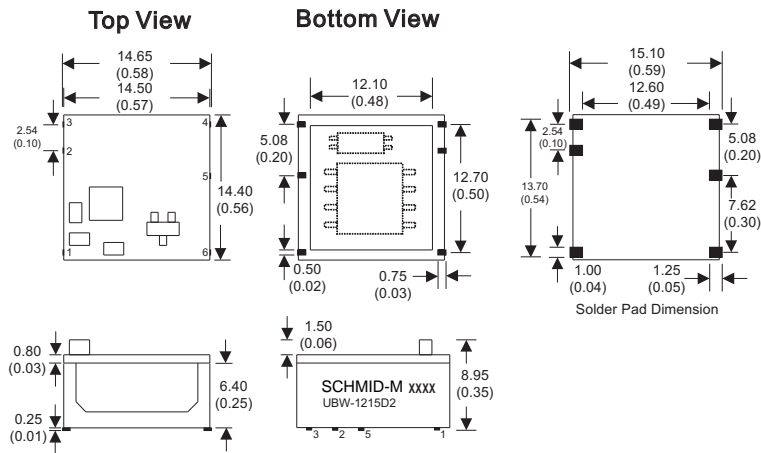

PIN CONNECTIONS		
PIN NUMBER	SINGLE	DUAL
1	+V Input	+V Input
2	-V Input	-V Input
3	Remote On/Off	Remote On/Off
4	+V Output	+V Output
5	N.C.	Common
6	-V Output	-V Output

SMD 12 Pin Package

- Notes : All dimensions are typical in millimeters (inches).
 1. Not marked Tolerances: ± 0.25 (± 0.01)
 2. N.C = No Connection

Tube dimension

Standard packing - Tube

■ 1 Tube contains 30 converters

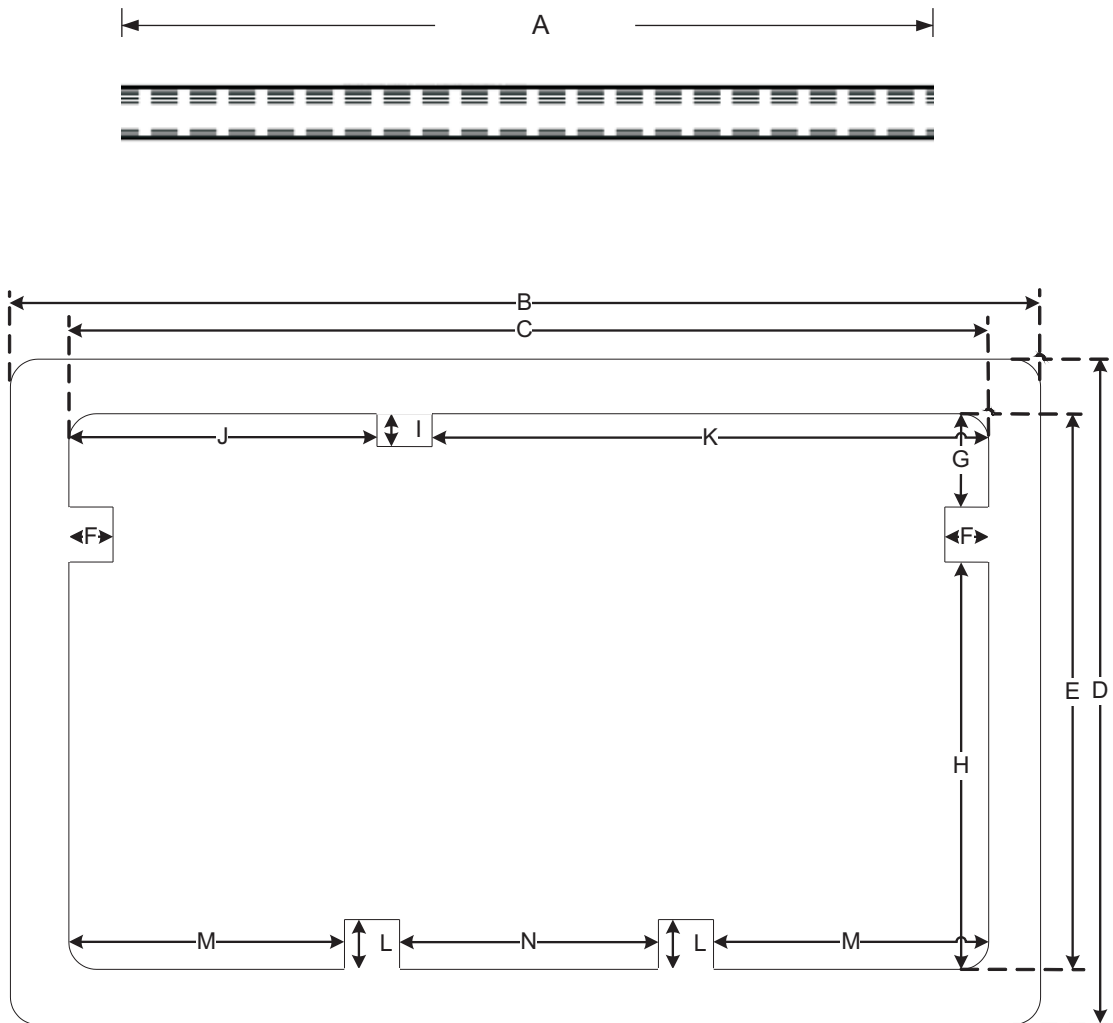

Dimensions in [mm]

Tube Length : 465 1.0 mm														
ITEM	A		B		C		D		E		F		G	
DIM	465	+1.0 -1.0	18.7	+0.25 -0.25	16.7	+0.25 -0.25	12.1	+0.25 -0.25	10.1	+0.25 -0.25	0.8	+0.1 -0.1	1.7	+0.25 -0.25
ITEM	H		I		J		K		L		M		N	
DIM	7.4	+0.25 -0.25	0.6	+0.1 -0.1	5.6	+0.25 -0.25	10.1	+0.25 -0.25	0.9	+0.1 -0.1	5	+0.25 -0.25	4.7	+0.25 -0.25

Tape & Reel dimension

Optional packing - Tape & Reel

- Specifications shall conform with current EIA-481 standard
- 1 Reel contains 200 converters
- Use appendix <<-R>> on order code

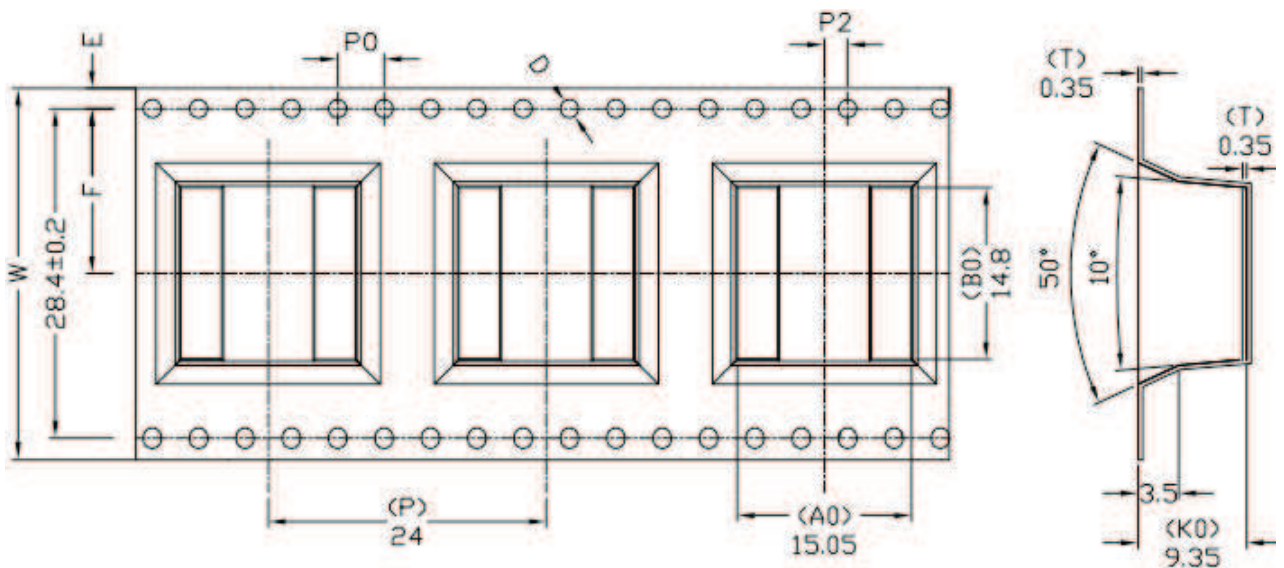
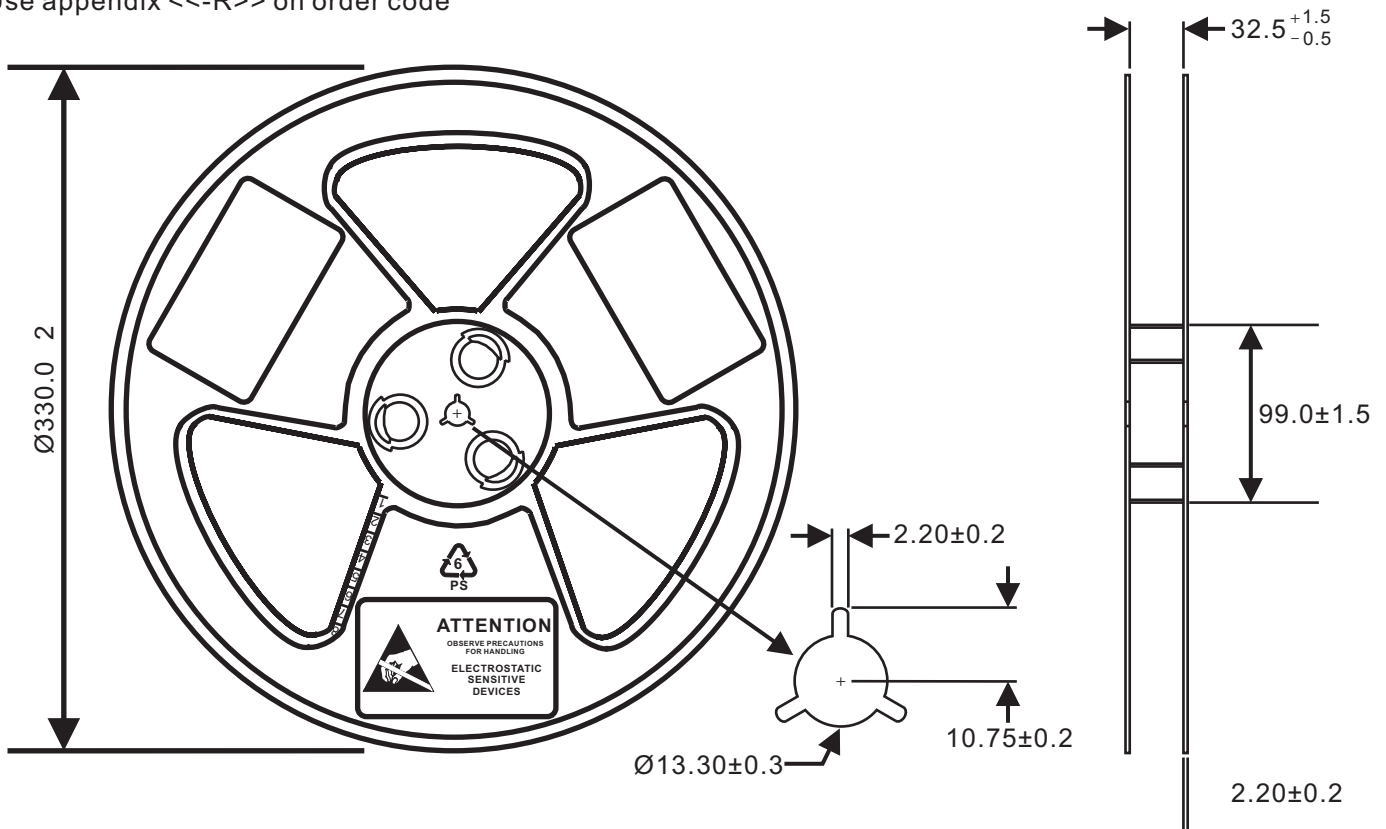

ITEM	W	A0	B0	K0	T	P	F	E	D	P0	P2
DIM	32.0	15.05	14.8	9.35	0.35	24	14.2	1.75	1.50	4.00	2.00
	+0.30 -0.30	+0.20 -0.10	+0.20 -0.10	+0.20 -0.10	+0.05 -0.05	+0.10 -0.10	+0.15 -0.15	+0.10 -0.10	+0.10 -0.00	+0.10 -0.10	+0.10 -0.10

dimensions in [mm]