

1. How to order:

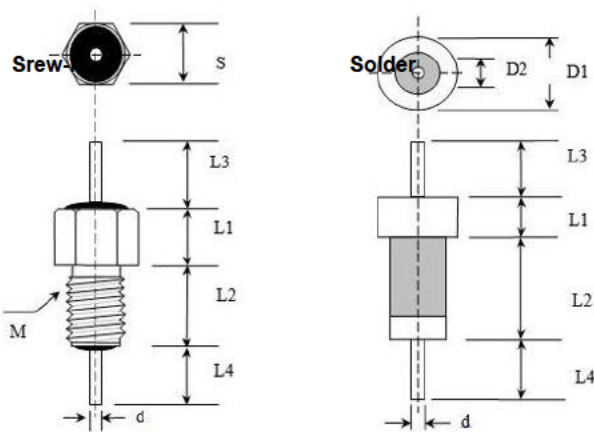

Sample Chart

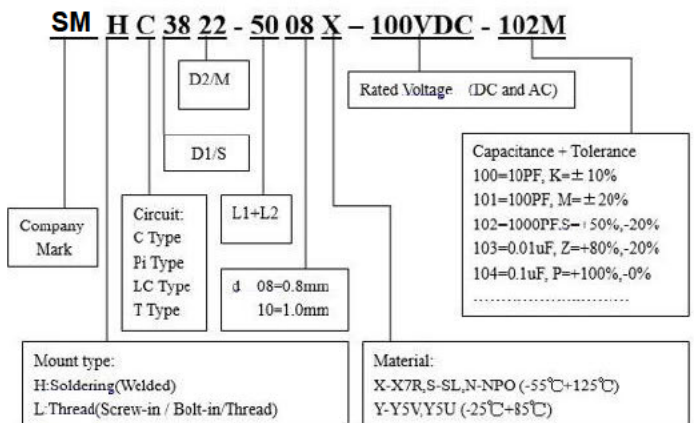

For example:

Together them, so get out: **SM-HC3822-5008X-100VDC-102Z**

Soldering Mount Feedthrough Capacitor (H)

C type Circuit (C)

D1 is 3.8mm (38)

D2 is 2.2mm (22)

Body width (L1: 1.5mm + L2: 3.5mm) is 5.0mm (50)

Lead dia (d) is 0.8mm (08)

Ceramic Material: X7R (X)

Rated voltage is 100VDC, (100VDC)

Capacitance is 1000pF (102)

Capacitance tolerance is +80%/-20% (Z)

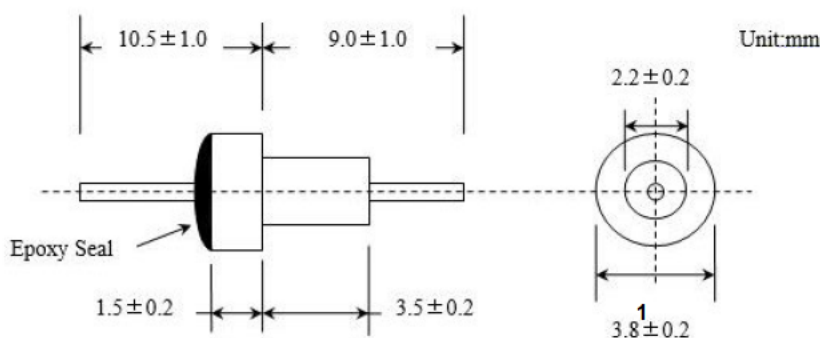

Custom design is available.
Free samples are supplied.

www.schmid-m.eu

2. Part of Applications

1. Energy Management Systems
2. Computers
3. Automatic Lighting
4. AM Radio Equipment
5. Factory Automation Equipment
6. Implantable Medical Devices(Cochlear Implants,Cardiac Pacemakers,etc.)
7. Military / Space Electronic Modules
8. Radio Controls
9. Telecommunications
10. Televisions and Monitors
11. Laboratory Equipment

3. Electrical Configuration:

A number of different electrical configurations are available in EMI filters,including the common types shown opposite.A single element filter(a capacitor or an inductor) theoretically provides an insertion loss characteristic of 20dB per decade,a dual element filter(capacitor and inductor) 40dB per decade whilst a triple element filter(Pi or T configuration) theoretically yields 60dB per decade.In practise,the insertion loss curves do not exactly match the predictions.and the data of electrical configuration is made primarily on the source and load impedances and may also be influenced by the level of attenuation required at various frequencies.

C Filter

This is a feedthrough capacitor with low(hardly) inductance.It shunts high frequency noise to ground and is suitable for use with a high impedance source and load.

LC Filter

This is an EMI filter with an inductance element in combination with a capacitor.It is commonly used in a circuit with a low impedance source and a high impedance load(or vice versa).

Pi Filter

This is an EMI filter with 2 capacitors and an inductive element between them.Ideally,it should be used where both source and load impedances are high.

T Filter

This is an EMI filter with 2 series inductive elements separated by one feedthrough capacitor.It is suitable for use where both source and load impedances are low.

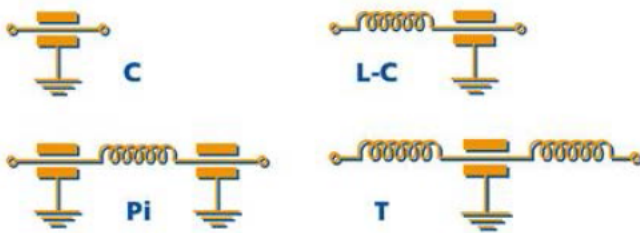

4. Source and load impedances

Insertion loss figures are normally publishes for a 50 Ohms source and 50 Ohms load circuit.In practice the impedance values will probably be very different,which could result in either an increase or decrease in insertion loss.The electrical configuration of the filter(the capacitor/inductor combination) should be chosen to optimize the filter performance for that particular source/load impedance situation.An estimate of insertion loss for source and load impedance other than 50 Ohms can be supplied.Please contact our Sales Office.

5. Bolt Mount EMI Filter (Bolt-in Filter)

Bolt Mount EMI Filters provide increased filtering in HF through MICROWAVE frequency spectrums from 100KHz through 10 GHz. The larger hex size means that much higher values of capacitance are available and that a 125 VAC/400 Hz rating is available in certain values. Also designed for mounting in a tapped bulkhead to with the standard nut and lock washer provided, it is optimum in medium to low impedance circuits where significant amounts of capacitance to ground can be tolerated. In the "L" and "Pi" section versions an internal ferrite bead element provide both inductance and series resistance (lossy characteristic) which improves the insertion loss rolloff to 40dB and 60dB per decade respectively.

Note:

1. Pi design offers steeper insertion loss rolloff.
2. Features rugged monolithic discoidal capacitor construction.
3. Epoxy seal on both ends.

Example:

SM-LPi5040-13508X-100VDC -332Z

Technical parameter:

1. Rated Voltage: 100VDC
2. Rated Current: 10A
3. Capacitance and Tolerance: 3300PF +80%, -20% Z
4. Insulation Resistor: >10000M Ohms
5. Dissipate Factor: <3.5%
6. Withstand Voltage: 200VDC, one minute No Short Circuit, No Failure.
7. Temperature Feature: -55 °C to +125 °C
8. Circuit : Pi Type
9. Dimension Tolerance: L±0.5mm, W±0.2mm, M / d±0.1mm

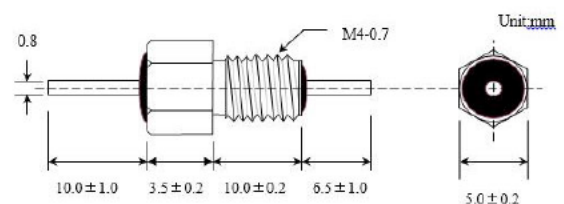

The thread stocks we have M2.5, M3, M4, M5, M6, M8, M10 and UNC UNF as follows:

Part No.	Dimension							Ci	Cap	Tol	Cu	Vol	Diel
	S	M	D	L	L1	L2	L3						
SM-L8-32UNC-2A-001	5	8-32UNC-2A	0,8	28,3	5,4	1,7	12,5	PI	1500pF*2	Z	7A	100VDC	X7R
SM-L8-32UNC-2A-002	5	8-32UNC-2A	1	28,3	5,1	1,52	12,5	C	1000pF	P	10A	100VDC	X7R
SM-L8-32UNC-2A-003	5	8-32UNC-2A	1	28,3	5,1	1,52	12,5	C	2000pF	Z	10A	100VDC	Y5U
SM-L8-32UNC-2A-004	5	8-32UNC-2A	1	28,3	5,1	1,52	12,5	C	1500pF	Z	10A	100VDC	X7R
SM-L8-32UNC-2A-005	5	8-32UNC-2A	0,8	30,3	9,2	2,4	6	PI	1500pF*2	z	7A	200VDC	X7R
SM-L1/4-28UNF-2A-001	9,77	1/4-28UNF-2A	1	15,6	7,9	3,2	3,9	L	1,4uF	M	10A	50VDC	X7R
SM-L1/4-28UNF-2A-002	9,77	1/4-28UNF-2A	1	35	19	14,3	10	PI	0,6uF*2	M	10A	50VDC	X7R
SM-L1/4-28UNF-2A-003	10	1/4-28UNF-2A	1,5	38,4	29,8	25	4,83	6F	1uF*3	Z	3A	50VDC	X7R
SM-L1/4-28UNF-2A-004	9,77	1/4-28UNF-2A	1	35	19	14,3	10	PI	1uF*2	M	10A	50VDC	X7R
SM-L12-28UNF-2A-001	6	12-28UNF-2A	1,2	25,4	12	4	6,35	C	0,01uF	Z	15A	250VDC	X7R
SM-L6-32UNC-2A-001	4	6-32UNC-2A	0,8	30,3	9,1	3,2	8	LC	330pF	Z	10A	200VDC	X7R

1. Just the dimension above the chart, it is our stocks in our house, and if you have your own dimension request, you can email us that we will open the new models for you, sure, as long as you have the large quantity, we will open the free one for you, if you have order a little, you have to pay some model fee.

2. Voltage: As the above chart, it is only marks the DC, In fact, we also can produce the AC for you as long as your appliance need it.

3. Planting number on the surface, please show your word details.

Capacitance: measured @ 1KHz and .1 to 1 VRMS, 25 °C

Dissipation factor: 3.5% max.

Dielectric withstanding voltage: 200% of WVDC min.

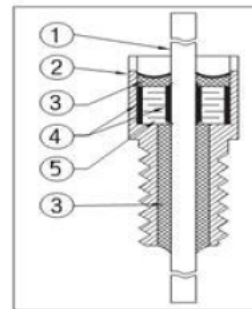

- ① LEAD
- ② CASE / SHELL
- ③ EPOXY
- ④ SOLDER
- ⑤ CAPACITOR

Insulation Resistance: 10,000 Mohms min. @ 25 °C, WVDC; 1000 Mohms min. @ 125 °C WVDC

6. Solder Mount EMI Filter (Solder-in Filter)

Solder Mount EMI Filter is intended for use as a high reliability alternative a commonly available commercial filter type, Due to its smaller body diameter, capacitance is limited. It does provide effective filtering in the MICROWAVE frequency spectrum from 100MHz through 10GHz. Designed to be soldered into a package, bracket or bulkhead (and maintain hermeticity), it is ideal for high impedance circuits where large capacitance values are not practical.

Alternate lead lengths or special capacitance values are available upon request.

Custom package to bracket assemblies utilizing this feedthru can be furnished to your specifications.

Note:

1. Epoxy seal on both ends.

Example:

SMHC3822-5008X-100VDC -102Z

Technical parameter:

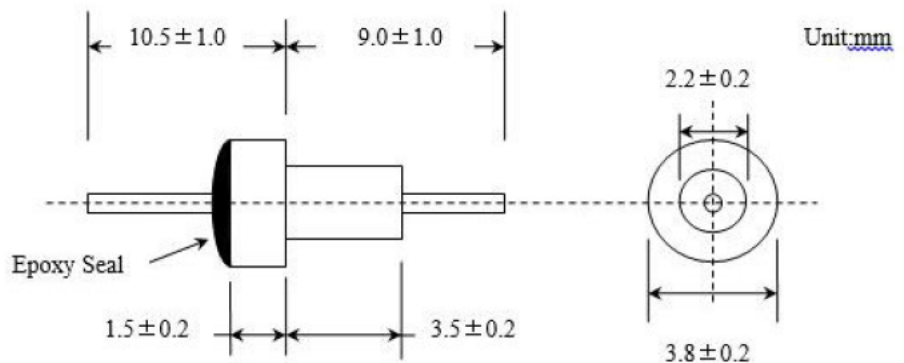

1. Rated Voltage: 100VDC
2. Rated Current: 7A
3. Capacitance and Tolerance: 1000PF +80%, -20%
4. Insulation Resistor: >3000M Ohms
5. Dissipation Factor: <3.5%
6. Withstand Voltage: 200VDC, one minute No Short Circuit, No Failure.
7. Temperature Feature: -55 °C to +125 °C
8. Circuit Type: C Type
9. Dimension Tolerance: L±0.5mm, D±0.2mm, d±0.1mm

SCHMID-M

www.schmid-m.eu

The soldering parts we had a lot, please contact with us if you are interesting.

7. Multilayer EMI Filter Chips

.Feature and Appliance

- 1.Small volume,large capacitance,small capacitance change;
- 2.Used to manufacture kinds of EMI Filter and related components;
- 3.Used to prevent RF interference of by pass and filter,have some features of different rated voltage、 kinds of temperature feature and outdrawing dimensions,so it fit for aerospace equipment,consumer electronic devices;
- 4.Temperature Feature:-55°C to +125°C. Electrical Properties

Item	Dimension		W.V.Cap Range	Cap.Tol	I.R.	D.F.	Temp Coef/Feat
	ΦD	Φd	100VDC				
CC52-Φ2.5	2.5±0.2	0.9±0.10	3R3~103	M	$R_i \geq 10^4 M\Omega$	$\leq 15 \cdot 10^{-4}$	BC Feature: (0±30) $\cdot 10^{-6}/^\circ C$
CC52-Φ4.3	4.3±0.2	1.2±0.15	4R7~103				
CC52-Φ4.8	4.8±0.2	1.2±0.15	4R7~103				
CT52-Φ2.5	2.5±0.2	0.9±0.10	102~223	M	$C_R \leq 25nF$ $R_i \geq 5 \cdot 10^4 M\Omega$ $C_R \geq 25nF$ $R_i \cdot C_R \geq 100s$	≤ 0.035	2X1 Feature: $\leq \pm 15\%$
CT52-Φ4.3	4.3±0.2	1.2±0.15	102~513				
CT52-Φ4.8	4.8±0.2	1.2±0.15	102~753				
CT52-Φ6.5	6.5±0.2	1.9±0.20	103~184				
CT52-Φ8.2	8.2±0.2	1.6±0.20	104~684				
CT52-Φ9.0	9.0±0.2	1.9±0.20	104~824				

Chips' Thickness,up to the clients request.

a.W.V.Cap Range:Working Voltage Capacitacne Range;

Custom design is available.

b.Cap.Tol:Capacitance Tolerance(M=+/-20%);

Order samples:

c.I.R.:Insulation Resistance;

SM - CT52-Φ2.5-2X1-100VDC-223-M

1 2 3 4 5 6

d.D.F.:Dissipation Factor;

1 -Item 2-Dimension Part 3-Temperature Coefficient/Feature

e.Temp Coef/Feat:Temperature Coefficient/Feature.

4-Rated Voltage(W.V.:Working Voltage) 5- Capacitance
6 Cap Tolerance

8. Insertion Loss Measurement

Insertion Loss(IL) is a measure of the effectiveness of a filter.it is defined as the ratio of the voltage(E1) across the circuit load without the filter and the voltage(E2) across the load with the filter.Since insertion loss is dependent on the source and load impedance in which the filter is to be used,IL measurement are defined for a matched 50ohms system.The insertion loss is measure in decibels(dB) and defined as follows:

$$IL(dB) = 20 \log [E1 / E2]$$

Circuit Impedance VS. Insertion loss

In practical circuit applications the source and load impedances may be quite different from 50ohms.If these impedance are known,Xiangwei Engineering can provide information on the expected Insertion Loss or an estimate can be made using the following formula:

$$IL(dB)=20\log[1+Z_sZ_l / Z_t (Z_s+ Z_l)]$$

Where Z_s =Source impedance in ohms, Z_l =Load impedance in ohms, Z_t =Transfer impedance in 50ohms.

Example:

1. System source and load impedance are 100ohms and 600ohms respectively.
2. Selected filter has insertion loss of 50dB at 100 MHz in a 50ohms system.
3. From the IL VS Transfer Impedance curve(right) the transfer impedance is 0.08ohmz.
4. $IL = 20\log[1+100*600 / 0.08*(100+600)] = 20 \log 1072 = 61dB$

9. Miniature EMI Filter

SM-HC4033-2808S-100VDC-101M

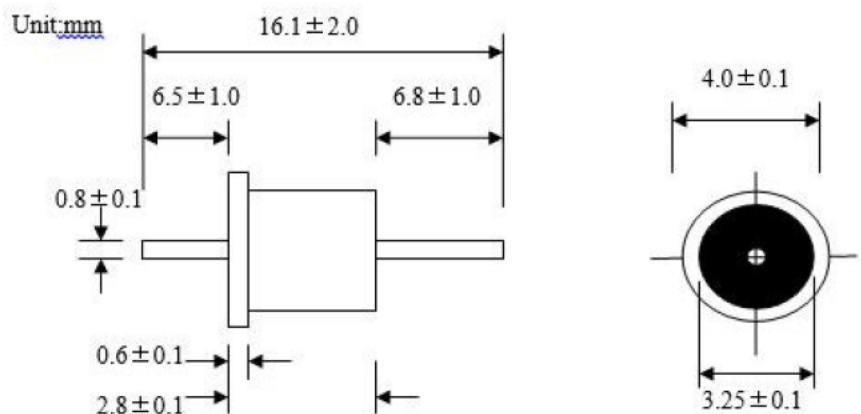

Technical parameter:

1. Rated Voltage:100VDC
2. Rated Current:5A
3. Capacitance and Tolerance:100PF $\pm 20\%$
4. Insulation Resistor:>3000M Ohms
5. Dissipate Factor:<3.5%
6. Withstand Voltage:200VDC, one minute No Short Circuit,No Failure.
7. Temperature Feature:-55 °C to +125 °C
8. Circuit Type:C Type

The capacitance will be arranged from 10PF to 1uF,the high capacitance only has low rated voltage,and the different materials(SL,NPO,X7R Y5U Y5V Y5P...) depend on the capacitors electric feature.

The capacitance will be arranged from 10PF to 1uF, the high capacitance only has low rated voltage, and the different materials (SL, NPO, X7R, Y5U, Y5V, Y5P...) depend on the capacitors electric feature.

10. MAX Mounting Torque:

Mounting torque

It is important to mount the filter to the bulkhead or panel using the recommended mounting torque, otherwise damage may be caused to the capacitor due to distortion of the case. When a threaded hole is to be utilised, the maximum mounting torque should be 50% of the specified figure which relates to unthreaded holes. For details of torque figures for each filter range, please see below.

Thread	Torque (max.)	
	With nut	Into tapped hole
M2.5 & 4-40 UNC	-	0.15Nm (1.32lbf in)
M3	0.25Nm (2.21lbf in)	0.15Nm (1.32lbf in)
6-32 UNC	0.3Nm (2.65lbf in)	0.15Nm (1.32lbf in)
M3.5	0.35Nm (3.09lbf in)	0.18Nm (1.59lbf in)
M4 & 8-32 UNC	0.5Nm (4.42lbf in)	0.25Nm (2.21lbf in)
M5, 12-32 UNEF & 2BA	0.6Nm (5.31lbf in)	0.3Nm (2.65lbf in)
M6 & 1/4-28 UNF	0.9Nm (7.97lbf in)	-

EMI Filter dielectric feature

EMI Filter:

The capacitor used in Filter just as ceramic EMI filter. It also called Feed-thru Capacitors, Feed Through Capacitor, Feed-thru Filter, Feed Through Filter, Feed-thru Condenser, EMI Feedthru. because of its physical structure.

Feed-thru Capacitor's inductance smaller than usual capacitor, so resonance frequency by itself are high. meanwhile, it prevents the high frequency signal direct couple from input to output for Feed Through design. It supply better depression effect during frequency 1GHz because of low-pass together with high-cut.

It is the most simple of feed through structure that connect internal and external electrode with ceramic form one (C type) or two capacitor (Pi type). The capacitance arrange from 10PF to 4700PF, the rated voltage can achieve 2000VDC. Discoidal Capacitor didn't show apparent resonance frequency by itself at 10GHz, because it has the coaxial structure.

Feed-thru Capacitor's dielectric is ceramic, but ceramic capacitor's capacitance will change by environmental temperature changeable, capacitance changeable will influence filter's cut-off coefficient of filter. The ceramic capacitor dielectric fix itsself capacitance temperature change. So select the adequate ceramic dielectric is very important. usual ceramic dielectric and its capacitance temperature change as follows:

Filter Inductor:

Filter inductor is used to ferrite materials, it can get together with the Feed-thru Capacitors conveniently, form the composite filter, in the field of high characteristic filter, it also uses wire-wound inductance. One point: Ferrite materials will appear magnetic saturation in high current, and reduce the filter function.

Filter Installation type:

H: Solder-in type Filter

L: Screw type Filter

EMI/RFI Filters feature and application:

Solder-in Filters:

- * Solder-in filters are the ideal component of the small stall space.
- * Application: used to filter signal, data wire and AC switch wire; telecommunication equipment, transmission equipment, microwave filter, Industrial Personal Computer, composite circuit filter assembly;
- * Small dimension: use the space effectively;
- * Rated Voltage: can achieve 750VDC;
- * Circuit type: C type, Pi type, L type.
- * Certification: MIL-F-15733 QPL and MIL-C-11015(CK99)

Epoxy seal bolt-in filters:

- * The recommended nut and washer fix on the screw hole space convenient for epoxy seal bolt-in filter;
- * It supplies the good environmental protection both the two ends epoxy seal.
- * Application: signal, data wire and DC switch wire filter; specially the miniature press-in and bolt-in install used in the unsoldering space, it fits for the microwave and high pass.
- * Rated voltage: can achieve 4000VDC/250VAC
- * Circuit type: C type, L type, Pi type
- * Certification: MIL-F-15733

High Current, High Voltage epoxy seal filters:

- * Application: High current filters used in high current switch power, DC charge system; High voltage filters used in high voltage power, the stable bolt structure fix easy.
- * Feature: High current can achieve 100Amps
- * Rated voltage: can achieve 4000VDC and 250VAC@400Hz

Glass seal miniature EMI Filters:

- * This filter uses the glass seal, has the nice EMI filter feature; it is the best choice that it needs the high stable filter in the rugged environment, will high frequency high stable EMI filter during 10KHz to 10GHz, glass seal series anti-moist, anti-corrosive, protect the filter nicely in the field of military affairs.
- * Application: power, signal wire, rocket ignition system, plane, military telecommunication, medical equipment, multiple-stage filter;
- * Stable: According to MIL-F-15733 and MIL-F-28861 standard manufacture, and fit for QPL request; the level of "S" aerospace usage.
- * Feature: Insertion Loss spread from 1MHz to 18GHz
- * Capacitance and Temp. Feature: 1.5uF NPO, X7R, Z5U
- * Temperature arrange: -55°C +125°C Max Voltage: 4000VDC 250VAC@400Hz
Max current: 30Amps