

RoHS Compliant

REV.	ECN. NO.	DR.	DATE
A	NEW	Jeff	120505

Ordering information:
 SM C07 1122452 X X X - 1

9:LCP
 ...
 9:Black
 ...

1:Tray
 ...

1:Gold Flash/Tin
 2:15u" Gold/Tin
 3:30u" Gold/Tin
 ...

NOTES:
 1.MATERIAL:
 HOUSING:LCP 30% G/F UL94 V-0
 COLOR:BLACK
 CONTACT:PHOSPHOR BRONZE C5191H T=0.25mm
 PEG:BRASS C2680H
 2.FINISH:
 CONTACT:15u" GOLD/TIN PLATING ON CONTACT AREA
 100u" MIN.TIN PLATING ON SOLDER TAILS
 50u" MIN.NICKEL UNDERPLATING OVER ALL
 PEG:100u"MIN.TIN PLATION ON SOLDER TAILS
 50u"MIN.TIN NICKEL UNDERPLATING OVER ALL

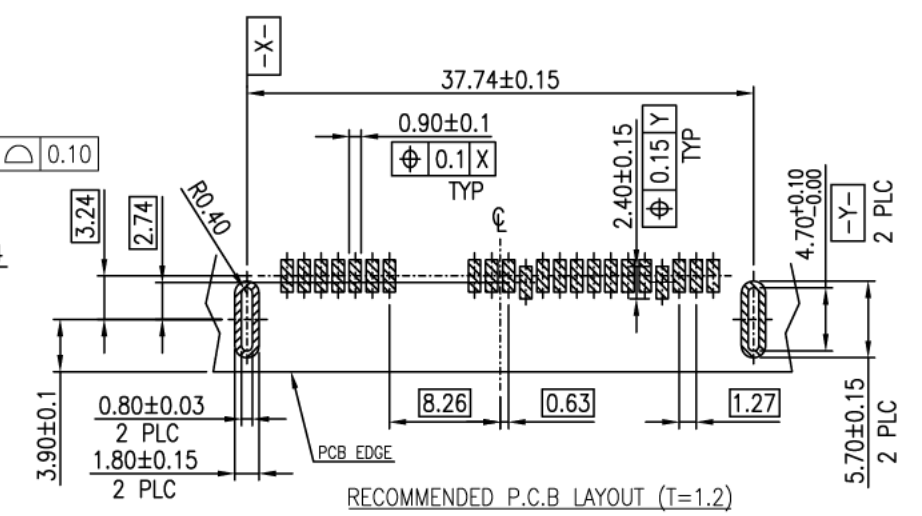
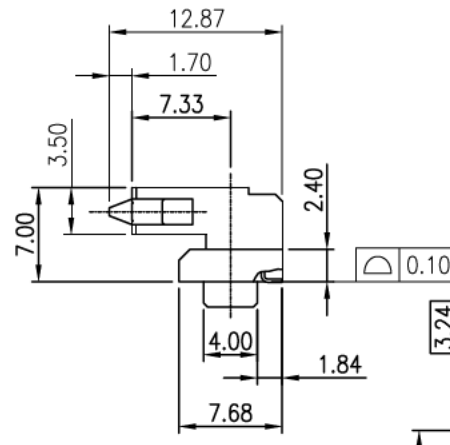
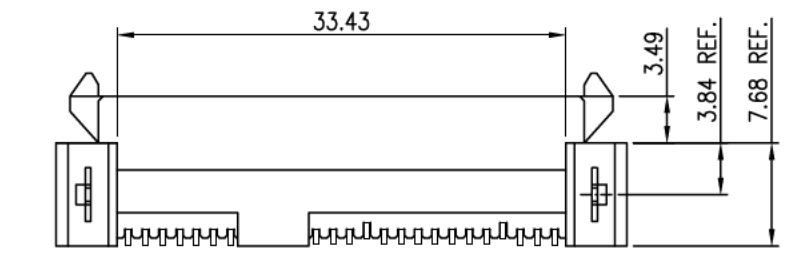
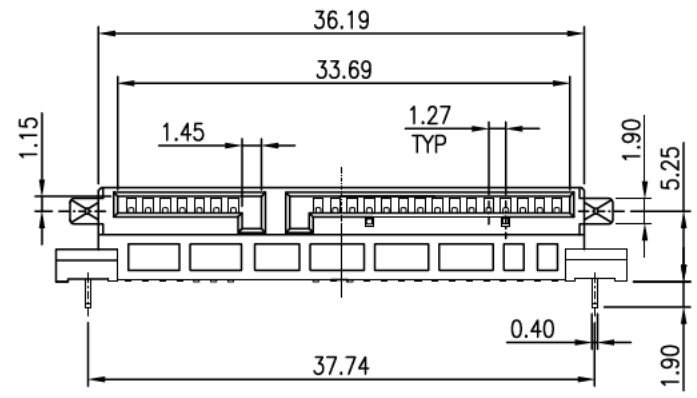
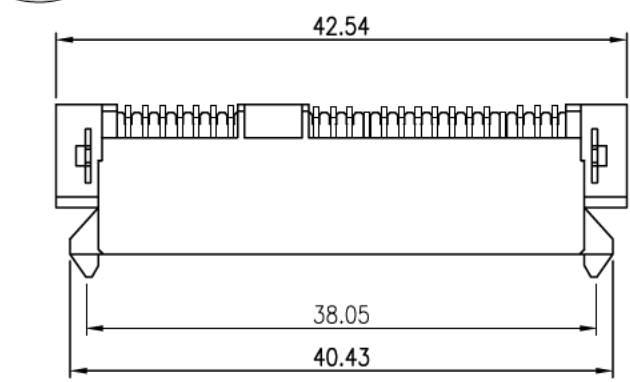

Title: SATA 7+15P 90° SMT H:7.00mm		SCHMID-M	
tolerances		app.	units
linear	angles	chk.	<input checked="" type="checkbox"/> mm <input type="checkbox"/> inch
.x ±0.38	x.' ±5'	dr.	size A4
.xx ±0.25	.x' ±2'	date.	scale 4:1
.xxx ±0.15	.xx' ±1'		sheet 1/1
projection	revision.		
	B		