

# 6: Extrusions



## 6.6 Height Divider Extrusions

### 6.6.1 Height Divider Extrusion 66-115

- Divider extrusion front
- **Scope of delivery:**
  - 1 height extrusion without assembly material

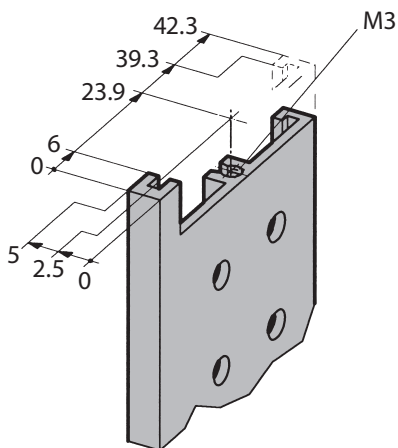

#### 6.6.1 Height Divider Extrusion 66-115

Length for U	Length		Length for M3		Part-No. clear anodised
	mm	inch	mm	inch	
3	129.1	5.08	112.7	4.44	66-115-21
6	262.4	10.33	246.0	9.68	66-115-25

### 6.6.2 Height Divider Extrusion 66-107

- Divider extrusion front
- **Scope of delivery:**
  - 1 height extrusion without assembly material

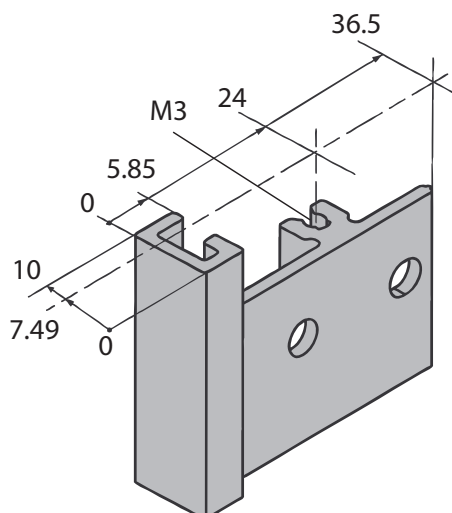

#### 6.6.2 Height Divider Extrusion 66-107

Length for U	Length		Length for M3		Part-No. clear anodised
	mm	inch	mm	inch	
3	129.1	5.08	112.7	4.44	66-107-44
6	262.4	10.33	246.0	9.68	66-107-47
9	395.4	15.7	379.2	15.7	66-107-49

# 6: Extrusions

## 6.6.3 Height Divider Extrusion 66-266

- EMC divider extrusion
- **Scope of delivery:**
  - 1 height extrusion without assembly material

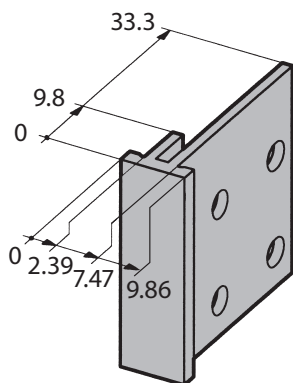

### 6.6.3 Height Divider Extrusion 66-266

Length for U	Length		Width	Part-No. clear passivated
	mm	inch		
6	261.8	10.30	2 HP	66-266-26

#### 6.6.3.1 EMC Contact Spring

- Stainless steel
- Side front panel end side panel
- EMC dividing extrusion 66-266

For Size	Length		Packing Units	Part-No.
	mm	inch		
3 U	107	4.28	4 pcs.	63-873-02
6 U	244.2	9.6	2 pcs.	63-873-05

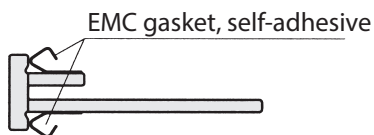
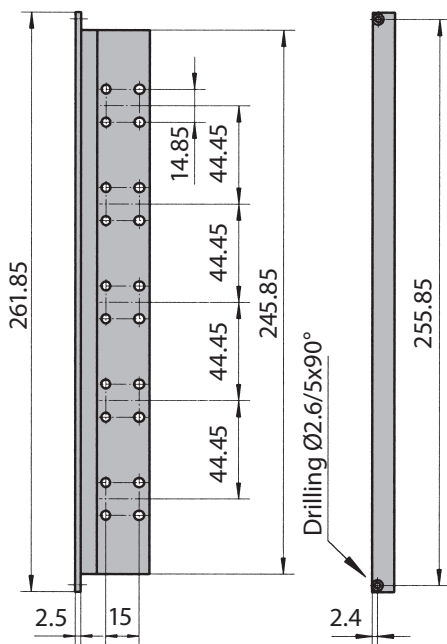

## 6.6.4 Height Divider Extrusion 66-116

- Divider extrusion rear
- **Scope of delivery:**
  - 1 height extrusion without assembly material

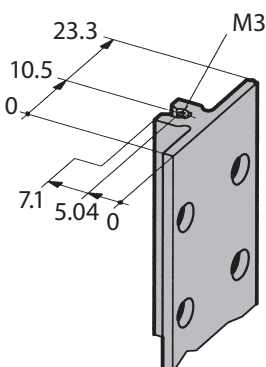

### 6.6.4 Height Divider Extrusion 66-116

Length for U	Length		Part-No. raw
	mm	inch	
4	157.0	6.17	66-116-45
6	245.9	9.68	66-116-47
9	379.2	14.92	66-116-49