

3: Handles

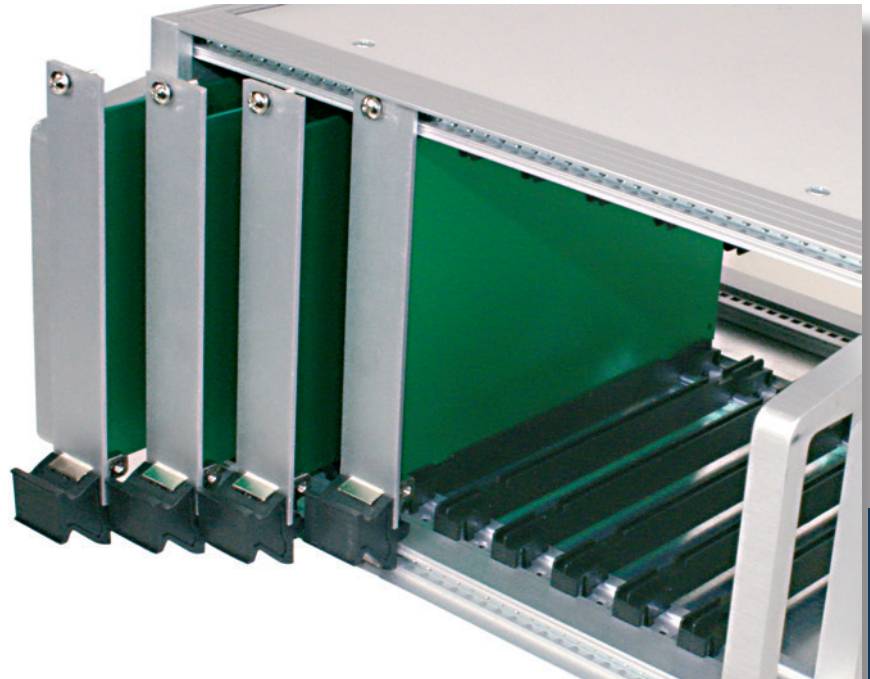

3.3 Ejector Handles acc. to IEC

- Simple assembly of plug-in units
- Allows trouble-free extraction of electronic units with multi-pole connectors
- Main features in one part: card holder, ejector handle and centring pin
- Reset spring for safe insertion
- One version for top and bottom only
- Handle is injection moulded, glass-reinforced plastic, UL94 V-0
- Card holder is zinc die-cast, nickel plated
- Reset spring is stainless steel
- **Scope of delivery:**
 - Ejector handle
 - Assembly material (cross recessed screws M2.5 for fixing of card holder/printed board/front panel)
- Front panel with special cutouts have to be ordered separately

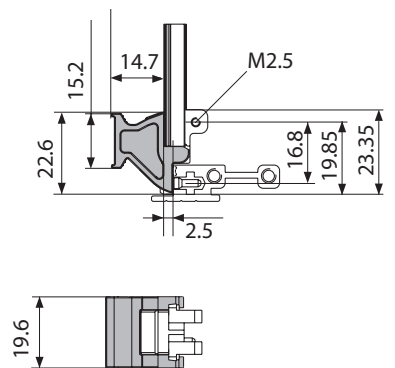

3.3 Ejector Handle acc. to IEC



Description	Part-No.
Ejector handle black	81-233
Ejector handle grey	81-234

Extraction process:

Restposition

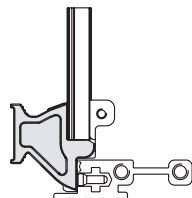

Extraction

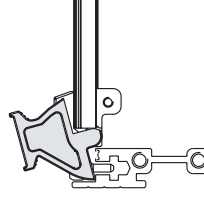

Endposition

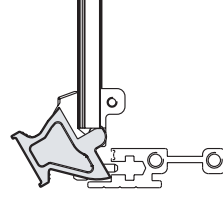

Label

Description	Part-No.
1 sheet A4 of 220 labels	81-031