

2: Front Panels for Plug-In Units

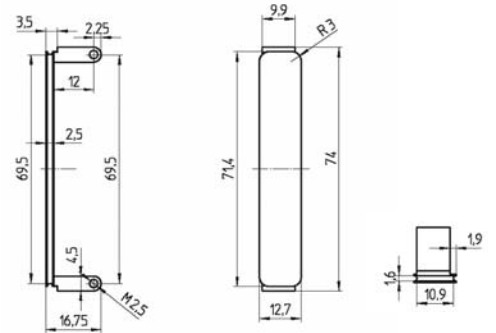

2.6 PMC Mezzanine Front Panels

- Acc. to IEEE 1386
- Used on VME-, Future, CPCI- or MultibusII-Boards when additional interfaces are needed
- On a double euro board (6 U / 4 HP) maximum two PCI mezzanine cards can be placed
- Two designs are available: Zinc die-cast or aluminium extrusion
- Mezzanine filler panel: To cover the unused Mezzanine cut outs. The filler panels are simply clipped into the cut outs.
- The EMC-gaskets can be inserted into the groove of the front panels
- **Scope of delivery:**
 - Mezzanine front panel
 - Gasket
 - Assembly Material (screws M2.5 x 6 mm)



Mezzanine Filler Panel

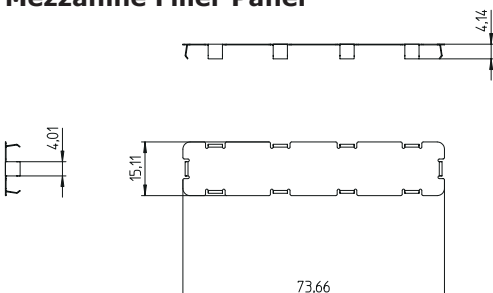

2.6 PMC Mezzanine Front Panels

Description	Material	Part-No. 10 pcs.
Mezzanine front panel incl. EMC-gasket	Zinc die-cast, chrome-plated	21M171-1
Mezzanine front panel incl. elastomer-gasket	Zinc die-cast, chrome-plated	21M172-1
Mezzanine front panel incl. EMC-gasket	Aluminium extrusion, clear anodised	21M271-1

Accessories

Description	Material	Part-No.
EMC-gasket (for zinc die-cast version)	Berilium copper	21M571-1 (10 pcs.)
Gasket (for zinc die-cast version)	Elastomer	21M572-1 (10 pcs.)
EMC-gasket (for aluminium profile version)	Elastomer mix with metal portion	21M570-1 (10 pcs.)
Mezzanine filler panel	Stainless steel	21M600-1 (10 pcs.)
Screws cross recessed M2.5 x 6 mm	Steel zinc plated blue	63-690 (20 screws)
Torx cylinder head screw M2.5 x 6, size T8	Stainless	5470-04 (1 screw)