

2: Front Panels for Plug-In Units



2.1 Plug-In Units acc. to IEC

2.1.1 Extruded Front Panel

- Aluminium 2.5 mm, clear anodised (non-conductive)
- PCB mounting lugs are formed on the rear face of the panel
- No PCB fixing screws on the front face of the panel, leaving more space for silk screening and mounting front panel components
- Suitable for all sub racks and cases
- Thickness of the mounting lugs (3.48 mm) allows PCBs to be mounted on either side of the lugs
- Drill marks at rear for handle-fixing holes
- **Scope of delivery:**
 - Extruded front panel, clear anodised
- Front panel screws see below

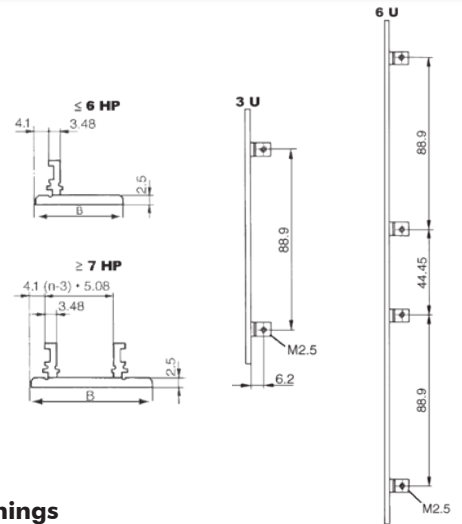

2.1.1 Extruded Front Panels, without Openings

Width	B		Part-No. 3 U	Part-No. 6 U
	mm	inch		
3 HP	15.0	0.59	26N303	26N603
4 HP	20.1	0.79	26N304	26N604
5 HP	25.2	0.99	26N305	26N605
6 HP	30.3	1.19	26N306	26N606
7 HP	35.3	1.38	26N307	26N607
8 HP	40.4	1.59	26N308	26N608
10 HP	50.6	1.99	26N310	26N610
12 HP	60.7	2.38	26N312	26N612
14 HP	70.9	2.79	26N314	26N614
16 HP	81.1	3.19	26N316	26N616
21 HP	106.5	4.19	26N321	-

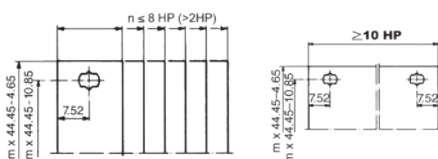

2.1.1.1 Front Panel Screws

- Set of 10 screws
- With screw retainer
- Front panel width up to 9 HP = 2 screws; ≥ 10 HP = 4 screws

Description	Part-No. 10 pcs.
Torx screws M2.5 x 11.3 , size T8, with plastic screw retainer	63K159
Rounded head screws recessed M2.5 x 11.3, with plastic screw retainer	63-159

2: Front Panels for Plug-In Units

2.1.1.2 Rigid-Mounted Unit Handles with Identification Label

- Black, plastic UL94 V-0, label aluminium anodised
- **Scope of delivery:**
 - Rigid-mounted handle
 - Identification label
- Assembly material see below

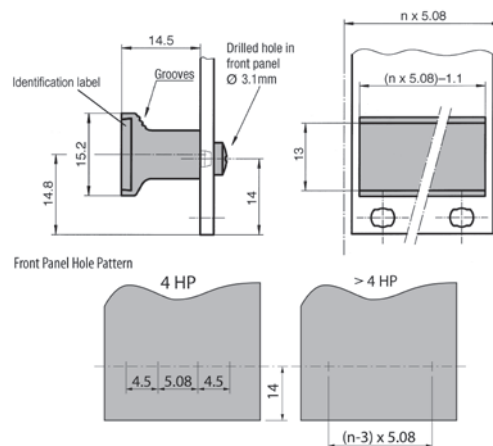

2.1.1.2 Rigid-Mounted Handle with Identification Label



Width	Scope of Delivery	Part-No.
4 HP	10 pcs.	60-200-04
5 HP	10 pcs.	60-200-05
6 HP	10 pcs.	60-200-06
7 HP	10 pcs.	60-200-07
8 HP	10 pcs.	60-200-08
10 HP	10 pcs.	60-200-10
12 HP	10 pcs.	60-200-12
14 HP	1 pc.	60-200-14

- Other sizes (up to 84 HP) are available upon request

Assembly Material

Description	Part-No.
Cross recessed rounded head screw	61-276

2.1.1.3 Fluted Handles

- Extruded aluminium handles, shaped to facilitate withdrawal of plug-in units
- Two grooves in the front face will accept identification strips (0.5 x 9 mm)
- **Scope of delivery:**
 - Extruded handle, clear anodised
 - Assembly material

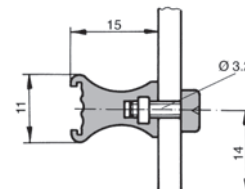

2.1.1.3 Fluted Handles for Front Panels to IEC



Front Panel Width HP	Width		Handle Length		Part-No.
	mm	inch	mm	inch	
3 HP	15.0	0.59	12.5	0.49	60-103
4 HP	20.1	0.79	17.6	0.69	60-104
5 HP	25.2	0.99	22.6	0.88	60-105
6 HP	30.3	1.19	27.7	1.09	60-106
7 HP	35.3	1.38	33.5	1.31	60-107
8 HP	40.4	1.59	37.9	1.49	60-108
10 HP	50.6	1.99	48.0	1.88	60-110
12 HP	60.8	2.39	58.2	2.29	60-112
14 HP	70.9	2.79	69.1	2.72	60-114
16 HP	81.1	3.19	78.5	3.09	60-116
21 HP	106.5	4.18	104.6	4.11	60-121
30 HP	152.2	5.99	149.6	5.88	60-130
40 HP	203.0	7.99	200.4	7.88	60-140
60 HP	304.6	11.99	302.0	11.88	60-160
84 HP	426.5	16.79	424.0	16.69	60-184

2: Front Panels for Plug-In Units

2.1.2 Front Panel with Cutout for IEC Ejector Handle

- Aluminium 2.5 mm, clear anodised (non-conductive)
- PCB mounting lugs are formed on the rear face of the panel (only 3 U-Version)
- No PCB fixing screws on the front face of the panel, leaving more space for silk screening and mounting front panel components
- Suitable for all sub racks and cases
- 3 U front panels prepared for one handle
- 6 U front panels prepared for two handles
- **Scope of delivery:**
 - Front panel, clear anodised
- Front panel screws see 2.1.2.1 (for 3 U-Version only)
- IEC ejector handles, see 2.1.2.2

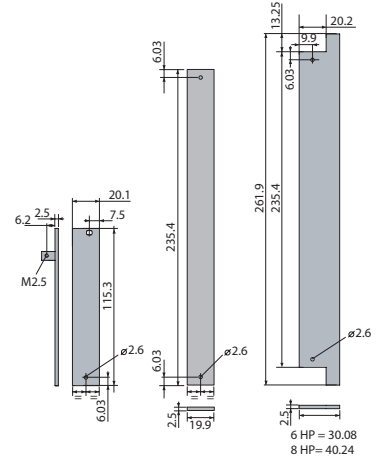

2.1.2 Front Panel with Cutout for IEC Ejector Handle

Width	B		Part-No. 3 U	Part-No. 6 U
	mm	inch		
4 HP	20.0	0.79	26N304-51	21N604-51
6 HP	30.2	1.19		21N606-51
8 HP	40.3	1.59		21N608-51

2.1.2.1 Front Panel Screws (for 3 U-Version only)

- Set of 10 screws
- With screw retainer
- Front panel 3 U = 1 screw

Description	Part-No. 10 pcs.
Torx screws M2.5 x 11.3, size T8, with plastic screw retainer	63K159
Rounded head screws recessed M2.5 x 11.3, with plastic screw retainer	63-159



2.1.2.2 Ergonomic Ejector Handles acc. to IEC

- Simple assembly of plug-in units
- Allows trouble-free extraction of electronic units with multi-pole connectors
- Main features in one part: card holder, ejector handle and centring pin
- Reset spring for safe insertion
- One version for top and bottom only
- Handle is injection moulded, glass-reinforced plastic, UL94 V-0
- Card holder is zinc die-cast, nickel plated
- Reset spring is stainless steel
- **Scope of delivery:**
 - Ejector handle
 - Assembly material (cross recessed screws M2.5 for fixing of card holder/printed board/front panel)
- Front panel with special cutouts have to be ordered separately

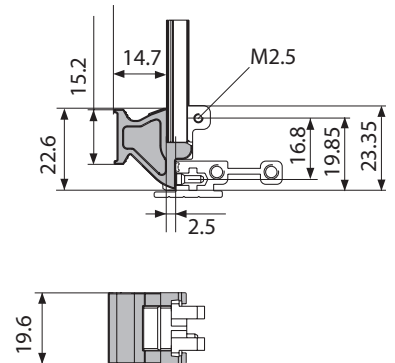

2.1.2.2 Ejector Handle acc. to IEC

Description	Part-No.
Ejector handle black	81-233
Ejector handle grey	81-234

Extraction process:

Rest position Extraction End position

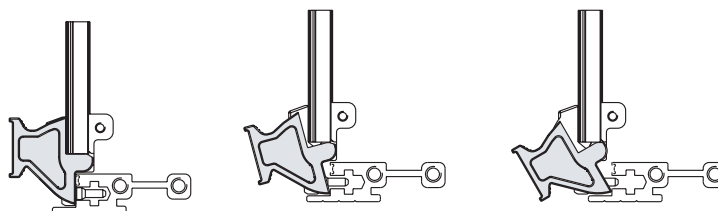

Label

Description	Part-No.
1 sheet A4 of 220 labels	81-031



2: Front Panels for Plug-In Units



2.2 EMC Plug-In Units acc. to IEC

2.2.1 EMC Filler Panel without Openings

- Excellent EMC shielding
- Made of aluminium extrusions
- Rear side: conductive surface finish (clear passivated)
- Used in the assembly of plug-in units
- The EMC-gasket is integrated into the front panel profile to protect it from damage
- A pressfit centering pin guarantees optimum positioning of the panel as well as the right pressure between the contact strip and the next panel

2.2.1 EMC Filler Panel without Openings

- High stability
- Extruded aluminium
- Pressed-in centring pin and bushes M2.5
- Front side clear anodised, rear side conductive
- **Scope of delivery:**
 - EMC front panel, incl. pressed-in centering pin and bushes M2.5
- EMC-gasket see below
- Front panel screw see below
- Handles and card holders cannot be fitted with this type of front panel



Width	Part-No. 3 U	Part-No. 6 U
4 HP	66-514-73	66-514-76
6 HP	66-516-73	66-516-76
8 HP	66-518-73	66-518-76

2.2.1.1 EMC Gasket (Stainless Steel)

Height	Part-No.
3 U	81-062-03
6 U	81-062-06

2.2.1.2 Front Panel Screws

- Front panel width up to 8 HP = 2 screws

Description	Part-No.
Torx screw, M2.5 x 11.3, size T8	5443-08
Rounded head screw, cross recessed M2.5 x 12.7	61-287

Use Elma's front panel service for machining and screen printing of your panels!

2: Front Panels for Plug-In Units

2.2.2 EMC Front Panels for IEC Plug-In Units with Cutout for Ejector Handle acc. to IEC

EMC Front Panels Aluminium with EMC Gasket

- Excellent EMC shielding
- Immune to snagging
- EMC-gasket slid onto the extrusion
- **Scope of delivery:**
 - EMC front panel, incl. pressed-in bushes M2.5 (size ≥ 10 HP)
- EMC-gasket see 2.2.2.4
- Handle has to be ordered separately, see 2.2.2.6
- Front panel screw (size ≥ 10 HP), see 2.2.2.5

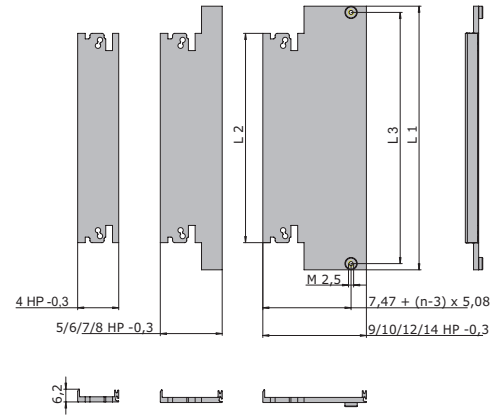

2.2.2.1 Front Anodised, Rear Conductive (2 cutouts)

- With 2 cutouts (bottom + top)

Width	Part-No. 3 U	Part-No. 6 U	Part-No. 9 U
4 HP	66-514-23	66-514-26	66-514-29
5 HP	66-515-23	66-515-26	-
6 HP	66-516-23	66-516-26	66-516-29
7 HP	66-517-23	66-517-26	-
8 HP	66-518-23	66-518-26	66-518-29
9 HP	66-519-23	66-519-26	-
10 HP	66-520-23	66-520-26	66-520-29
12 HP	66-522-23	66-522-26	-
14 HP	66-534-23	66-534-26	-

2.2.2.2 Front Anodised, Rear Conductive (1 cutout)

- With 1 cutout (bottom)
- Incl. pressed-in centring pin and bush M2.5 (top)
- Incl. cutout for mounting of card holder 61-156 (top) with screw 5322-08 (see 2.2.2.7)

Width	Part-No. 3 U
4 HP	66-514-43
5 HP	66-515-43
6 HP	66-516-43
8 HP	66-518-43
10 HP	66-520-43
12 HP	66-522-43
14 HP	66-534-43



Dimensions

Height	L1 mm	L1 inch	L2 mm	L2 inch	L3 mm	L3 inch
3 U	128.55	5.06	102.05	4.01	122.50	4.82
6 U	261.90	10.31	235.40	9.27	255.85	10.07
9 U	395.25	15.56	368.75	14.51	389.20	15.32

2: Front Panels for Plug-In Units

2.2.2.4 EMC-Gasket (Stainless Steel)

Unit	Part-No. 3 U	Part-No. 6 U	Part-No. 9 U
1 pc.	81-062-03	81-062-06	81-062-09

2.2.2.5 Front Panel Screw

- For EMC front panels size ≥ 9 HP = 2 additional screws are needed

Description	Part-No.
Cross recessed rounded head screws M2.5 x 12.7	61-287
Torx screws M2.5 x 11.3, size T8	5443-08

2.2.2.6 Ergonomic Ejector Handles acc. to IEC

- Simple assembly of plug-in units
- Allows trouble-free extraction of electronic units with multi-pole connectors
- Main features in one part: card holder, ejector handle and centring pin
- Reset spring for safe insertion
- One version for top and bottom only
- Handle is injection moulded, glass-reinforced plastic, UL94 V-0
- Card holder is zinc die-cast, nickel plated
- Reset spring is stainless steel
- Scope of delivery:**
 - Ejector handle
 - Assembly material (cross recessed screws M2.5 for fixing of card holder/printed board/front panel)
- Front panel with special cutouts have to be ordered separately

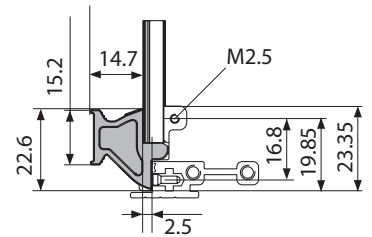

2.2.2.6 Ejector Handle acc. to IEC

Description	Part-No.
Ejector handle black	81-233
Ejector handle grey	81-234

Extraction process:

Rest position

Extraction

End position

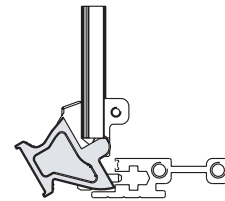
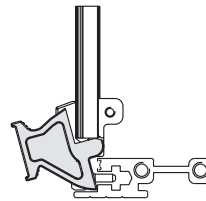
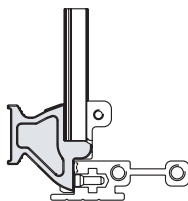

Label

Description	Part-No.
1 sheet A4 of 220 labels	81-031

2: Front Panels for Plug-In Units

2.2.2.7 Card Holder acc. to IEC Standard

- By using the zinc die-cast card holder, flat front panels and EMC front panels acc. to IEC can be connected to a PC card to form a plug-in unit
- The card can be mounted both in the standard position and offset 1 HP (5.08 mm)
- **Scope of delivery:**
 - Card holder
- Assembly material see below



2.2.2.7 Card Holder without Swivel Stop

Description	Application	D	Part-No.
Card holder without swivel stop	Without injector / ejector handle	M2.5	61-156

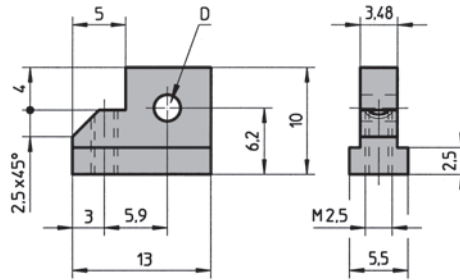

Assembly Material

Description	Application	Part-No.
Cross recessed countersunk screw M2.5 x 8	For card holder	5322-08
Torx countersunk screw M2.5 x 8, size T8	For card holder	5470-21
Slotted pan head screw M2.5 x 6	For printed board	5571-06
Torx cylinder head screw M2.5 x 6, size T8	For printed board	5470-04



2.2.2.8 Card Holder/End Piece without ESD Pin

- **Scope of delivery:**
 - End piece card holder (zinc die-cast, nickel plated)
 - Assembly material (screws M2.5 for fixing of front panel/card holder/printed board)

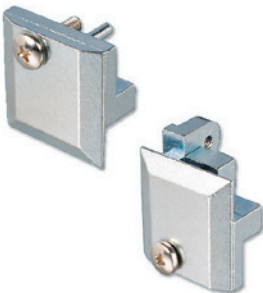

Card Holder/End Piece without ESD Pin

Description	Part-No.
Top	81-018-01
Bottom	81-019-01