

3: Handles

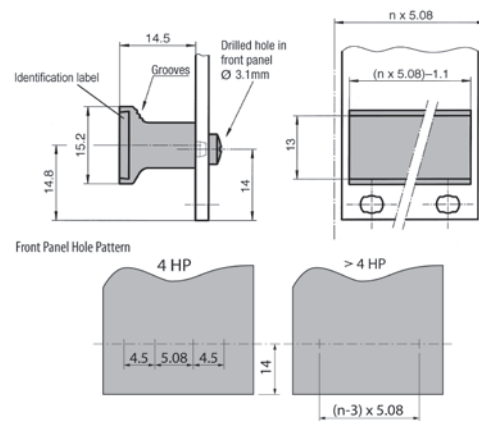

3.2 Rigid-Mounted Unit Handles

- Shape/finish and mounting position which correspond to those of the injector/ejector handles
- 4 HP to 12 HP injection-moulded in black glass reinforced Nylon (UL94 V-0)
- 14 HP to 84 HP are extruded in black Noryl (UL94 V-0)
- Aluminium identification labels are inserted into a slot in the handle
- Handles are fixed to the front panels using self-tapping, self-centering screws
- Handles for 4 HP have positioning nipples, allowing them to be fixed with one screw, without turning
- Width greater than 4 HP, at least two screws must be used for fixing
- Grooves on the handle always point towards the middle of the unit
- **Scope of delivery:**
 - Rigid-mounted handle
 - Identification label
- Assembly material see below



3.2 Rigid-Mounted Handle with Identification Label

Width	Scope of Delivery	Part-No.
4 HP	10 pcs.	60-200-04
5 HP	10 pcs.	60-200-05
6 HP	10 pcs.	60-200-06
7 HP	10 pcs.	60-200-07
8 HP	10 pcs.	60-200-08
10 HP	10 pcs.	60-200-10
12 HP	10 pcs.	60-200-12
14 HP	1 pc.	60-200-14

- Other sizes (up to 84 HP) are available upon request

Assembly Material

Description	Part-No.
Cross recessed rounded head screw	61-276