

3: EMC Sub Rack Magic-/Spirit-Kit 11

A



3.6.7.5 Injector/Ejector Handles acc. to IEEE

Type			Mounting	ESD Pin	Colour	Part-No 1 pc.	Part-No. 100 pcs.
Ergonomic			Bottom	With ESD-pin	Black	81-076	81-076-2
Ergonomic			Top	With ESD-pin	Black	81-075	81-075-2
Ergonomic			Bottom	Without ESD-pin	Black	81-076-01	81-076-01-2
Ergonomic			Top	Without ESD-pin	Black	81-075-01	81-075-01-2
Ergonomic	Hot Swap		Bottom	With ESD-pin	Black	81-096	81-096-2
Ergonomic	Hot Swap		Top	With ESD-pin	Black	81-095	81-095-2
Ergonomic	Hot Swap		Bottom	Without ESD-pin	Black	81-096-01	81-096-01-2
Ergonomic	Hot Swap		Top	Without ESD-pin	Black	81-095-01	81-095-01-2
Ergonomic	Hot Swap	Offset	Bottom	With ESD-pin	Black	81-185	81-185-2
Ergonomic	Hot Swap	Offset	Top	With ESD-pin	Black	81-184	81-184-2
Classic			Bottom	With ESD-pin	Black	81-261	81-261-2
Classic			Top	With ESD-pin	Black	81-260	81-260-2
Classic		Offset	Bottom	With ESD-pin	Black	81-161	81-161-2
Classic		Offset	Top	With ESD-pin	Black	81-160	81-160-2
Classic	Hot Swap		Bottom	With ESD-pin	Black	81-256	81-256-2
Classic	Hot Swap		Top	With ESD-pin	Black	81-255	81-255-2
Classic	Hot Swap	Offset	Bottom	With ESD-pin	Black	81-156	81-156-2
Classic	Hot Swap	Offset	Top	With ESD-pin	Black	81-155	81-155-2
Telecom	Hot Swap		Bottom	With ESD-pin	Black	81-206	81-206-2
Telecom	Hot Swap		Top	With ESD-pin	Black	81-205	81-205-2
Telecom	Hot Swap		Bottom	Without ESD-pin	Black	81-206-01	81-206-01-2
Telecom	Hot Swap		Top	Without ESD-pin	Black	81-205-01	81-205-01-2
Telecom	Hot Swap	Offset	Bottom	With ESD-pin	Black	81-189	81-189-2
Telecom	Hot Swap	Offset	Top	With ESD-pin	Black	81-188	81-188-2
Telecom long	Hot Swap		Bottom	With ESD-pin	Black	81-215	81-215-2
Telecom long	Hot Swap		Top	With ESD-pin	Black	81-214	81-214-2
Telecom long	Hot Swap	Offset	Bottom	With ESD-pin	Black	81-116	81-116-2
Telecom long	Hot Swap	Offset	Top	With ESD-pin	Black	81-117	81-117-2
Microswitch						81-088-1 (10 pcs.)	81-088-2

For more information refer to chapter C | 3 "Handles".

3: EMC Sub Rack Magic-/Spirit-Kit 11

3.6.7.6 Card Holder and Coding Pins acc. to IEEE

- **Scope of delivery:**
 - End piece card holder (zinc die-cast, nickel plated)
 - Assembly material
(screws M2.5 for fixing of front panel/card holder/printed board)



Card Holder/End Piece *with* ESD Pin

Description	Part-No. 1 pc.	Part-No. 100 pcs.
Top	81-018	81-018-2
Bottom	81-019	81-019-2



Card Holder/End Piece *without* ESD Pin

Description	Part-No. 1 pc.	Part-No. 100 pcs.
Top	81-018-01	81-018-01-2
Bottom	81-019-01	81-019-01-2



Middle Part

- Usable for all front panels
- For positioning and fixing of 6 U and 9 U cards, card thickness 1.6 mm
- Material: Plastic UL94 V-0

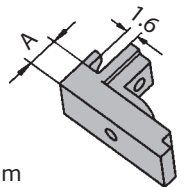

Description	A		Part-No. 10 pcs.	Part-No. 100 pcs.
	mm	inch		
Aluminium 2.5 mm	2.5	0.10	61-960-1	61-960-2
Stainless steel	4.5	0.18	61-963-1	61-963-2

Assembly Material

Description	Part-No. 100 pcs.
100 screws (PT-countersunk, 2.5 x 6)	5534-06-2



Coding Pins

- Acc. to IEC 60297-3-103
- Plastic, UL94 V-0
- Can be rotated in 4 positions

Description	Part-No. 1 pc.	Part-No. 100 pcs.
Grey	81-054-02	81-054-02-2
Dark red	81-054-06	81-054-06-2
Black	81-054-04	81-054-04-2

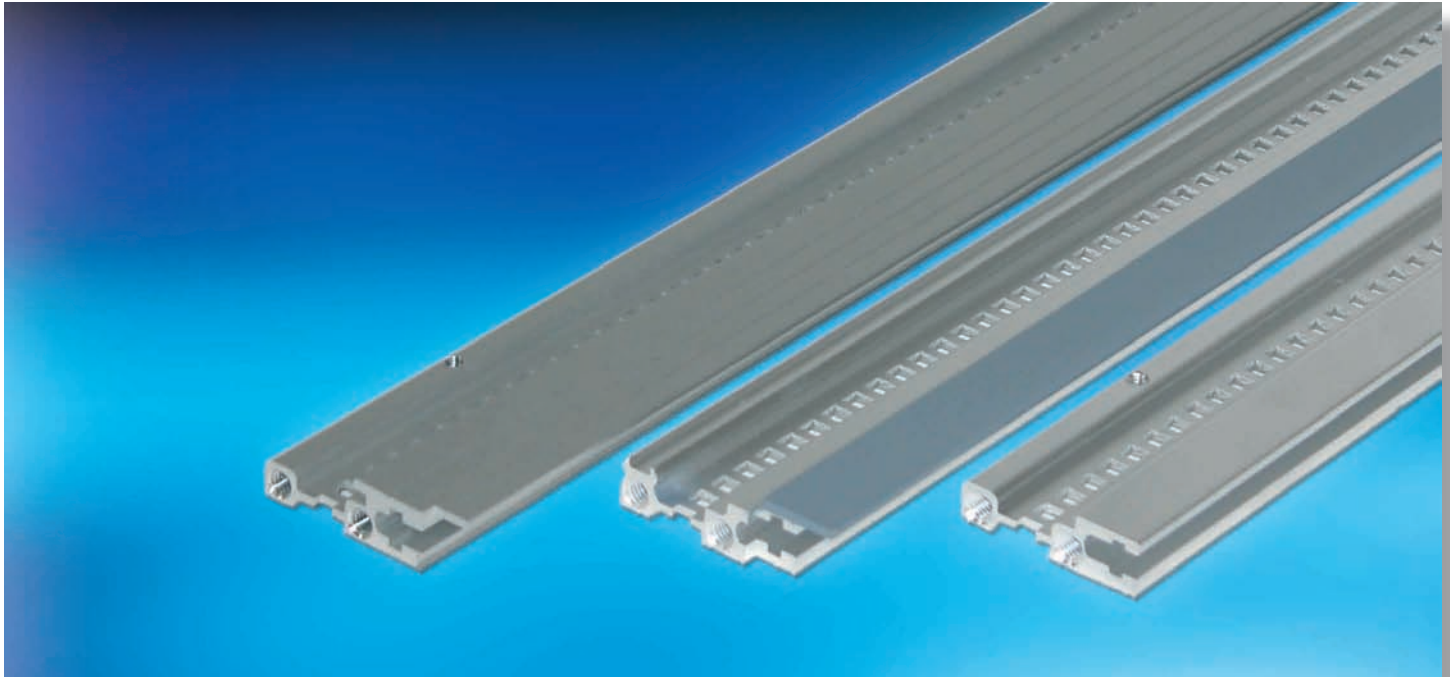

3.7 Extrusions

3.7.1 Front Extrusions

3.7.1.1 Front Extrusion 66-665

- For Magic-Kit 11 according to IEC/EN standard
- Accept 2 x 6 mm tapped strips
- **Scope of delivery:**
 - 1 front extrusion without assembly material

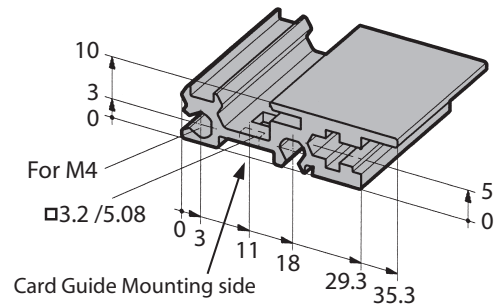

3.7.1.1 Standard Version

Length for HP	Length		Part-No. clear passivated
	mm	inch	
84	431.8	17.00	66-665-53

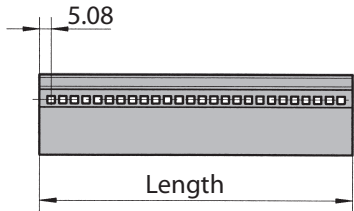

3.7.1.2 Front Extrusion 66-666

- For Spirit-Kit 11 according to IEEE standard
- Accept 2 x 6 mm tapped strips
- **Scope of delivery:**
 - 1 front extrusion without assembly material

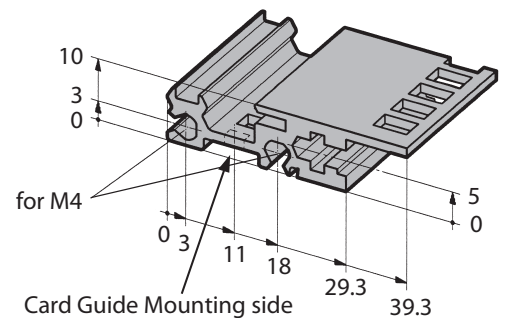

3.7.1.2 Standard Version

Length for HP	Length		Part-No. clear passivated
	mm	inch	
84	431.8	17.00	66-666-53

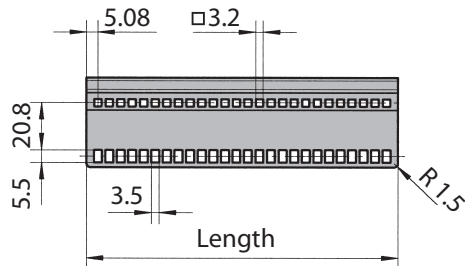

3: EMC Sub Rack Magic-/Spirit-Kit 11

3.7.1.3 Front Extrusion 66-111, IEC

- For sub racks and cases front
- Accept 2 x 6 mm tapped strips
- **Scope of delivery:**
 - 1 front extrusion without assembly material

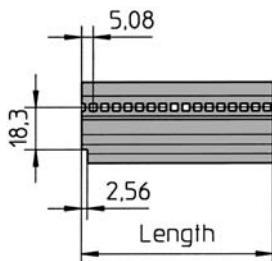
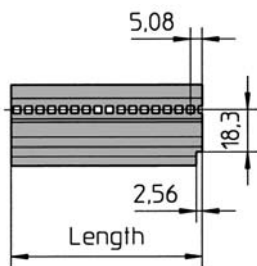
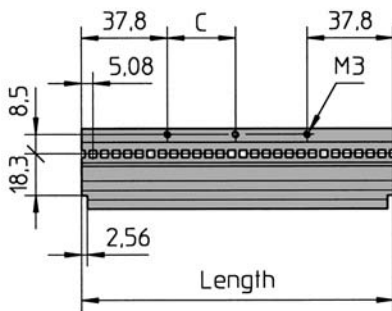
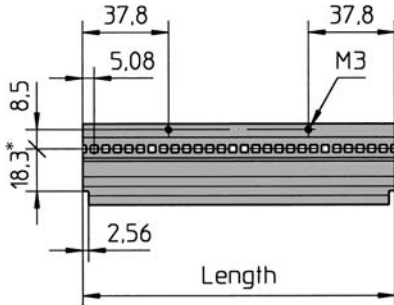
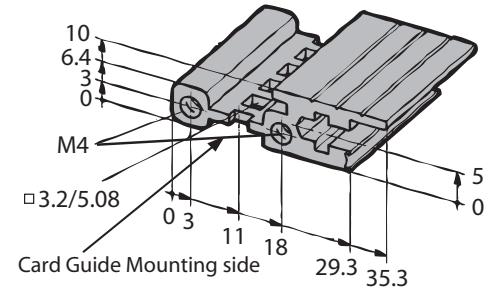

Standard Version

Length for HP	Length		Part-No.			
	mm	inch	clear anodised	black anodised	clear passivated	raw
21	111.8	4.40	66-111-26	-	-	-
28	147.3	5.80	66-111-25	-	-	-
32	167.6	6.80	66-111-62	-	66-111-162	-
42	218.4	8.60	66-111-60	-	66-111-75	-
63	325.1	12.80	66-111-61	-	66-111-76	-
81	416.6	16.40	66-111-22	-	66-111-77	-
84	431.8	17.00	66-111-23	66-111-56	66-111-78	-
	1350.0	53.15	-	-	-	66-111-19

EMC Version

Length for HP	Length		Holes	Part-No.
	mm	inch	n x C	clear passivated
42	218.4	8.60	2 x 71.42	66-111-50
63	325.1	12.80	3 x 83.17	66-111-51
81	416.6	16.40	4 x 85.24	66-111-52
84	431.8	17.00	4 x 89.05	66-111-53

Height Divider Right

Length for HP	Length		Part-No.
	mm	inch	anodised
4.5	22.86	0.90	66-111-70
8.5	43.18	1.70	66-111-71
12.5	63.50	2.50	66-111-72
16.5	83.82	3.30	66-111-73

Height Divider Left

Length for HP	Length		Part-No.
	mm	inch	anodised
4.5	22.86	0.90	66-111-80
8.5	43.18	1.70	66-111-81
12.5	63.50	2.50	66-111-82
16.5	83.82	3.30	66-111-83

3: EMC Sub Rack Magic-/Spirit-Kit 11

3.7.2 Internal Extrusions

3.7.2.1 Internal Extrusion 66-193 for use of Insulating Strip

- For mounting backplanes in sub racks
- insulating strip see 3.7.2.5
- **Scope of delivery:**
 - 1 extrusion without assembly material

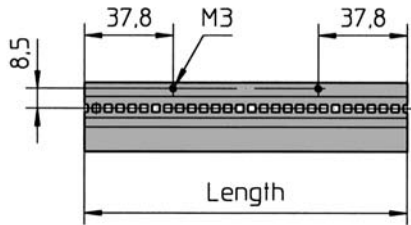
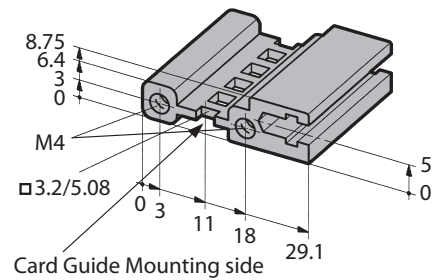

Standard Version

Length for HP	mm	inch	Part-No.	
			clear passivated	raw
32	167.6	6.60	66-193-26	
42	218.4	8.60	66-193-20	
63	325.1	12.80	66-193-21	
81	416.6	16.40	66-193-22	
84	431.8	17.00	66-193-23	
	1350.0	53.14		66-193-19

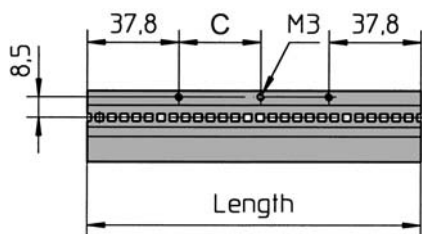

EMC Version

Length for HP	mm	inch	Part-No. clear passivated
84	431.8	17.00	66-193-63

3.7.2.2 Internal Extrusion 66-194 without use of Insulating Strip

- For mounting backplanes without an insulating strip
- **Scope of delivery:**
 - 1 extrusion without assembly material

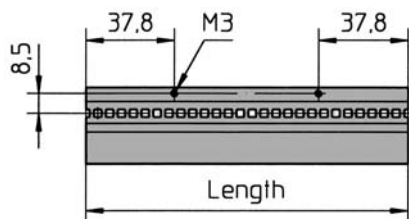
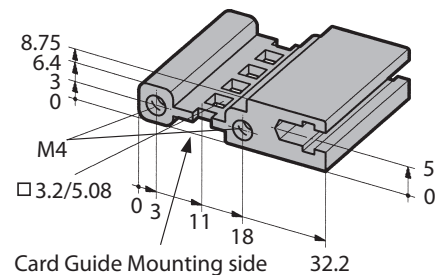

Standard Version

Length for HP	mm	inch	Part-No.	
			clear passivated	raw
84	431.8	17.00	66-194-23	
	1350.0	53.14		66-194-19

3: EMC Sub Rack Magic-/Spirit-Kit 11

A

3.7.2.3 Double Extrusion 66-192 for use of Insulating Strip

- For mounting backplanes, matches 66-193, 66-288
- For use with insulating strips
- Insulating strip see 3.7.2.5
- **Scope of delivery:**
 - 1 extrusion without assembly material

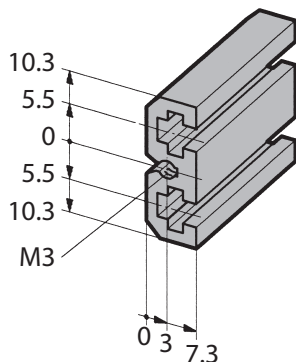

Length for HP	mm		Part-No.	
	mm	inch	clear passivated	raw
84	431.8	17.00	66-192-24	
	1350.0	53.14		66-192-14

Length for HP	mm	inch	Part-No. clear passivated
42	213.4	8.40	66-192-20
63	320.0	12.59	66-192-21
81	411.5	16.20	66-192-22
84	426.7	16.79	66-192-23

Assembly material with adapter: 63-175

3.7.2.4 Double Extrusion 66-195 without use of Insulating Strip

- For mounting backplanes without insulating strips
- Matches 66-194, 66-289, 66-290
- **Scope of delivery:**
 - 1 extrusion without assembly material

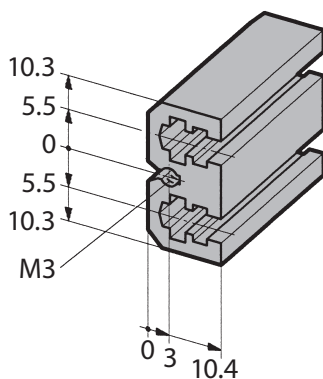

Length for HP	mm	inch	Part-No. clear passivated
84	431.8	17.00	66-195-24

Length for HP	mm	inch	Part-No. clear passivated
81	411.5	16.20	66-195-22
84	426.7	16.77	66-195-23

Assembly material with adapter: 63-175

3: EMC Sub Rack Magic-/Spirit-Kit 11

3.7.2.5 Insulating Strip 66-901

- Plastic grey
- Use with extrusions 66-112, 66-192, 66-193, 66-288

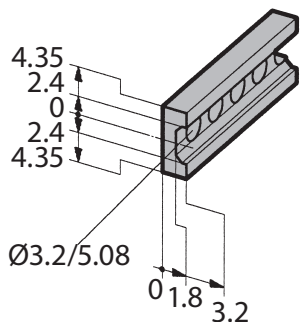

Length for HP	Length		Part-No.
	mm	inch	
42	216.44	8.52	66-901-20
63	323.12	12.72	66-901-21
81	414.56	16.32	66-901-22
84	429.80	16.92	66-901-23

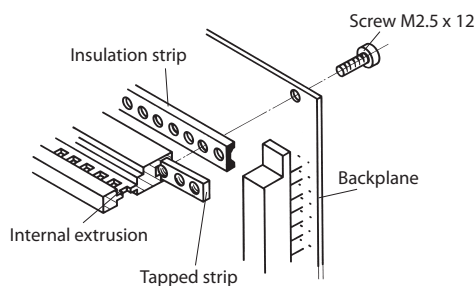

Mounting with Insulation Strips

Description	Part-No. 1 pc.	Part-No. 100 pcs.
Cross recessed cylinderhead earthing screw M2.5 x 12	5325-12	1910-07

3.7.2.6 Edge Connector Extrusion 66-147

- Supplementary edge connector extrusion for IEC 60603-2
- Matches 66-112, 66-192, 66-193
- **Scope of delivery:**
 - 1 extrusion without assembly material

