

3: EMC Sub Rack Magic-/Spirit-Kit 11

A

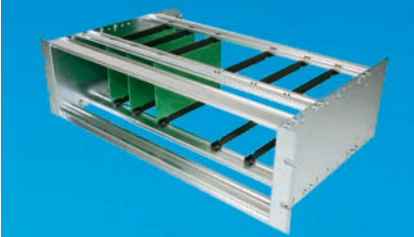
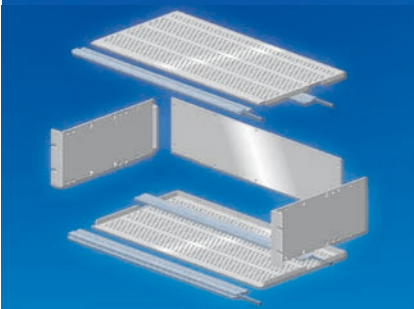
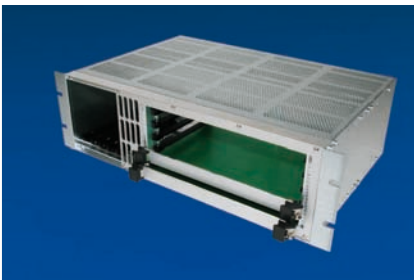

3.1 Magic- /Spirit-Kit 11 Overview

A | 3_3

3.2 Basic Case

A | 3_7

3.2.1 Magic-Kit 11 (IEC 60297)

A | 3_7

3.2.2 Spirit-Kit 11 (IEEE 1101.10 and CompactPCI)

A | 3_7

3.2.3 Rear Panel

A | 3_7

3.2.4 Line Drawings

A | 3_8

3.3 Adaptation Kit

A | 3_9

3.3.1 Adaptation Kit

A | 3_9

3.3.2 Edge Connector Extrusion 66-147

A | 3_9

3.4 Assembly Accessories

A | 3_10

3.4.1 Front Sub Division Vertical

for 6 U System or 6 U Assembly

A | 3_10

3.4.2 EMC Front Sub Division Vertical Small

A | 3_11

3.4.3 Horizontal Card Mounting Kit for Double Eurocards (6 U) A | 3_11

3.4.4 Fan Front Panels for Horizontal Mounting Kits

A | 3_12

3.4.5 Mounting Chassis

A | 3_13

3.4.6 EMC Contact Strips (Advanced EMC-level)

A | 3_13

3.4.7 Earthing Set

A | 3_14



3.5 General Accessories A | 3_15

3.5.1 Card Guides IEC A | 3_15

3.5.2 Card Guides acc. to IEEE A | 3_17

3.6 Front Panels A | 3_20

3.6.1 Flat Front Panels A | 3_20

3.6.2 EMC Flat Front Panels A | 3_21

3.6.3 Fan Front Panels A | 3_24

3.6.4 Hinged Front Panels A | 3_26

3.6.5 Plug-In Units acc. to IEC A | 3_28

3.6.6 EMC Plug-In Units acc. to IEC A | 3_31

3.6.7 Plug-In Units acc. to IEEE A | 3_35

3.7 Extrusions A | 3_39

3.7.1 Front Extrusions A | 3_39

3.7.2 Internal Extrusions A | 3_41



3.1 Magic- /Spirit-Kit 11 Overview

Technical features

- Advanced EMC shielding without gaskets is standard
- Internal adaption parts freely accessible
- Rapid assembly
- Easy access for maintenance
- Sheet steel, pre-galvanized
- Vibration-proof
- Dimensions and adaptations according to IEC 60297
- Suitable for IEC 60297 or IEEE 1101.10

Scope of delivery

- Numerous accessories
- Vertical and horizontal card mounting

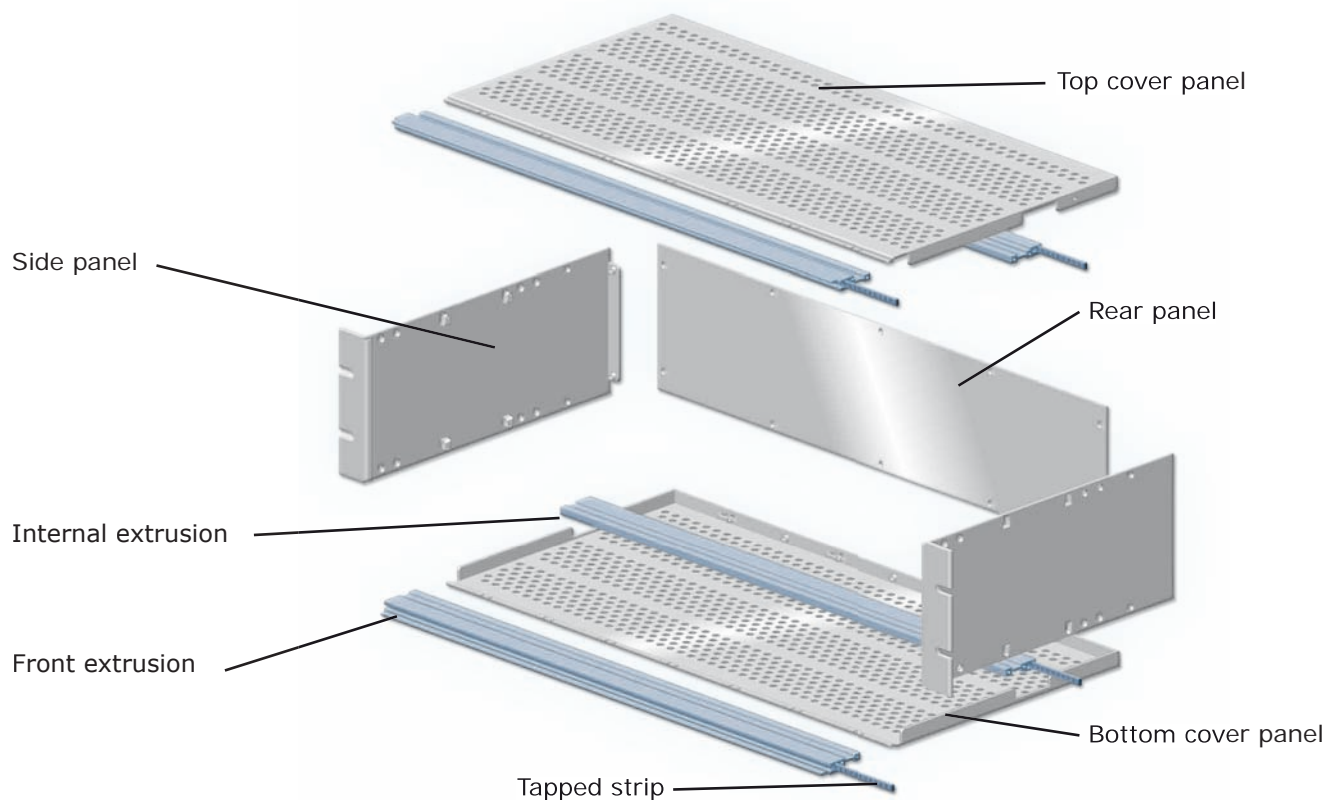

3: EMC Sub Rack Magic-/Spirit-Kit 11

Magic-Kit 11

Front extrusions according to IEC 60297 specifications.

Spirit-Kit 11

Front extrusions according to IEEE 1101.10 and CompactPCI specifications, specially designed for plug-in units with high insert / extract forces.



Width	84 HP	
Height	Magic-Kit 11	Spirit-Kit 11
3 U		
6 U		

Depth 240 mm 300 mm 390 mm
 9.44" 11.81" 15.35"

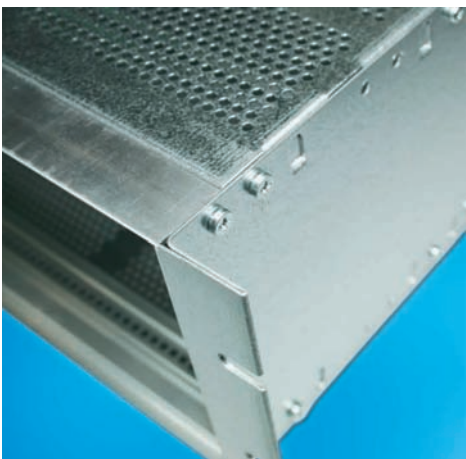

The cost-optimised solution

- by integrated 19"-lugs
- by use of sheet steel, pre-galvanised
- by integrated EMC contacts
- by fast assembly

3: EMC Sub Rack Magic-/Spirit-Kit 11

EMC

"Electromagnetic compatibility is the ability of a system to operate in the intended environment without causing or suffering unacceptable degradation of performance due to unintentional electromagnetic radiation or response."

The EMC characteristics of a system therefore consist of an appropriate immunity from interference (noise immunity) and a limited emission of interference (noise emission).

Elma's EMC concept describes three levels of electromagnetic shielding performance (Performance Level). The attenuation levels will simplify the selection of sub racks for the user.

Test setup: The first measurement E1 is without the enclosure. The next measurement E2 is made with the transmitting antenna installed inside the enclosure. The difference between the received signal without and with the enclosure represents the shielding effectiveness in dB.

Performance Level	30 - 230 MHz	230 - 1000 MHz	1000 - 2000 MHz
1 / Elma: Basic level	20 dB	10 dB	0 dB
2 / Elma: Advanced level	40 dB	30 dB	20 dB
3 / Elma: Superior level	60 dB	50 dB	40 dB

The standard configuration will provide you with an advanced EMC level. If you require a superior EMC level for your system, you need to talk to an engineer.

Typical shielding effectiveness for Magic-/Spirit-Kit 11

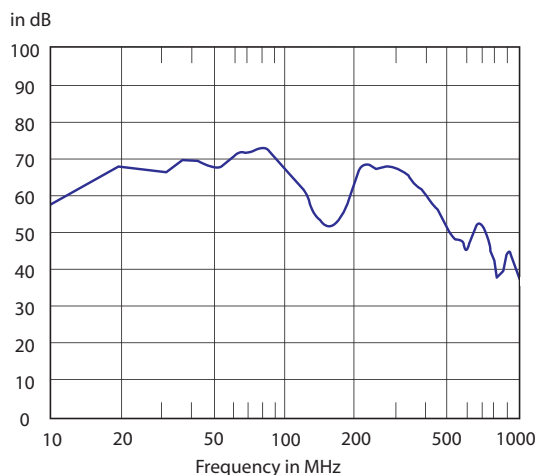









By means of standard snap-fit and screw connections suitable for demanding applications.



3: EMC Sub Rack Magic-/Spirit-Kit 11

Economical 5-minute assembly

A

	1 min 	Open the package and lay out the parts...
	4 min 	...screw together the two side panels, four extrusions and four tapped strips - and the frame is ready.
	4.5 min 	Insert top and bottom cover, tighten four screws...
	5 min 	 ...and your EMC sub rack is fully assembled - without additional gaskets.



3.2 Basic Case

- Advanced EMC shielding is standard
- Dimensions according to IEC 60297
- Rapid assembly
- Top and bottom covers fully perforated
- Aluminium extrusions, electrically conductive
- Side plates, top and bottom covers of pre-galvanized sheet steel
- **Scope of delivery:**
 - 2 side panels
 - 2 front extrusions
 - 2 internal extrusions
 - 4 tapped strips (6 pcs. for 6 U Version)
 - 2 insulating strips (for backplane, insulated mounting only); 4 pcs. for 6 U Version
 - 2 top / bottom covers, perforated
 - Assembly material
 - EMC-gasket for front / side
 - 1 double extrusion (6 U Version only)
- Rear panel has to be ordererd separately



3.2.1 Magic-Kit 11 (IEC 60297)

Height U	Width HP	Backplane Mounting	Depth		
			240 mm/9.44"	300 mm/11.81"	390mm/ 15.35"
3 U	84	Insulated	11A131-6	11A132-6	11A133-6
3 U	84	Conductive	11A131-7	11A132-7	11A133-7
6 U	84	Insulated	11A161-6	11A162-6	11A163-6
6 U	84	Conductive	11A161-7	11A162-7	11A163-7

3.2.2 Spirit-Kit 11 (IEEE 1101.10 and CompactPCI)

Height U	Width HP	Backplane Mounting	Depth		
			240 mm/9.44"	300 mm/11.81"	390mm/ 15.35"
3 U	84	Insulated	11B131-6	11B132-6	11B133-6
3 U	84	Conductive	11B131-7	11B132-7	11B133-7
6 U	84	Insulated	11B161-6	11B162-6	11B163-6
6 U	84	Conductive	11B161-7	11B162-7	11B163-7

3.2.3 Rear Panel

- Galvanized sheet steel
- **Scope of delivery:**
 - 1 rear panel
- Assembly material included in case

Height	Description	Part-No.
3 U	Rear panel	22-384
6 U	Rear panel	22-684

3: EMC Sub Rack Magic-/Spirit-Kit 11

3.2.4 Line Drawings

Front view

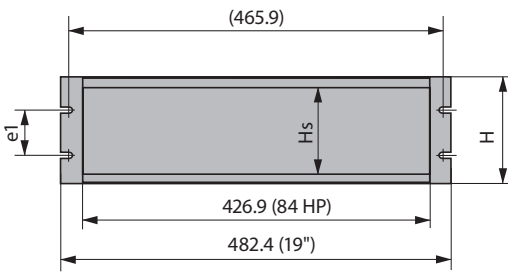

Side view

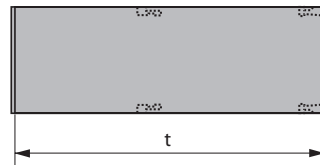

Top view

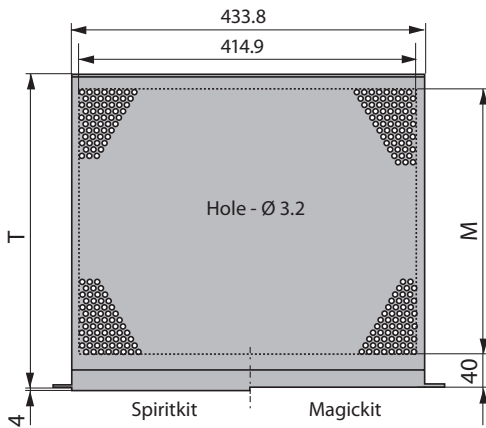

Heights

for	H		Hs		e1	
	mm	inch	mm	inch	mm	inch
3 U	132.50	5.21	112.50	4.42	57.20	2.25
6 U	265.85	10.46	245.85	9.67	190.55	7.50

Depths

T		t	
mm	inch	mm	inch
240	9.44	232.6	9.15
300	11.81	292.6	11.51
390	15.35	382.6	15.06

Air flow

Depth		M		Air flow	
mm	inch	mm	inch	mm ²	sq. inch
240	9.44	186.8	7.35	28953	44.87
300	11.81	244.0	9.60	37638	58.33
390	15.35	333.2	13.11	52115	80.77

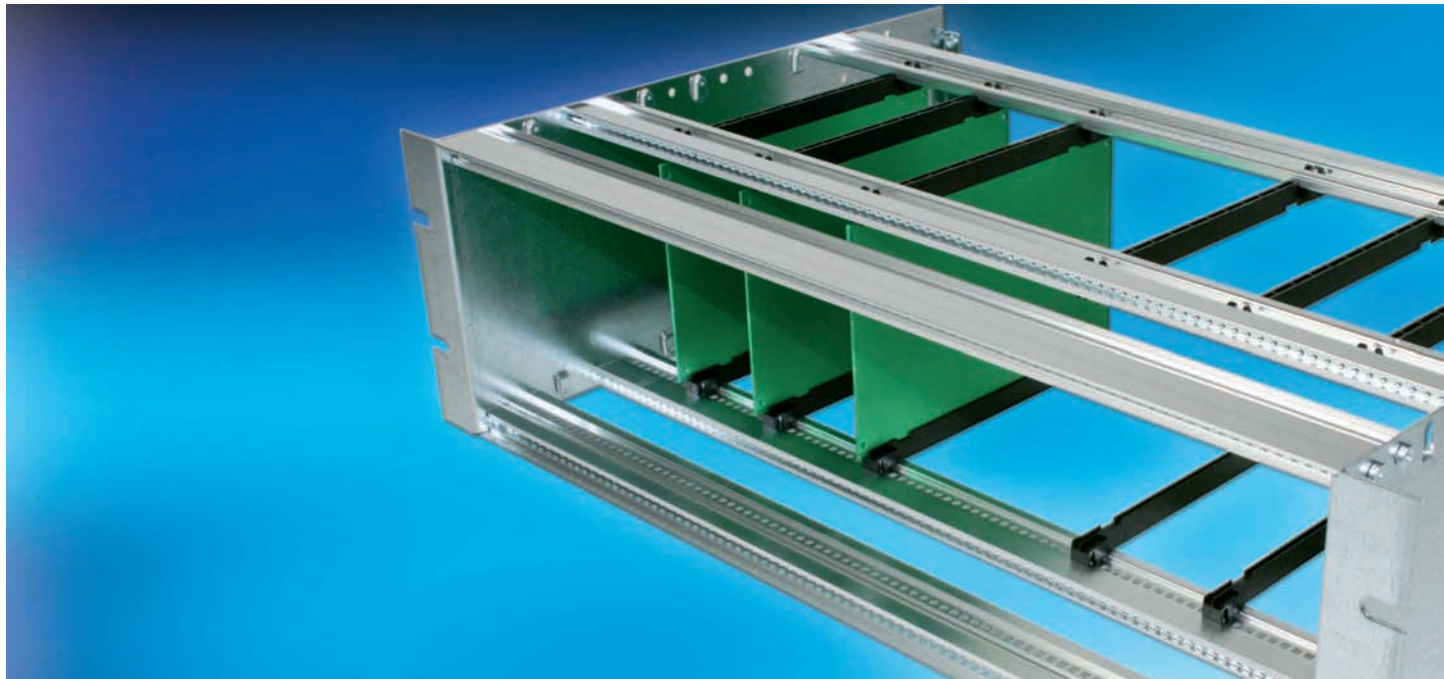

3.3 Adaptation Kit

3.3.1 Adaptation Kit

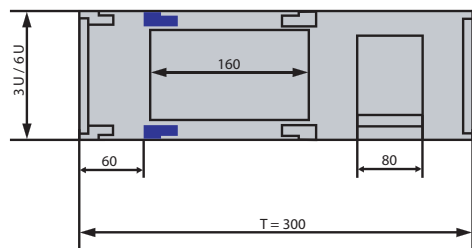

3.3.1 Adaptation Kit

- **Range of Application:**
 - Recessed mounting of single / double eurocards, depth 160 – 220 mm
 - Without individual front panels
- **Scope of delivery:**
 - 2 internal extrusions
 - 2 tapped strips
 - 1 set assembly material

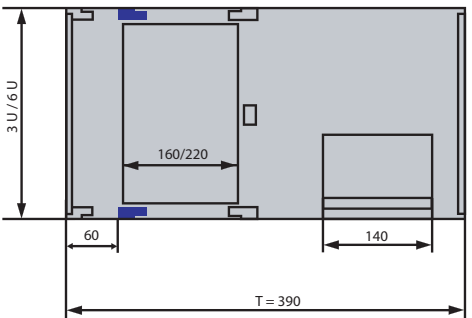

Description	84 HP
Recessed mounting of single / double eurocards without front panels	11-530

3.3.2 Edge Connector Extrusion 66-147

- For use with extrusions for backplanes 66-193
- **Scope of delivery:**
 - 1 aluminium extrusion, clear passivated (conductive)

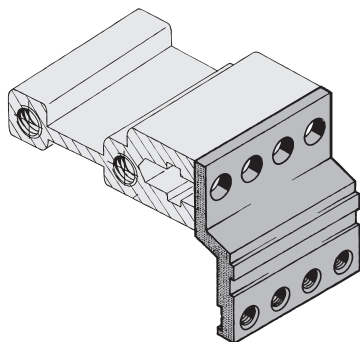

3.3.6 Edge Connector Extrusion

Description	8 HP	18 HP	28 HP	42 HP	63 HP	84 HP
For edge connector, IEC 60603-2	66-147-40	66-147-41	66-147-42	66-147-63	66-147-65	66-147-52

Assembly Material

Description	Part-No.
Assembly material M2.5 (for 2 supplementary extrusions)	63-214

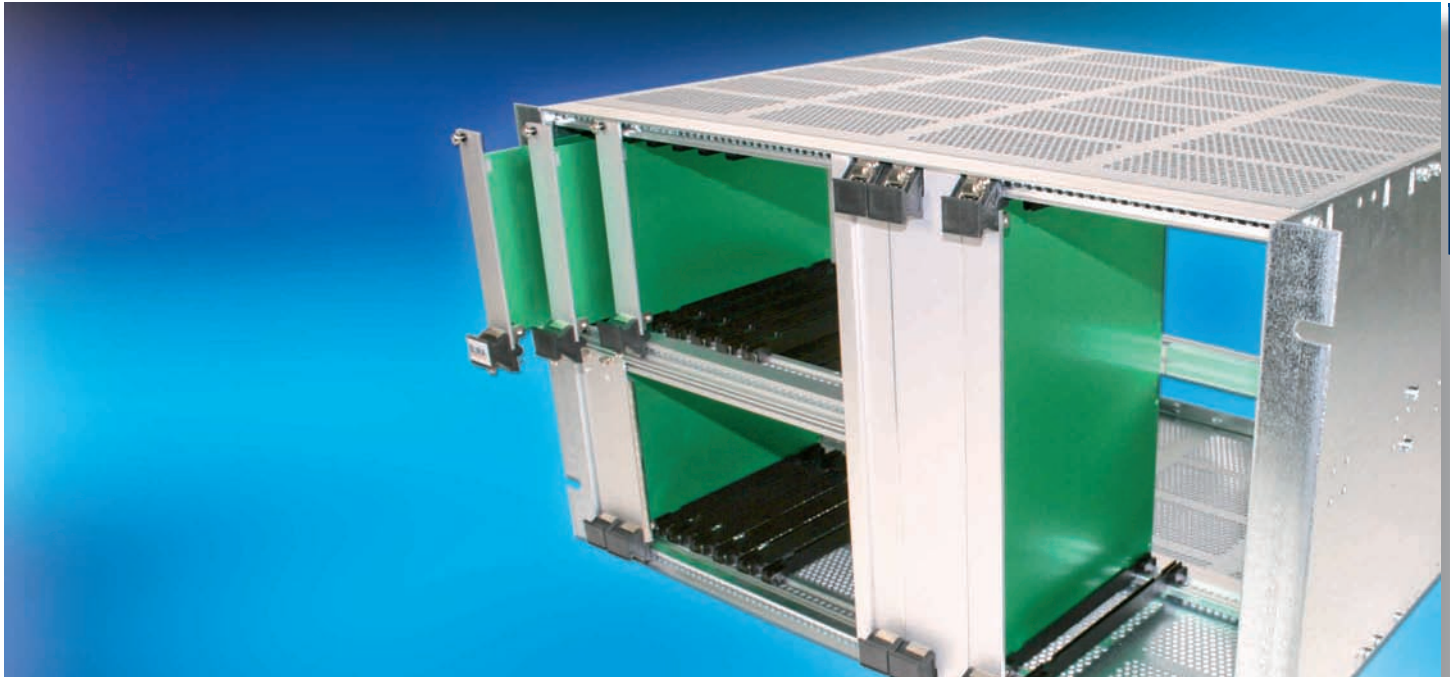

3.4 Assembly Accessories

3.4.1 Front Sub Division Vertical for 6 U System or 6 U Assembly

- Allows both single and double eurocards to be mounted together in a 6 U Magic-/Sprit-Kit 11
- **Scope of delivery:**
 - 1 divider extrusion front
 - 1 divider extrusion rear
 - 2 front extrusions
 - 2 internal extrusions
 - 1 assembly material
- Tapped strips for front extrusion see below
- Card guides see 3.5.1

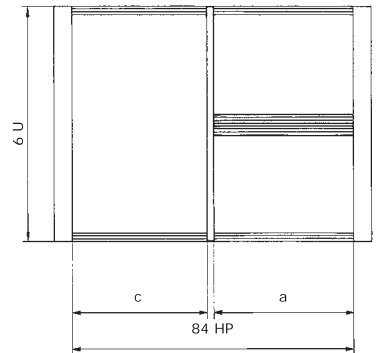

3.4.1 Front Sub Division Vertical for 6 U Assembly

Nominal Width		Part-No.
6 U (c)	2 x 3 U (a)	IEC 60297
50 HP	32 HP	11-959-2
40 HP	42 HP	11-949-2
19 HP	63 HP	11-939-2

Tapped Strips for Front Extrusion

Scope of Delivery	Description	Part-No.
1 pc. tapped strip	M2,5 32 HP = 162.56 mm	61-463
10 pcs. tapped strips		63-190
1 pc. tapped strip	M2,5 42 HP = 213.36 mm	61-464
10 pcs. tapped strips		63-057

3: EMC Sub Rack Magic-/Spirit-Kit 11

3.4.2 EMC Front Sub Division Vertical Small

- For dividing 6 U-systems
- Direct mounting onto the side panel
- For width of 4 HP and 8 HP
- Other sizes available upon request
- **Scope of delivery:**
 - 2 divider extrusions front
 - 2 divider extrusions rear
 - 2 tapped strips M2.5
 - 8 round head screws M4 x 10 recessed, Torx
 - 4 slotted countersunk screws M4 x 10 recessed, Torx
 - 2 set screws for fixing of tapped strips M2.5 x 8
 - 2 card guides 160mm (4 pcs. for 8 HP version)

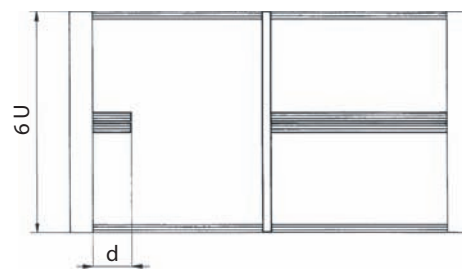

3.4.2 EMC Front Sub Division Vertical Small

Description	Part-No. d = 4 HP	Part-No. d = 8 HP
Front sub division vertical small IEEE	80-504-11	80-508-11
Front sub division vertical small IEC	80-204-11	80-208-11

3.4.3 Horizontal Card Mounting Kit for Double Eurocards (6 U)

- For double eurocards (6 U)
- Independent of card depth
- **Scope of delivery:**
 - 4 distance plates (2 front / 2 rear)
 - 4 length extrusions (2 front / 2 rear)
 - 1 centre extrusion
 - 6 tapped strips M2.5
 - 1 set assembly material
- Top and bottom cover plate when no overall fan front panel (3.4.4) is used
- Top and bottom cover plate has to be ordered separately
- Fan front panels for horizontal mounting kits see 3.4.4
- Card guides see 3.5.1
- Extruded front panels see 3.6.5

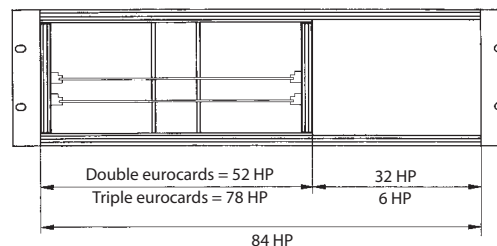

3.4.3 Horizontal Card Mounting Kit

Mounting height	Usable height	IEC 60603-2	Backplane	Cover plate top*	Cover plate bottom*
3 U	20 HP	14-971-30	14-971-60	21N602-90	21N602-90
6 U	48 HP	-	14-991-60	21N606-90	21N607-90

* Assembly material for cover plate see below

3.4.3.1 Front Panel Screws

- For cover panel
- Set of 10 screws
- With screw retainer

Description	Part-No. 10 pcs.
Torx screws M2.5 x 11.3 , size T8, with plastic screw retainer	63K159
Milled edge screws recessed M2.5 x 11.3, with plastic screw retainer	63-159

3: EMC Sub Rack Magic-/Spirit-Kit 11

3.4.4 Fan Front Panels for Horizontal Mounting Kits

- For horizontal mounting of double eurocards
- Aluminium 2.5 mm, clear anodised (non-conductive)
- **Scope of delivery:**
 - 1 perforated fan front panel
- Front panel screw see below
- On-off switch see below

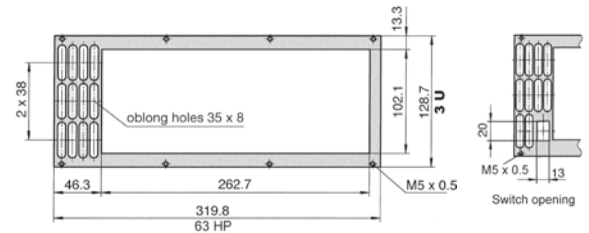

3.4.4 Fan Front Panels for Horizontal Mounting Kits

Description	Height	Width	Air passage		Part-No.
			mm ²	sq. inch	
Without switch opening	3 U	63 HP	3195	4.95	21N363-07
With switch opening	3 U	63 HP	2662	4.12	21N363-02



3.4.4.1 Front Panel Screws

- Set of 10 screws
- With threaded or press-fit bush
- 8 screws are necessary per front panel



Description	Part-No.
	10 pcs.
Recessed round head screw M2.5 x 11 with threaded bush M5 x 0.5	63-129
Recessed round head screw M2.5 x 11 with press-fit bush Ø3.7	63-444

3.4.4.2 On-Off Switch

- Black body, plastic
- 2 pole (only on-off switches)
- 250V, 16A
- Quick-connect terminal 6.3 x 0.8 mm
- Cut-out for 69-410-05: 13 x 20 mm (0.51" x 0.78")



Description	Part-No.
On-off switch, indicator light green (for fan front panel 3 U)	69-410-05

3: EMC Sub Rack Magic-/Spirit-Kit 11

3.4.5 Mounting Chassis

- For mounting non-standard modules and components
- Mounting chassis is fixed directly to the side panel
- **Scope of delivery:**
 - 1 mounting chassis
 - 1 set of assembly material (4 earthing nuts, 4 screws M4 x 6)

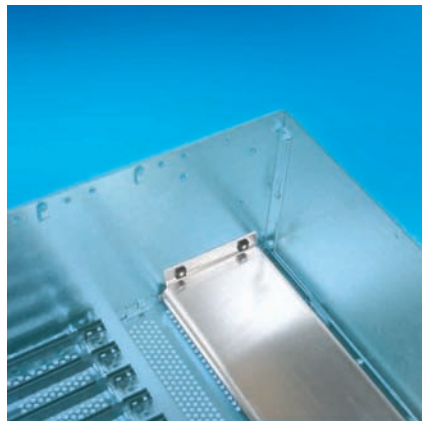

3.4.5.2 For Mounting of Power Supplies, etc.

Chassis depth 80 mm

Frame Width	A		D		Part-No.
	mm	inch	mm	inch	
84 HP	431.5	16.98	2	0.08	14-832-50

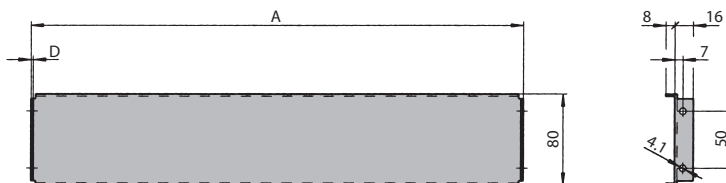

Chassis depth 140 mm

Frame Width	A		D		Part-No.
	mm	inch	mm	inch	
84 HP	431.5	16.98	2.0	0.08	14-836-50

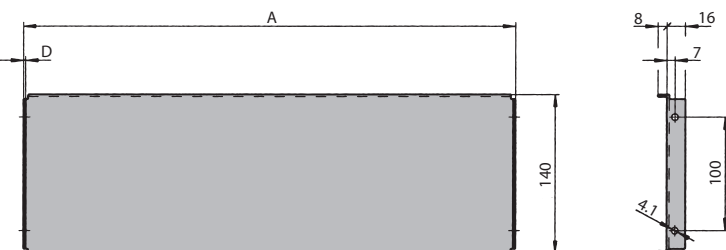

3.4.6 EMC Contact Strips (Advanced EMC-level)

- 2 contact strips
- For front panels, fixing on extrusion
- Self-adhesive



For HP	Length	Part-No.
84	424.2 mm	63-836-70

3.4.7 Earthing Set

- Enables cases to be earthed in conformance with EN / VDE / SEV
- **Scope of delivery:**
 - 1 press-in threaded bolt M4
 - 2 serrated lock washers
 - 2 hexagonal nuts M4
 - 1 terminal clamp
 - 1 earthing symbol

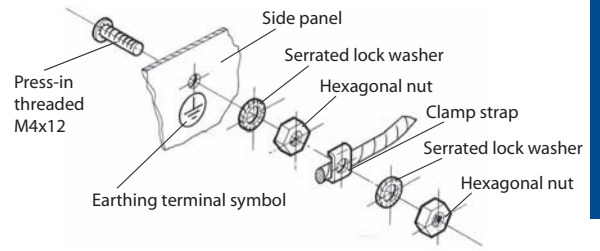

3.4.9 Earthing Set

Description	Part-No.
Earthing set according to EN VDE / SEV	63-174

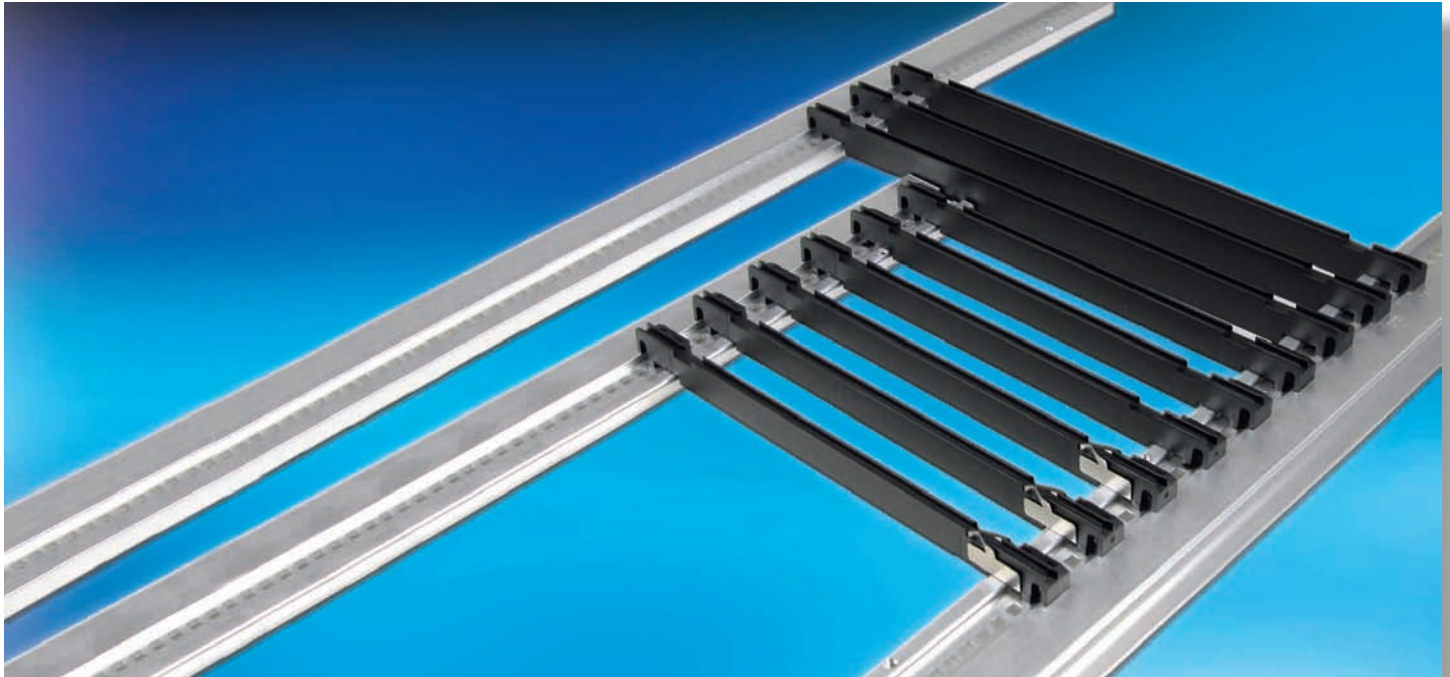

3.5 General Accessories

3.5.1 Card Guides IEC

- For positive location of PCBs and plug-in units conforming to the dimensions of card depths of 80 mm, 160 mm, 220 mm and 280 mm
- The card guides are non-flammable, made from a high-quality plastic material reinforced with fibreglass UL94 V-0
- Including ESD provisions

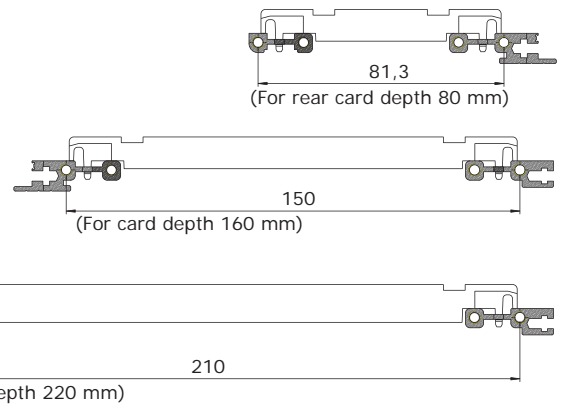

3.5.1.1 Card Guides 1-Slot

- **Scope of delivery:**
 - Card guide black plastic UL94 V-0
 - ESD Clip see below (not usable for card depth 80 mm)

Card Thickness		Card Depth		Part-No.	Part-No.	Part-No.
mm	inch	mm	inch	10 pcs.	100 pcs.	1000 pcs.
1.6	0.06	80	3.15	63-319	63-322	—
		160	6.30	63-028	63-029	63-478
		220	8.66	63-103	63-104	63-479
		280	11.02	63-323	63-324	61-017-3
2.0	0.08	160	6.30	63-328	63-329	—
		220	8.66	63-303	63-304	—
		280	11.02	63-445	63-446	—

ESD Clips

- Connecting printed board with case

Description	Part-No.	Part-No.
	10 pcs.	100 pcs.
ESD clip front bottom/rear top	63-863	63-864
ESD clip front top/rear bottom	63-865	63-866





3.5.1.2 Card Guides 7-Slot in 4 HP Steps

- For reduced assembly time of multiple slot applications
- For use with single, double and triple eurocards with a depth of 160 mm
- For card thickness: 1.6 mm / 0.06"
- Black plastic, UL94 V-0
- ESD Clip not usable

Card Thickness		Card Depth		Part-No. 1 pc.	Part-No. 50 pcs.
mm	inch	mm	inch		
1.6	0.06	160	6.30	61-076	63-364



3.5.1.3 Aluminium Card Guides 1-Slot, 3 Parts

- Extrusion: Aluminium
- End feet: plastic, UL94 V-0
- For card thickness: 1.6 mm / 0.06"
- Card guide extrusion, single, clear anodised
- ESD clip not usable

Extrusion

Card Depth		Length		Part-No. Aluminium
mm	inch	mm	inch	
160	6.30	112.5	4.43	66-122-20
220	8.66	172.5	6.79	66-122-21
280	11.02	232.5	9.15	66-122-22
340	13.38	292.5	11.51	66-122-23
400	15.74	352.5	13.87	66-122-24
		1350	53.15	66-122-14

End Feet

Description	Part-No. 1 Pair	Part-No. 50 Pairs
End feet plastic, UL94 V-0	61-069	63-030

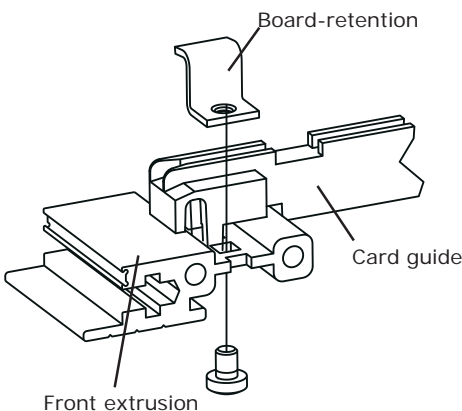

3.5.1.4 Card Guide Board-Retention Bar

Description	Part-No. 20 pcs.
Board-retention bar, zinc-plated steel	61-291

Assembly Material

Description	Part-No.
Cross recessed round head screw M3 x 4 (100 pcs.)	1912-04
Torx cylinder head screw M3 x 4, size T10 (1 pc.)	5470-01

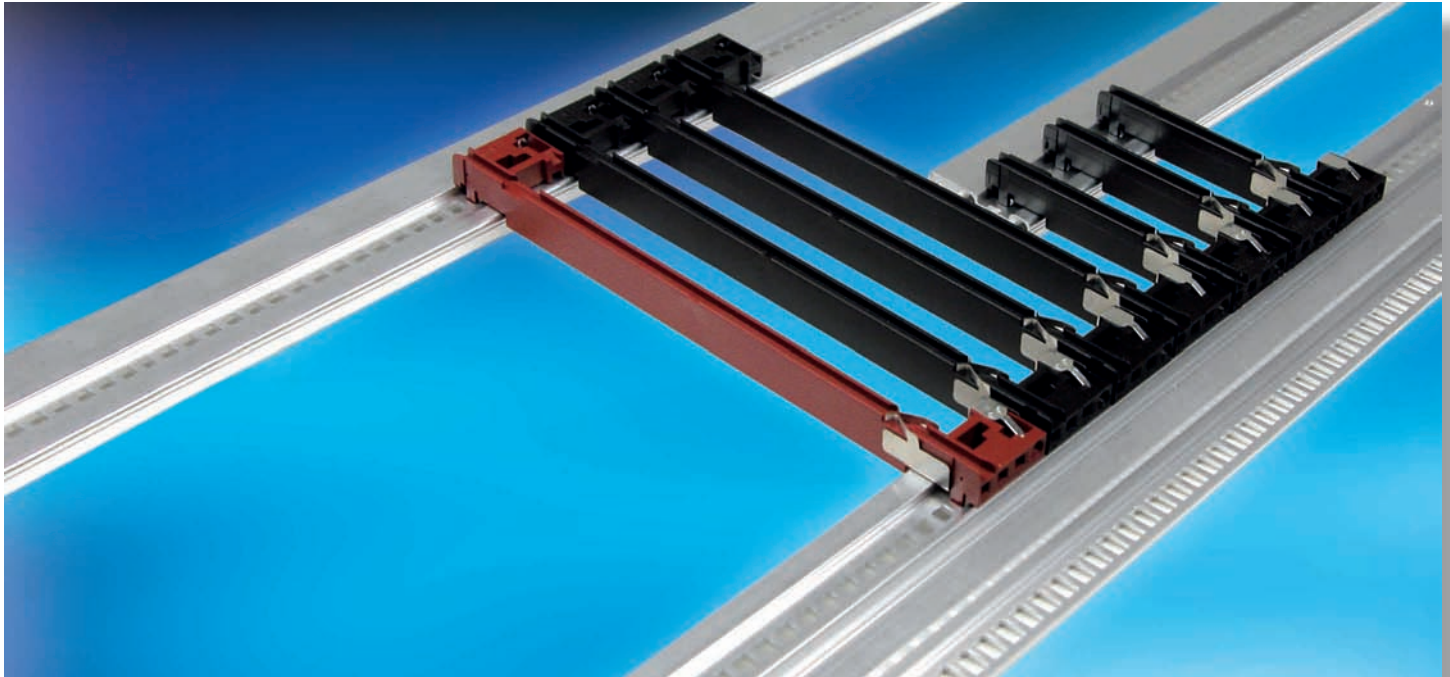

3.5.2 Card Guides acc. to IEEE

- For positive location of PCBs and plug-in units conforming to the dimensions of card depths 80 mm, 160 mm, 220 mm, 280 mm and 340 mm
- The card guides are non-flammable, made from a high quality plastic material reinforced with fibreglass UL94 V-0
- With ESD provisions
- With keying and alignment pin possibilities

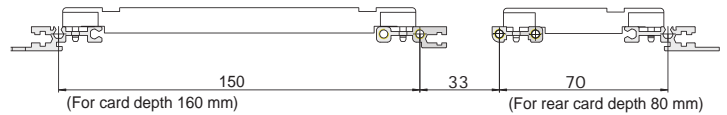

3.5.2.1 Card Guides 1-Slot

- Card thickness 1.6 mm / 0.06" and 2.0 mm / 0.08"
- Plastic UL94 V-0

Card Depth		Colour	Part-No. 5 Pairs	Part-No. 50 Pairs
mm	inch			
80	3.15	black	61-949-01-1	61-949-01-2

Card Depth		Colour	Part-No. 10 pcs.	Part-No. 100 pcs.
mm	inch			
160	6.30	black	61-950-01-1	61-950-01-2
160	6.30	red	61-950-03-1	61-950-03-2



3.5.2.2 Card Guides 1-Slot, incl. mounted ESD-Components

- Bottom: 1 ESD clip and 1 ESD spring
- Top: 1 ESD spring
- Black plastic UL94 V-0

Card Depth		Description	Part-No. 5 Pairs	Part-No. 50 Pairs
mm	inch			
80	3.15	1 pair top/bottom	61-949-02-1	61-949-02-2

Card Depth		Description	Part-No. 10 pcs.	Part-No. 100 pcs.
mm	inch			
160	6.30	1 piece bottom	61-950-02-1	61-950-02-2
160	6.30	1 piece top	61-950-04-1	61-950-04-2

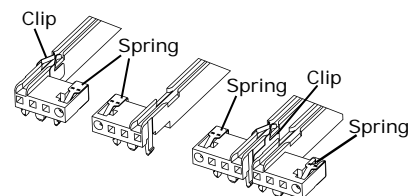
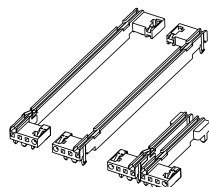



3.5.2.3.1 Aluminium Card Guides 1-Slot, 3 Parts

- Extrusion: Aluminium
- End feet: Plastic UL94 V-0
- For card thickness 1.6 mm / 0.06" and 2.0 mm / 0.08"

Extrusion

Card Depth		Part-No. 1 pc.	Part-No. 10 pcs.	Part-No. 100 pcs.
mm	inch			
160	6.30	66-452-20	66-452-20-1	66-452-20-2
220	8.66	66-452-25	66-452-25-1	66-452-25-2
280	11.02	66-452-30	66-452-30-1	66-452-30-2
340	13.38	66-452-35	66-452-35-1	66-452-35-2

End Feet

Colour	Part-No. 1 Pair	Part-No. 5 Pairs	Part-No. 50 Pairs
Black	61-955-01	61-955-01-1	61-955-01-2
Red	61-955-03	61-955-03-1	61-955-03-2

End Feet Offset

Colour	Part-No. 1 Pair	Part-No. 5 Pairs	Part-No. 50 Pairs
Pearlwhite	61-961-01	61-961-01-1	61-961-01-2



3.5.2.3.2 Aluminium Card Guides 1-Slot, 3 Parts

- Extrusion: Aluminium
- End feet: Plastic UL94 V-0
- For card thickness 2.4 mm / 0.094"

Extrusion

Card Depth		Part-No. 1 pc.	Part-No. 10 pcs.	Part-No. 100 pcs.
mm	inch			
160	6.30	66-453-20	66-453-20-1	66-453-20-2
220	8.66	66-453-25	66-453-25-1	66-453-25-2
280	11.02	66-453-30	66-453-30-1	66-453-30-2
340	13.38	66-453-35	66-453-35-1	66-453-35-2

End Feet

Colour	Part-No. 1 Pair	Part-No. 5 Pairs	Part-No. 50 Pairs
Black	61-956-01	61-956-01-1	61-956-01-2



3.5.2.4 ESD Clips

- Connecting printed board with case

Description	Part-No. 10 pcs.	Part-No. 100 pcs.
ESD clip front bottom/rear top	63-863	63-864
ESD clip front top/rear bottom	63-865	63-866

A



3.5.2.5 ESD Spring

- Connecting ESD pin with case
- Note: Notch inward-looking

Description	Part-No. 10 pcs.	Part-No. 100 pcs.
ESD spring	61-420-1	61-420-2



3.5.2.6 Coding Pins

- Acc. to IEC 60297-3-103
- Plastic, UL94 V-0
- Can be rotated in 4 positions

Description	Part-No. 1 pc.	Part-No. 100 pcs.
Grey	81-054-02	81-054-02-2
Dark red	81-054-06	81-054-06-2
Black	81-054-04	81-054-04-2

3: EMC Sub Rack Magic-/Spirit-Kit 11

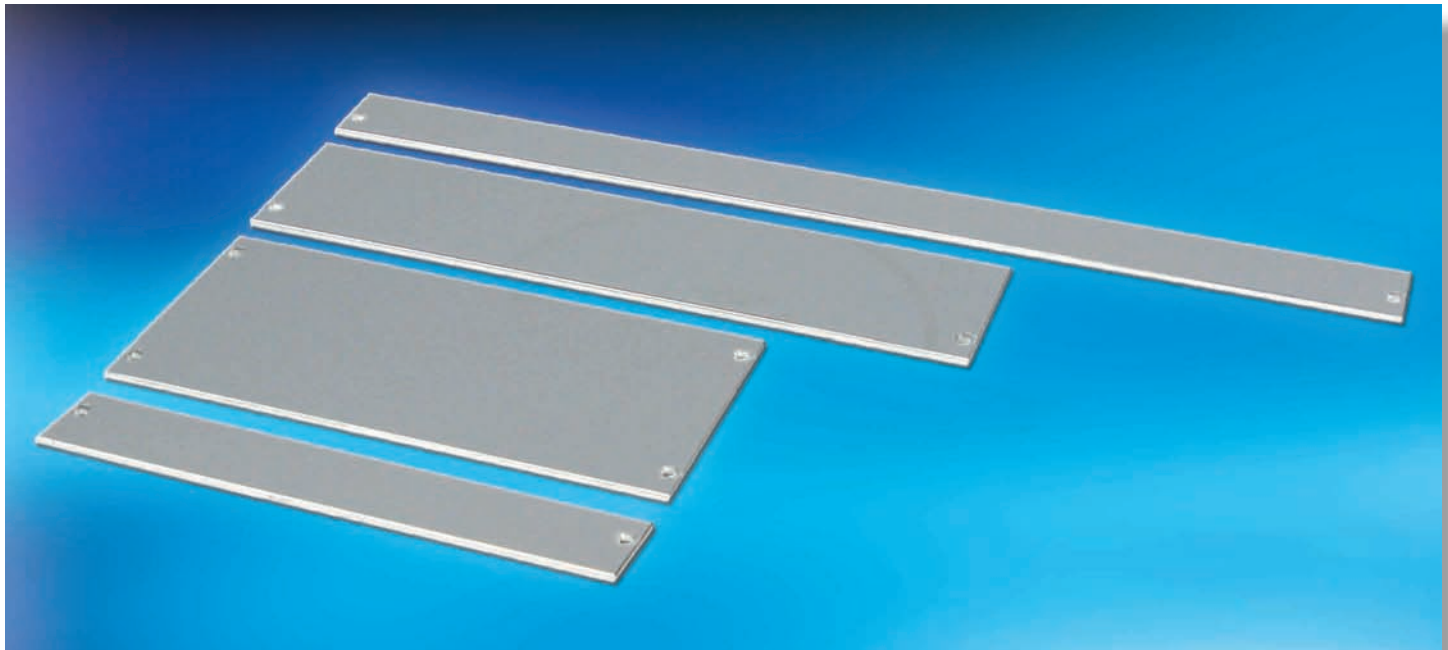

3.6 Front Panels

3.6.1 Flat Front Panels

- For sub racks and enclosures, solid
- Aluminium 2.5 mm, clear anodised (non-conductive)
- **Scope of delivery:**
 - Flat front panel
- Front panel screws, see below
- 1 HP and 2 HP are divider extrusions (not flat panels)

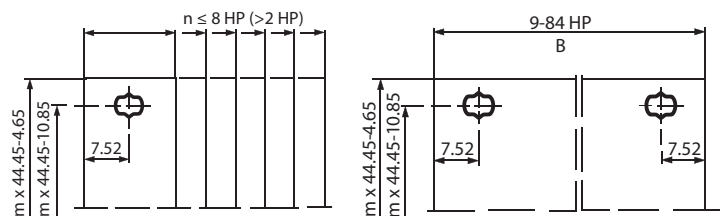

3.6.1 Flat Front Panels for Sub Racks and Enclosures, Solid

Width	B		Part-No.	
	mm	inch	3 U 128.7 mm	6 U 262.0 mm
1 HP	5.0	0.19	66-115-21	66-115-25
2 HP	10.0	0.39	66-107-44	66-107-47
3 HP	15.2	0.59	21N303	21N603
4 HP	20.1	0.79	21N304	21N604
5 HP	25.2	0.99	21N305	21N605
6 HP	30.3	1.19	21N306	21N606
7 HP	35.3	1.38	21N307	21N607
8 HP	40.4	1.59	21N308	21N608
10 HP	50.6	1.99	21N310	21N610
11 HP	55.7	2.19	21N311	
12 HP	60.7	2.38	21N312	21N612
14 HP	70.9	2.79	21N314	21N614
16 HP	81.1	3.19	21N316	21N616
20 HP	101.4	3.59	21N320	21N620
21 HP	106.5	4.19	21N321	21N621
28 HP	142.0	5.59	21N328	21N628
32 HP	162.3	6.38	21N332	
42 HP	213.1	8.38	21N342	21N642
52 HP	263.9	10.38	21N352	21N652
63 HP	319.8	12.59	21N363	21N663
81 HP	411.3	16.19	21N381	21N681
84 HP	426.5	16.79	21N384	21N684

- Other front panels see chapter C

Front Panel Screws

- Set of 10 screws, with screw retainer

Description	Part-No. 10 pcs.
Torx screws M2.5 x 11.3, size T8 with plastic screw retainer	63K159
Milled edge screws recessed M2.5 x 11.3 with plastic screw retainer	63-159

3.6.2 EMC Flat Front Panels

3.6.2.1 EMC Filler Panel with EMC Gasket

- High stability (U-profile)
- Extruded aluminium
- Pressed-in centring pin and bushes M2.5
- Front side clear anodised, rear side conductive
- **Scope of delivery:**
 - EMC front panel incl. pressed-in centering pin and bushes M2.5
- EMC-gasket see below
- Front panel screw see below



3.6.2.1 EMC Front Panel

Width	Part-No. 3 U	Part-No. 6 U
4 HP	66-514-73	66-514-76
5 HP	66-515-73	66-515-76
6 HP	66-516-73	66-516-76
8 HP	66-518-73	66-518-76
9 HP	66-519-73	66-519-76
10 HP	66-520-73	66-520-76
12 HP	66-522-73	66-522-76
14 HP	66-534-73	66-534-76

EMC Gasket (Stainless Steel)

Height	Part-No. 1 pc.	Part-No. 10 pcs.	Part-No. 100 pcs.
3 U	81-062-03	81-062-03-1	81-062-03-2
6 U	81-062-06	81-062-06-1	81-062-06-2

Front Panel Screws

- Front panel width up to 9 HP = 2 screws; ≥ 10 HP = 4 screws

Description	Part-No. 1 pc.	Part-No. 100 pcs.
Torx screw, M2.5 x 11.3, size T8	5443-08	1904K41
Round head screw, cross recessed M2.5 x 12.7	61-287	1904-41

3.6.2.2 EMC Filler Panel without EMC-Gasket

- Front panel standard, solid
- Front clear anodised
- Rear conductive
- Basic level EMC
- **Scope of delivery:**
 - 1 front panel incl. press-fit bushes M2.5 (pressed-in)
- Front panel screws, see below
- Spacer see next page

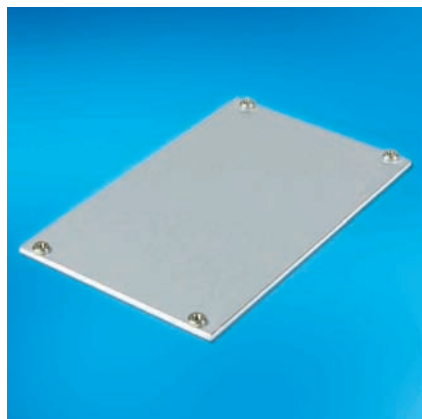

3.6.2.2 EMC Filler Panel without Gasket

Width	Part-No. 3 U	Part-No. 6 U
4 HP	21B304	
10 HP	21B310	
12 HP	21B312	
16 HP	21B316	
21 HP	21B321	21B621
42 HP	21B342	21B642
63 HP	21B363	21B663
84 HP	21B384	21B684

Front Panel Screws

- Front panel width up to 9 HP = 2 screws; ≥ 10 HP = 4 screws

Description	Part-No. 1 pc.	Part-No. 100 pcs.
Torx screw, M2.5 x 11.3, size T8	5443-08	1904K41
Round head screw, cross recessed M2.5 x 12.7	61-287	1904-41

3: EMC Sub Rack Magic-/Spirit-Kit 11



Spacer for EMC Front Panel Flat

- EMC-Level: Advanced
- **Scope of delivery:**
 - 1 spacer incl. gasket
 - 2 Torx sheet metal screws 2.9 x 6.5; size T 10

Height	Part-No.
3 U	81K023
6 U	81K026

Optional Cross Recessed Screws for Spacer (Torx round head screws as standard included)

Description	Part-No.
1 set (2 screws)	63-607

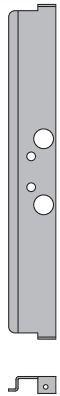

Holes in some cases needed for mounting telescopic rails

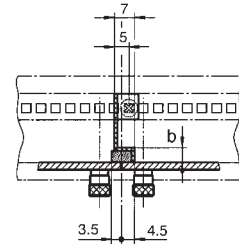
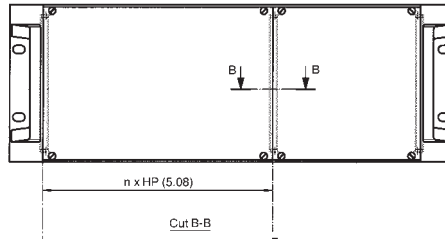

3.6.2.3 EMC Flat Front Panels

- Aluminium 2.5 mm (conductive)
- Closes the front or rear of the sub rack with very high shielding effectiveness
- Contact between the flat front panel and the case is made via EMC gaskets

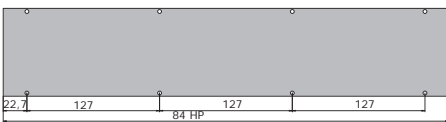
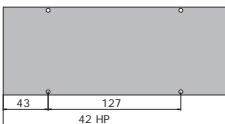

3.6.2.3 Advanced EMC Level

- **Scope of delivery:**
 - EMC flat front panel
 - Contact angle, incl. screws (6 U version only)
 - EMC gasket for contact angle (6 U version only)
- Front panel screws see below
 - Front panel width 42 HP = 4 screws
 - Front panel width 63 HP = 6 screws
 - Front panel width 84 HP = 8 screws

Width	Part-No. 3 U	Part-No. 6 U
42 HP	21C342	-
63 HP	21C363	
84 HP	21C384	21C684

Front Panel Screws

Description	Part-No. 10 pcs.
Torx screws M2.5 x 11.3, size T8, with press-fit bush	63K480
Screw recessed M2.5 x 11.3, with press-fit bush	63-444
Screw cross recessed M2.5 x 12.7, with press-fit bush	63-480

1 U - 3 U

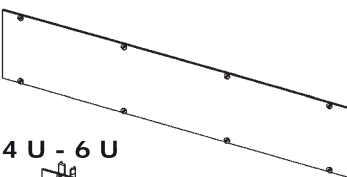

4 U - 6 U

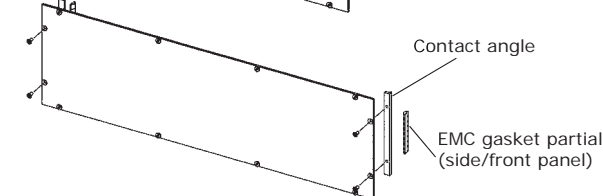

3: EMC Sub Rack Magic-/Spirit-Kit 11

A

3.6.2.4 Superior EMC Level

- **Scope of delivery:**
 - EMC flat front panel
 - Contact angle, incl. screws
 - EMC gasket for contact angle
 - EMC gasket for front extrusion/front panel
- Front panel screws, see below
 - Front panel width 42 HP = 4 screws
 - Front panel width 63 HP = 6 screws
 - Front panel width 84 HP = 8 screws

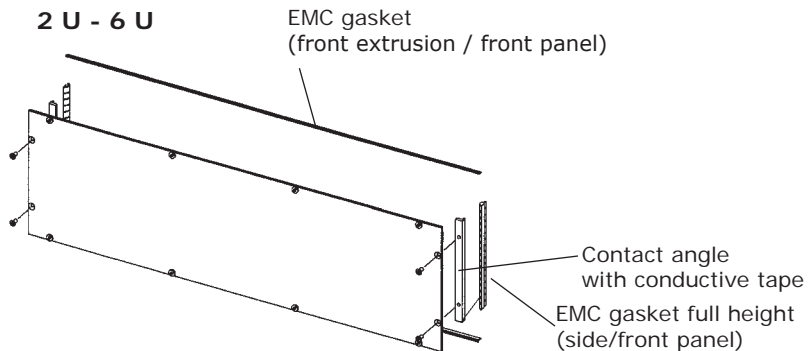

Width	Part-No. 3 U	Part-No. 6 U
42 HP	21D342	
63 HP	21D363	
84 HP	21D384	21D684

Front Panel Screws

Description	Part-No. 10 pcs.
Torx screws M2.5 x 11.3, size T8, with press-fit bush	63K480
Screw recessed M2.5 x 11.3, with press-fit bush	63-444
Screw cross recessed M2.5 x 12.7, with press-fit bush	63-480



3.6.3 Fan Front Panels

3.6.3.1 Fan Front Panel for Horizontal Ventilation

- Aluminium 2.5 mm, clear anodised (non-conductive)
- **Scope of delivery:**
 - 1 perforated fan front panel
- Front panel screws see below

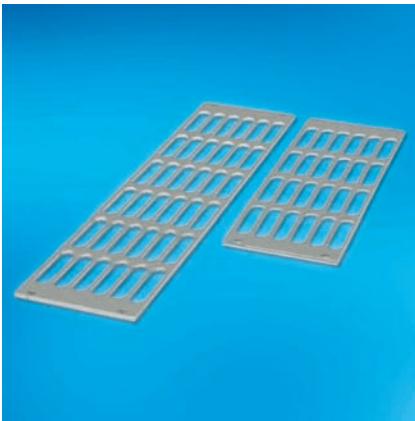
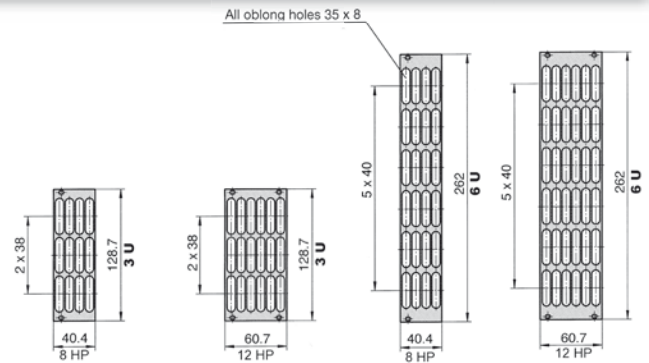

3.6.3.1 Fan Front Panel for Horizontal Ventilation

Height	Width	Air passage		Part-No.
		mm ²	sq. inch	
3 U	8 HP	3195	4.95	21N308-01
	12 HP	4793	7.42	21N312-01
6 U	8 HP	6390	9.90	21N608-01
	12 HP	9586	14.85	21N612-01

Front Panel Screws

- Set of 10 screws
- With screw retainer
- Fan front panel width up to 8 HP = 2 screws; ≥ 12 HP = 4 screws

Description	Part-No. 10 pcs.
Torx screws M2.5 x 11.3 , size T8, with plastic screw retainer	63K159
Milled edge screws recessed M2.5 x 11.3, with plastic screw retainer	63-159

3: EMC Sub Rack Magic-/Spirit-Kit 11

3.6.3.2 Fan Front Panels for Direct Fan Mounting

- Aluminium 2.5 mm, clear anodised (non-conductive)
- Scope of delivery:**
 - 1 perforated fan front panel
- Front panel screws see below
- Assembly material for fan mounting has to be ordered separately

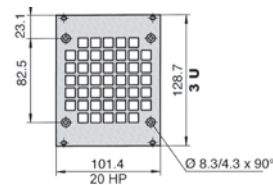

3.6.3.2 Fan Front Panels for Direct Fan Mounting

Description	Height	Width	Air passage		Part-No. 1 pc.
			mm ²	sq. inch	
Without switch opening	3 U	20 HP	4051	6.27	21N320-04

Front Panel Screws

- Set of 10 screws
- With screw retainer
- Per front panel 4 screws are needed

Description	Part-No. 10 pcs.
Torx screws M2.5 x 11.3 , size T8, with plastic screw retainer	63K159
Milled edge screws recessed M2.5 x 11.3, with plastic screw retainer	63-159

Assembly Material for Fan Mounting

Description	Part-No. 100 pcs.
Countersunk screw, recessed M4 x 10	1906-24
Hexagonal nut M4, 0.8D	1907-20



3.6.4 Hinged Front Panels

3.6.4.1 Top/Bottom-Hinged Front Panel

- Hinges are attached to the front extrusions of the sub rack or case
- Aluminium 2.5 mm, clear anodised (non-conductive)
- **Scope of delivery:**
 - Front panel
 - Hinge extrusion
 - Assembly material M2.5, incl. hinges

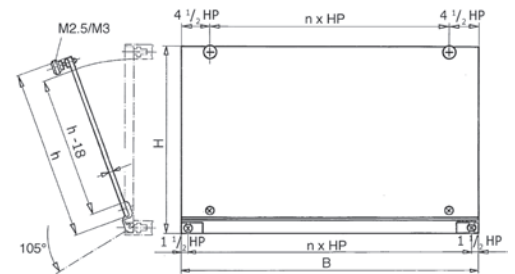

3.6.4.1 Top/Bottom-Hinged Front Panel

Width	Part-No. 3 U	Part-No. 6 U
63 HP	25N363-19	
84 HP	25N384-19	25N684-19

Dimensions

HP	Nominal Width		Width B	
	mm	inch	mm	inch
63 HP	320.04	12.60	319.8	12.59
84 HP	426.72	16.80	426.5	16.79

Nominal Height U	Height H		Height h	
	mm	inch	mm	inch
3 U	128.7	5.07	117	4.61
6 U	262.05	10.31	250.3	9.85

3: EMC Sub Rack Magic-/Spirit-Kit 11

3.6.4.2 EMC Top / Bottom-Hinged Front Panel

- Width: 84 HP
- Offers optimum protection from electromagnetic interference
- Aluminium 2.5 mm, front anodised, rear conductive
- **Scope of delivery:**
 - EMC front panel
 - Hinge extrusions
 - Assembly material M2.5, incl. hinges
 - EMC gaskets

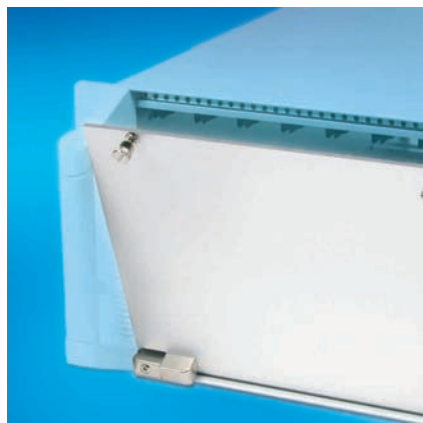

3.6.4.2 EMC Top / Bottom-Hinged Front Panel

EMC Level	Part-No. 3 U	Part-No. 6 U
Advanced	25C384-11	25C684-11
Superior	25D384-11	25D684-11

3.6.4.3 Side-Hinged Front Panel

- Aluminium 2.5 mm, clear anodised (non-conductive)
- **Scope of delivery:**
 - Front panel
 - Hinge extrusion
 - Assembly material M2.5, incl. hinges



3.6.4.3 Side-Hinged Front Panel

Width	Part-No. 3 U	Part-No. 6 U
42 HP	25N342-29	25N642-29
63 HP	25N363-29	25N663-29
84 HP	25N384-29	25N684-29

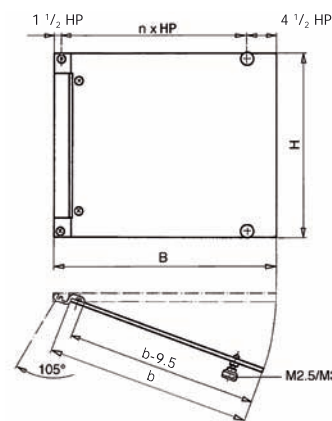

Dimensions

HP	Nominal Width		Width B		Width b	
	mm	inch	mm	inch	mm	inch
42 HP	213.36	8.40	213.1	8.39	201	7.91
63 HP	320.04	12.60	319.8	12.59	307.7	12.11
84 HP	426.72	16.80	426.5	16.79	414.3	16.31

Nominal Height	Height H	
U	mm	inch
3 U	128.7	5.06
6 U	262.05	10.31

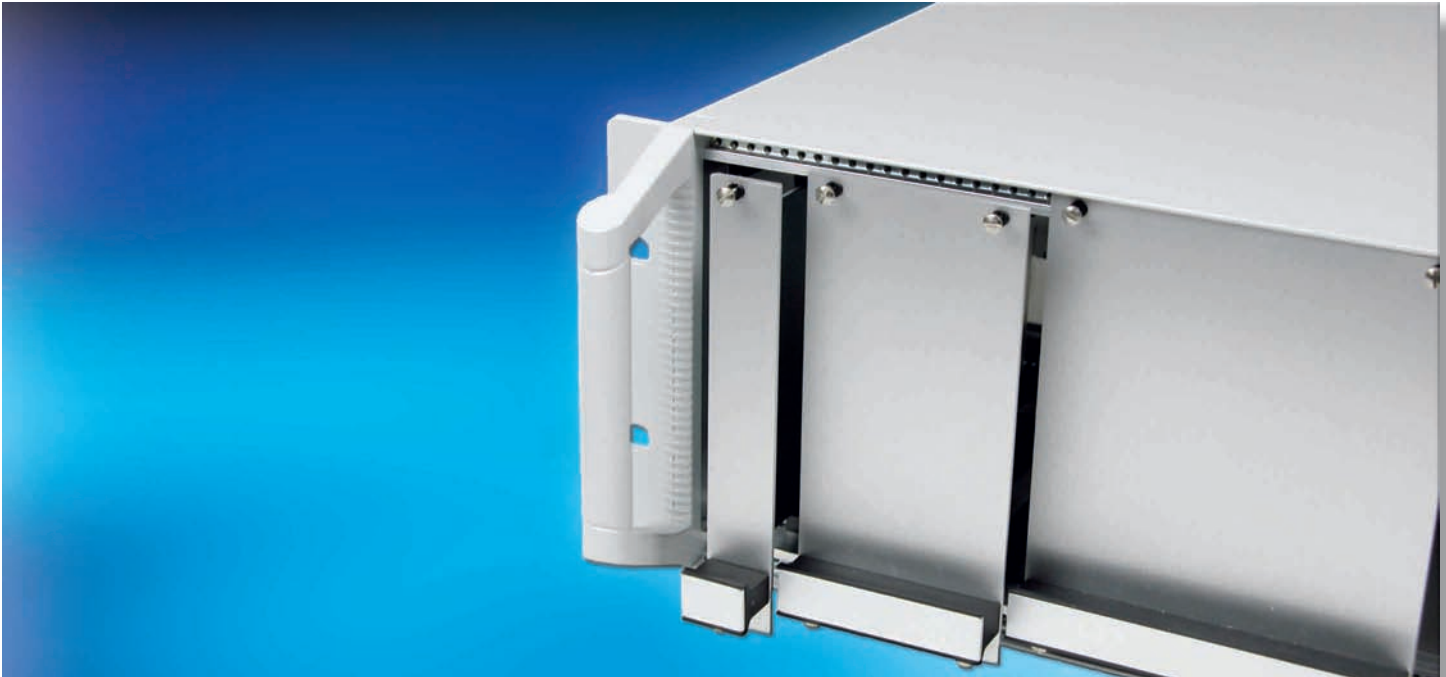

3.6.5 Plug-In Units acc. to IEC

3.6.5.1 Extruded Front Panel

- Aluminium 2.5 mm, clear anodised (non-conductive)
- PCB mounting lugs are formed on the rear face of the panel
- No PCB fixing screws on the front face of the panel, leaving more space for silk screening and mounting front panel components
- Suitable for all sub racks and cases
- Thickness of the mounting lugs (3.48 mm) allows PCBs to be mounted on either side of the lugs
- Drill marks at rear for handle-fixing holes
- **Scope of delivery:**
 - Extruded front panel, clear anodised
 - Front panel screws see below

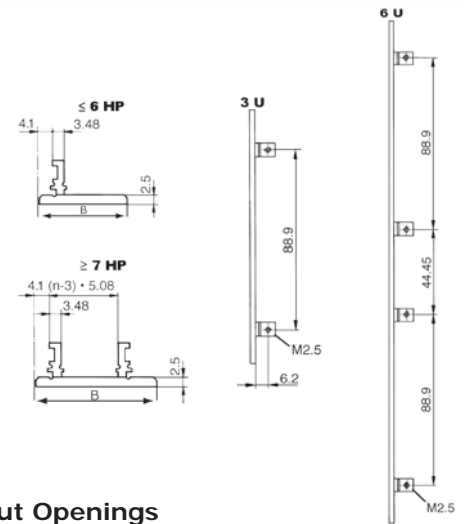

3.6.5.1 Extruded Front Panels, without Openings

Width	B		Part-No. 3 U	Part-No. 6 U
	mm	inch		
3 HP	15.0	0.59	26N303	26N603
4 HP	20.1	0.79	26N304	26N604
5 HP	25.2	0.99	26N305	26N605
6 HP	30.3	1.19	26N306	26N606
7 HP	35.3	1.38	26N307	26N607
8 HP	40.4	1.59	26N308	26N608
10 HP	50.6	1.99	26N310	26N610
12 HP	60.7	2.38	26N312	26N612
14 HP	70.9	2.79	26N314	26N614
16 HP	81.1	3.19	26N316	26N616
21 HP	106.5	4.19	26N321	

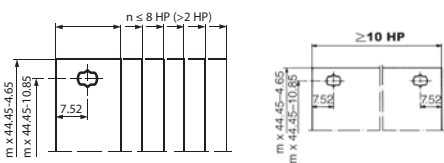

Front Panel Screws

- Set of 10 screws
- With screw retainer
- Front panel width up to 9 HP = 2 screws; ≥ 10 HP = 4 screws

Description	Part-No. 10 pcs.
Torx screws M2.5 x 11.3 , size T8, with plastic screw retainer	63K159
Milled edge screws recessed M2.5 x 11.3, with plastic screw retainer	63-159

3: EMC Sub Rack Magic-/Spirit-Kit 11

3.6.5.2 Rigid-Mounted Unit Handles with Identification Label

- Black, plastic UL94 V-0, label aluminium anodised
- **Scope of delivery:**
 - Rigid-mounted handle
 - Identification label
- Assembly material see below

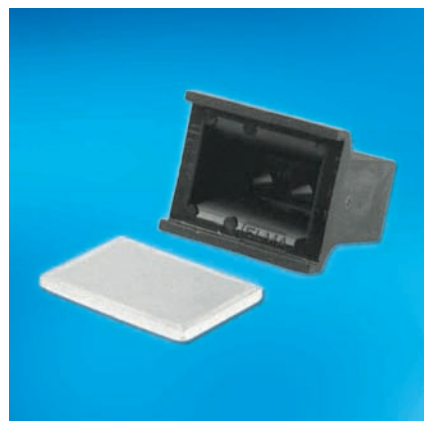
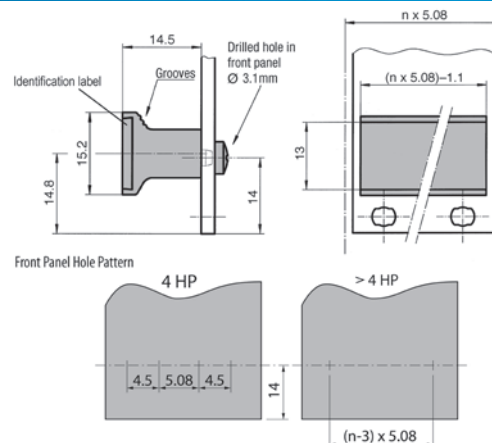

Rigid-Mounted Handle with Identification Label

Width	Scope of Delivery	Part-No.
4 HP top*	5 pcs.	60-200-01
4 HP bottom*	5 pcs.	60-200-02
4 HP	10 pcs.	60-200-04
5 HP	10 pcs.	60-200-05
6 HP	10 pcs.	60-200-06
7 HP	10 pcs.	60-200-07
8 HP	10 pcs.	60-200-08
10 HP	10 pcs.	60-200-10
12 HP	10 pcs.	60-200-12
14 HP	1 pc.	60-200-14
21 HP	1 pc.	60-200-21

- Other sizes (up to 84 HP) are available upon request
- * (Flat front panel with card holder)

Assembly Material

Description	Part-No. 1 pc.	Part-No. 100 pcs.
Recessed round head screw	61-276	1902-70

3.6.5.3 Fluted Handles

- Extruded aluminium handles, shaped to facilitate withdrawal of plug-in units
- Two grooves in the front face will accept identification strips (0.5 x 9 mm)
- **Scope of delivery:**
 - Extruded handle, clear anodised
 - Assembly material

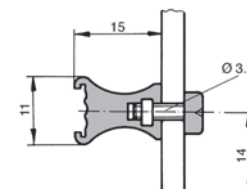

Fluted Handles for Front Panels to IEC

Front Panel Width HP	Width		Handle Length		Part-No.
	mm	inch	mm	inch	
3 HP	15.0	0.59	12.5	0.49	60-103
4 HP	20.1	0.79	17.6	0.69	60-104
5 HP	25.2	0.99	22.6	0.88	60-105
6 HP	30.3	1.19	27.7	1.09	60-106
7 HP	35.3	1.38	33.5	1.31	60-107
8 HP	40.4	1.59	37.9	1.49	60-108
10 HP	50.6	1.99	48.0	1.88	60-110
12 HP	60.8	2.39	58.2	2.29	60-112
14 HP	70.9	2.79	69.1	2.72	60-114
16 HP	81.1	3.19	78.5	3.09	60-116
20 HP	101.4	3.99	98.8	3.88	60-120
21 HP	106.5	4.18	104.6	4.11	60-121
27 HP	137.0	5.39	134.4	5.29	60-127
30 HP	152.2	5.99	149.6	5.88	60-130
40 HP	203.0	7.99	200.4	7.88	60-140
60 HP	304.6	11.99	302.0	11.88	60-160
84 HP	426.5	16.79	424.0	16.69	60-184

3: EMC Sub Rack Magic-/Spirit-Kit 11

3.6.5.4 Front Panel with Cutouts for IEC Ejector Handles

- Aluminium 2.5 mm, clear anodised (non-conductive)
- PCB mounting lugs are formed on the rear face of the panel (only 3 U-Version)
- No PCB fixing screws on the front face of the panel, leaving more space for silk screening and mounting front panel components
- Suitable for all sub racks and cases
- 3 U front panels prepared for one handle
- 6 U front panels prepared for two handles
- **Scope of delivery:**
 - Front panel, clear anodised
- Front panel screws see below (for 3 U-Version only)
- IEC ejector handles, see 3.6.5.5

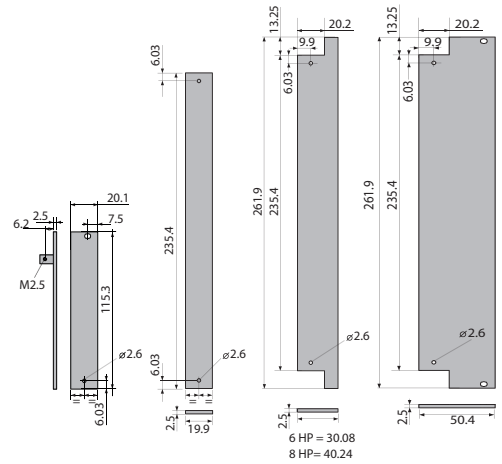

3.6.5.4 Front Panel with Cutout for IEC Ejector Handle

Width	B		Part-No. 3 U	Part-No. 6 U
	mm	inch		
4 HP	20.0	0.79	26N304-51	21N604-51
6 HP	30.2	1.19		21N606-51
8 HP	40.3	1.59		21N608-51
10 HP	50.5	1.99		21N610-51

Front Panel Screws (for 3 U-Version only)

- Set of 10 screws
- With screw retainer
- Front panel 3 U = 1 screw

Description	Part-No. 10 pcs.
Torx screws M2.5 x 11.3, size T8, with plastic screw retainer	63K159
Milled edge screws recessed M2.5 x 11.3, with plastic screw retainer	63-159

3.6.5.5 Ergonomic Ejector Handles acc. to IEC

- Simple assembly of plug-in units
- Allows trouble-free extraction of electronic units with multi-pole connectors
- Main features in one part: card holder, ejector handle and centring pin
- Reset spring for safe insertion
- One version for top and bottom only
- Handle is injection moulded, glass-reinforced plastic, UL94 V-0
- Card holder is zinc die-cast, nickel plated
- Reset spring is stainless steel
- **Scope of delivery:**
 - Ejector handle
 - Assembly material (cross recessed screws M2.5 for fixing of card holder/printed board/front panel)
- Front panel with special cutouts have to be ordered separately

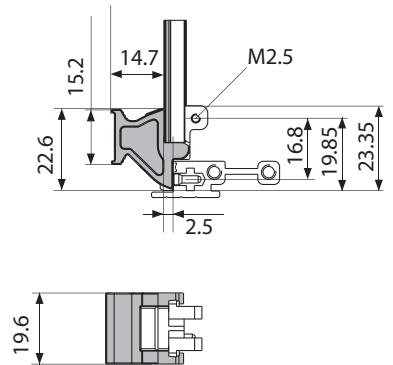

3.6.5.5 Ejector Handle acc. to IEC

Description	Part-No. 10 pcs.	Part-No. 100 pcs.
Ejector handle black	81-233-1	81-233-2
Ejector handle grey	81-234-1	81-234-2

Extraction process:

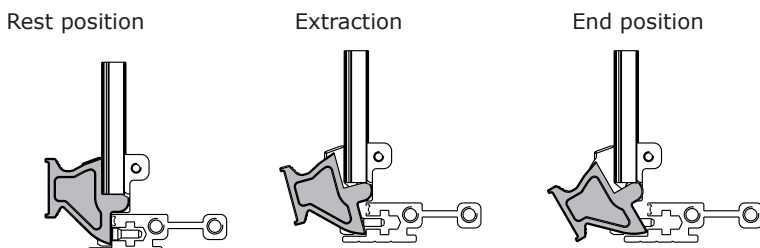

Label

Description	Part-No.
1 sheet A4 of 220 labels	81-031



3.6.6 EMC Plug-In Units acc. to IEC

- Excellent EMC shielding
- Made of aluminium extrusions
- Rear side: conductive surface finish (clear passivated)
- Used in the assembly of plug-in units
- The EMC-gasket is integrated into the front panel profile to protect it from damage
- A pressfit centering pin guarantees optimum positioning of the panel as well as the right pressure between the contact strip and the next panel



3.6.6.1 EMC Filler Panel without Openings

- High stability
- Extruded aluminium
- Pressed-in centering pin and bushes M2.5
- Front side clear anodised, rear side conductive
- **Scope of delivery:**
 - EMC front panel, incl. pressed-in centering pin and bushes M2.5
- EMC-gasket see below
- Front panel screw see below
- Handles and card holders cannot be fitted with this type of front panel

Width	Part-No. 3 U	Part-No. 6 U
4 HP	66-514-73	66-514-76
6 HP	66-516-73	66-514-76
8 HP	66-518-73	66-518-76



EMC Gasket (Stainless Steel)

Height	Part-No. 1 pc.	Part-No. 10 pcs.	Part-No. 100 pcs.
3 U	81-062-03	81-062-03-1	81-062-03-2
6 U	81-062-06	81-062-06-1	81-062-06-2

Front Panel Screws

- Front panel width up to 8 HP = 2 screws

Description	Part-No. 1 pc.	Part-No. 100 pcs.
Torx screw, M2.5 x 11.3, size T8	5443-08	1904K41
Round head screw, cross recessed M2.5 x 12.7	61-287	1904-41

Use Elma's front panel service for machining and screen printing of your panels!

3: EMC Sub Rack Magic-/Spirit-Kit 11

3.6.6.2 EMC Front Panels for IEC Plug-In Units with Cutouts for Ejector Handles acc. to IEC

- EMC Front Panels Aluminium with EMC Gasket
- Excellent EMC shielding
- Immune to snagging
- EMC-gasket slides onto the extrusion
- **Scope of delivery:**
 - EMC front panel, incl. pressed-in bushes M2.5 (size ≥ 9 HP)
- EMC-gasket see below
- Handle has to be ordered separately, see 3.6.6.4
- Front panel screw (size ≥10 HP), see below



3.6.6.2 Front Anodised, Rear Conductive (2 cutouts)

- With 2 cutouts (bottom + top)

Width	Part-No. 3 U	Part-No. 6 U	Part-No. 9 U
4 HP	66-514-23	66-514-26	66-514-29
5 HP	66-515-23	66-515-26	-
6 HP	66-516-23	66-516-26	66-516-29
8 HP	66-518-23	66-518-26	66-518-29
9 HP	66-519-23	66-519-26	-
10 HP	66-520-23	66-520-26	66-520-29
12 HP	66-522-23	66-522-26	66-522-29
14 HP	66-534-23	66-534-26	

3.6.6.2.1 Front Anodised, Rear Conductive (1 cutout)

- With 1 cutout (bottom)
- Incl. pressed-in centring pin and bush M2.5 (top)
- Incl. cutout for mounting of card holder 61-156 (top) with screw 5322-08 (see 3.6.6.5)

Width	Part-No. 3 U
4 HP	66-514-43
5 HP	66-515-43
6 HP	66-516-43
8 HP	66-518-43
9 HP	66-519-43
10 HP	66-520-43
12 HP	66-522-43
14 HP	66-534-43

3.6.6.2.2. Front and Rear Side Raw

- With 2 cutouts (bottom + top)

Width	Part-No. 3 U	Part-No. 6 U
4 HP	66-514-63	66-514-66
6 HP	66-516-63	66-516-66
8 HP	66-518-63	66-518-66
10 HP	66-520-63	66-520-66
12 HP	66-522-63	66-522-66

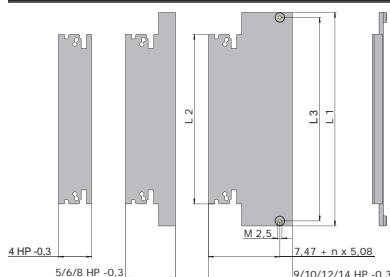

Dimensions

Height	L1 mm	L1 inch	L2 mm	L2 inch	L3 mm	L3 inch
3 U	128.55	5.06	102.05	4.01	122.50	4.82
6 U	261.90	10.31	235.40	9.27	255.85	10.07
9 U	395.25	15.56	368.75	14.51	389.20	15.32

3: EMC Sub Rack Magic-/Spirit-Kit 11

A



3.6.6.3 EMC-Gasket (Stainless Steel)

Unit	Part-No. 3 U	Part-No. 6 U	Part-No. 9 U
1 pc.	81-062-03	81-062-06	81-062-09
10 pcs.	81-062-03-1	81-062-06-1	81-062-09-1
100 pcs.	81-062-03-2	81-062-06-2	81-062-09-2

3.6.6.3.1 Front Panel Screw

- For EMC front panels size ≥ 10 HP = 2 additional screws are needed

Description	Part-No. 2 pcs.	Part-No. 100 pcs.
Cross recessed round head screws M2.5 x 12.7	61-287-4	1904-41
Torx screws M2.5 x 11.3, size T8	63K482	1904K41

3.6.6.4 Ergonomic Ejector Handles acc. to IEC

- Simple assembly of plug-in units
- Allows trouble-free extraction of electronic units with multi-pole connectors
- Main features in one part: card holder, ejector handle and centring pin
- Reset spring for safe insertion
- One version for top and bottom only
- Handle is injection moulded, glass-reinforced plastic, UL94 V-0
- Card holder is zinc die-cast, nickel plated
- Reset spring is stainless steel
- Scope of delivery:**
 - Ejector handle
 - Assembly material (cross recessed screws M2.5 for fixing of card holder/printed board/front panel)
- Front panel with special cutouts have to be ordered separately

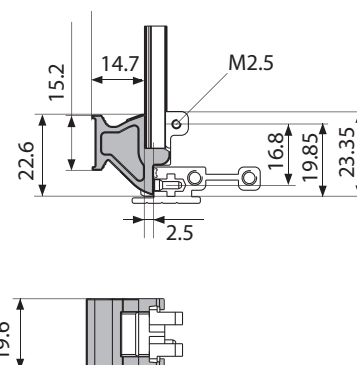

3.6.6.4 Ejector Handle acc. to IEC

Description	Part-No. 10 pcs.	Part-No. 100 pcs.
Ejector handle black	81-233-1	81-233-2
Ejector handle grey	81-234-1	81-234-2

Extraction process:

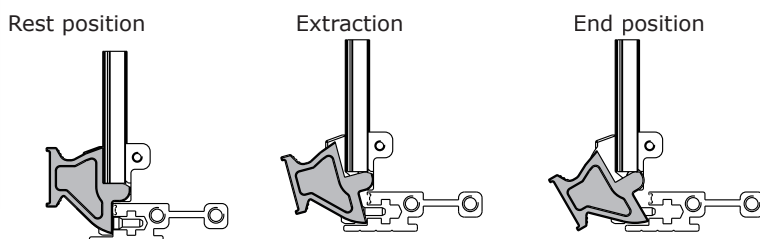

Label

Description	Part-No.
1 sheet A4 of 220 labels	81-031

3: EMC Sub Rack Magic-/Spirit-Kit 11

A

3.6.6.5 Card Holder acc. to IEC Standard

- By using the zinc die-cast card holder, flat front panels and EMC front panels acc. to IEC can be connected to a PC card to form a plug-in unit
- The card can be mounted both in the standard position and offset 1 HP (5.08 mm)
- **Scope of delivery:**
 - Card holder
- Assembly material see below



3.6.6.5 Card Holder without Swivel Stop

Description	Application	D	Part-No. 1 pc.	Part-No. 10 pcs.	Part-No. 100 pcs.
Card holder without swivel stop	Without injector / ejector handle	M2.5	61-156	63-366	63-466

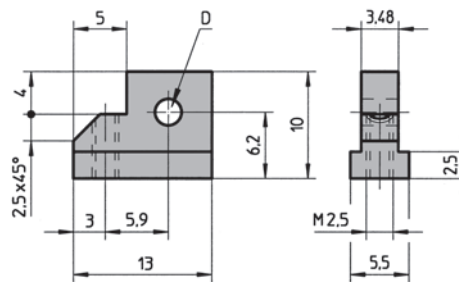

Assembly Material

Description	Application	Part-No. 1 pc.	Part-No. 100 pcs.
Cross recessed counter-sunk screw M2.5 x 8	For card holder	5322-08	1906-08
Torx countersunk screw M2.5 x 8, size T8	For card holder	5470-21	
Slotted pan head screw M2.5 x 6	For printed board	5571-06	1901-06
Torx cylinder head screw M2.5 x 6, size T8	For printed board	5470-04	

3.6.6.6 Card Holder/End Piece without ESD Pin

- **Scope of delivery:**
 - End piece card holder (zinc die-cast, nickel plated)
 - Assembly material (screws M2.5 for fixing of front panel/card holder/printed board)

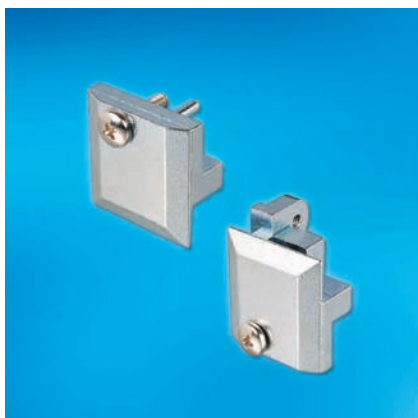

Card Holder/End Piece *without* ESD Pin

Description	Part-No. 1 pc.	Part-No. 100 pcs.
Top	81-018-01	81-018-01-2
Bottom	81-019-01	81-019-01-2



3.6.7 Plug-In Units acc. to IEEE

3.6.7.1 EMC Front Panels Aluminium with EMC Gasket acc. IEEE

- Excellent EMC shielding
- Immune to snagging
- EMC-gasket slides onto the extrusion
- **Scope of delivery:**
 - EMC front panel, incl. press-in bushes M2.5 (size \geq 10 HP)
- EMC-gasket see below
- Handle has to be ordered separately, see 3.6.7.5
- Front panel screw (size \geq 10 HP), see below



3.6.7.1 Front Anodised, Side Conductive (2 cutouts)

- With 2 cutouts (bottom + top)

Width	Part-No. 3 U	Part-No. 6 U
4 HP	66-514-23	66-514-26
5 HP	66-515-23	66-515-26
6 HP	66-516-23	66-516-26
8 HP	66-518-23	66-518-26
9 HP	66-519-23	66-519-26
10 HP	66-520-23	66-520-26
12 HP	66-522-23	66-522-26
14 HP	66-534-23	66-534-26

3.6.7.2 Front Anodised, Rear Conductive (1 cutout)

- With 1 cutout (bottom)
- Incl. pressed-in centring pin and bush M2.5 (top)
- Incl. cutout for mounting of card holder 61-156 (top) with screw 5322-08 (see 2.7.6.2)

Width	Part-No. 3 U
4 HP	66-514-43
5 HP	66-515-43
6 HP	66-516-43
8 HP	66-518-43
9 HP	66-519-43
10 HP	66-520-43
12 HP	66-522-43
14 HP	66-534-43

3.6.7.3 Front and Rear Side Raw

- With 2 cutouts (bottom + top)

Width	Part-No. 3 U	Part-No. 6 U
4 HP	66-514-63	66-514-66
6 HP	66-516-63	66-516-66
8 HP	66-518-63	66-518-66
10 HP	66-520-63	66-520-66
12 HP	66-522-63	66-522-66

3: EMC Sub Rack Magic-/Spirit-Kit 11

A



EMC-Gasket (Stainless Steel)

Unit	Part-No. 3 U	Part-No. 6 U
1 pc.	81-062-03	81-062-06
10 pcs.	81-062-03-1	81-062-06-1
100 pcs.	81-062-03-2	81-062-06-2

Front Panel Screw

- For EMC front panels size ≥ 10 HP = 2 additional screws are needed

Description	Part-No. 2 pcs.	Part-No. 100 pcs.
Cross recessed round head screws M2.5 x 12.7	61-287-4	1904-41
Torx screws M2.5 x 11.3, size T8	63K482	1904K41

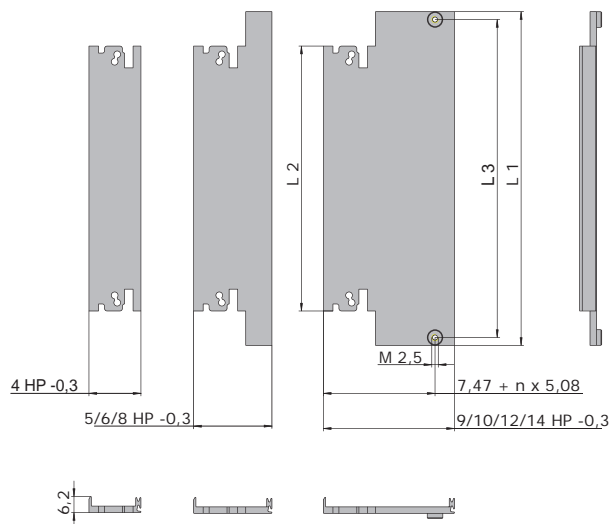

Dimensions

Height	L1 mm	L1 inch	L2 mm	L2 inch	L3 mm	L3 inch
3 U	128.55	5.06	102.05	4.01	122.50	4.82
6 U	261.90	10.31	235.40	9.27	255.85	10.07

3.6.7.4 EMC Front Panel Stainless Steel acc. IEEE

- Very good EMC shielding
- Economic solution
- EMC-spring integrated in front panel
- Stainless steel
- Scope of delivery:**
 - EMC front panel
- Handle has to be ordered separately, see 3.6.7.5

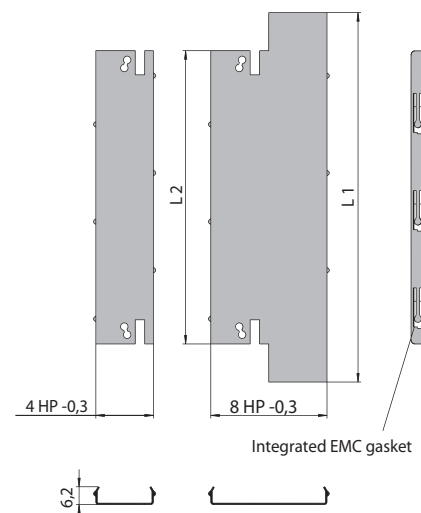

3.6.7.4 Front and Rear Side Untreated, Stainless Steel

Width	Part-No. 3 U	Part-No. 6 U
4 HP	28-304	28-604
8 HP	28-308	28-608