

STP-1230

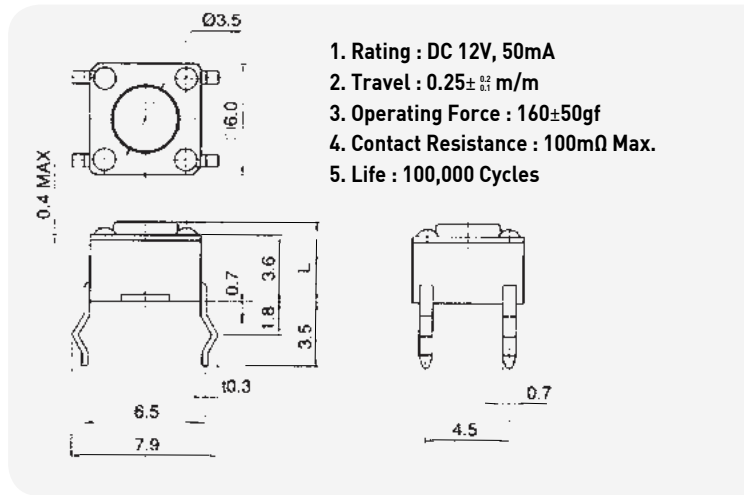

Model No.	Operating Force	Stem Color
STP-1230	160 ±50gf	See Below
STP-1230W	260±50gf	Red



Model No.	STP 1230	STP 1230A	STP 1230B	STP 1230C	STP 1230D	STP 1230E	STP 1230F	STP 1230G	STP 1230J
L	4.3	5.0	9.5	8.0	13.0	7.3	8.5	7.0	17.0
Stem Color	Black	Black	Black	White	Black	Ivory	Gray	Black	Black

STP-1236

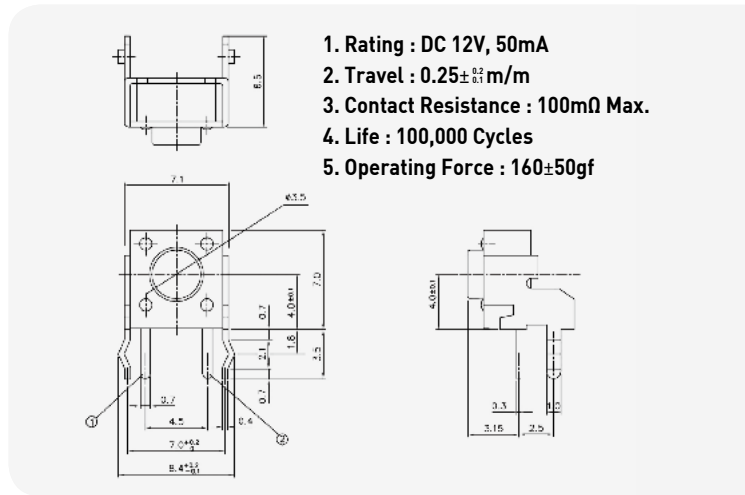

Model No.	STP 1236	STP 1236A	STP 1236B	STP 1236C	STP 1236D	STP 1236E	STP 1236F	STP 1236G	STP 1236J
L	3.15	3.85	8.35	6.85	11.85	6.15	7.35	5.85	15.85
Stem Color	Black	Black	Black	White	Black	Ivory	Gray	Black	Black

STP-1232



Model No.	Operating Force	Stem Color
STP-1232	160 ±50gf	See Below
STP-1232W	260±50gf	Red

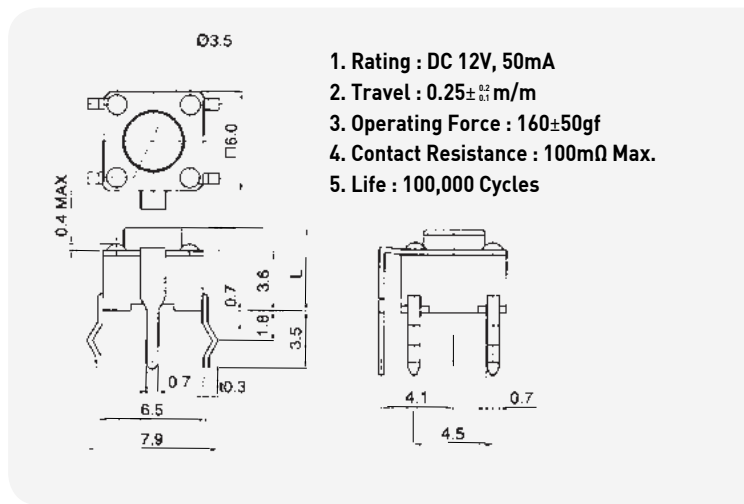

Model No.	STP 1232	STP 1232A	STP 1232B	STP 1232C	STP 1232D	STP 1232E	STP 1232F	STP 1232G	STP 1232J
L	4.3	5.0	9.5	8.0	13.0	7.3	8.5	7.0	17.0
Stem Color	Black	Black	Black	White	Black	Ivory	Gray	Black	Black

STP-1236T

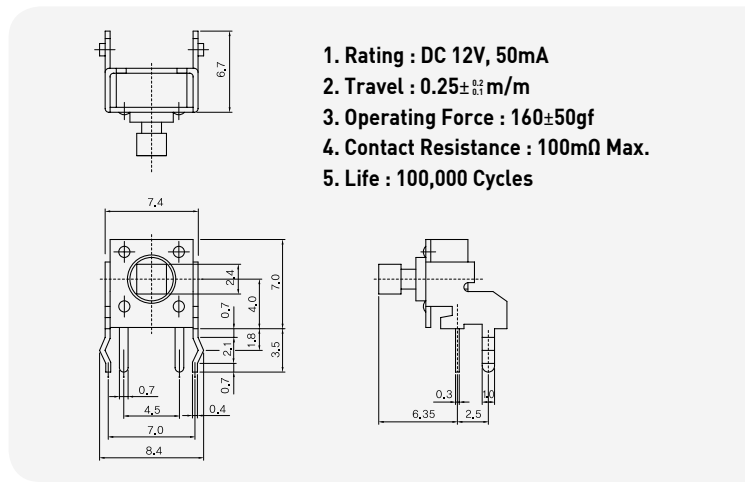

STP-1145

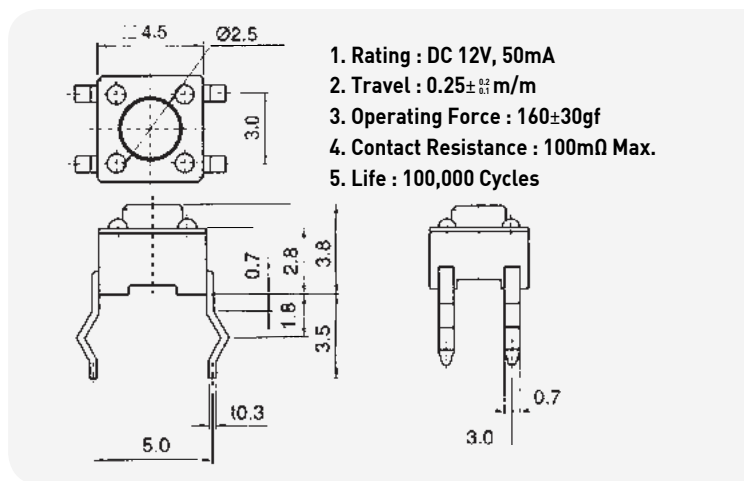

STP-1117

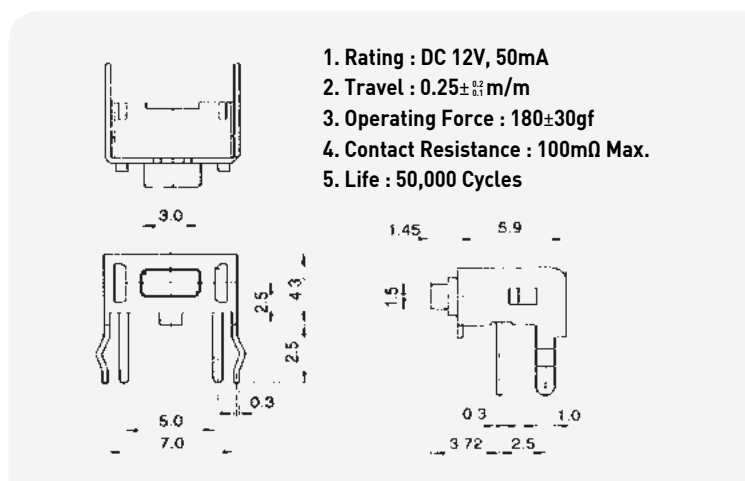

Model No.	Operating Force	Stem Color
STP 1117	180±30gf	Black
STS 1117W	260±50gf	Red

STP-1243



Model No.	Operating Force	Case Color
STP-1243	180 ±30gf	Black
STP-1243W	260±50gf	White

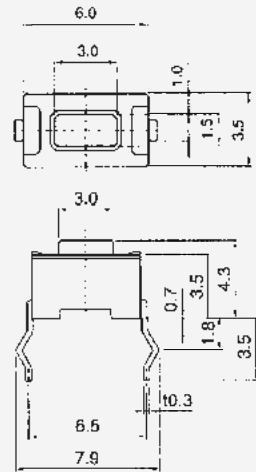

1. Rating : DC 12V, 50mA
2. Travel : 0.25±0.05 m/m
3. Contact Resistance : 100mΩ Max.
4. Life : 50,000 Cycles

STP-1250



Model No.	Operating Force	Case Color
STP-1250	180 ±30gf	Black
STP-1250W	260±50gf	White

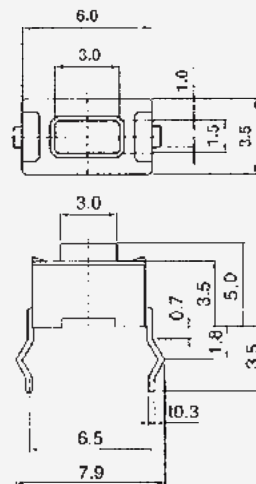

1. Rating : DC 12V, 50mA
2. Travel : 0.25±0.05 m/m
3. Contact Resistance : 100mΩ Max.
4. Life : 50,000 Cycles

STP-1243S  
STP-1250S



Model No.	Stem(L)	Operating Force
STP-1243S	4.3mm	180 ±30gf
STP-1250S	5.0mm	180 ±30gf
STP-1243SW	4.3mm	260±50gf
STP-1250SW	5.0mm	260±50gf

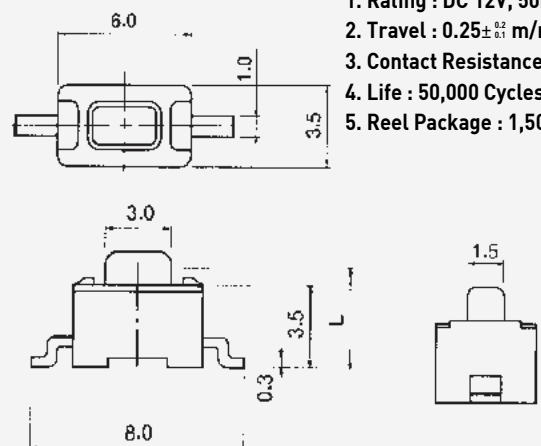

1. Rating : DC 12V, 50mA
2. Travel : 0.25±0.05 m/m
3. Contact Resistance : 100mΩ Max.
4. Life : 50,000 Cycles
5. Reel Package : 1,500PCS/REEL

LED TACT SWITCHES

STP-1194

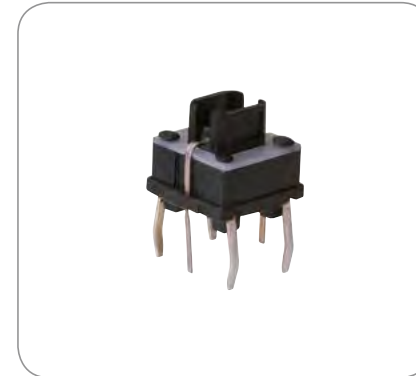

Model No.	Color (Led)
STP 1194R	Red
STP 1194G	Green
STP 1194Y	Yellow

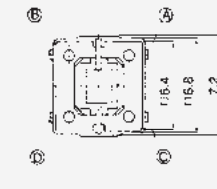

CIRCUIT DIAGRAM

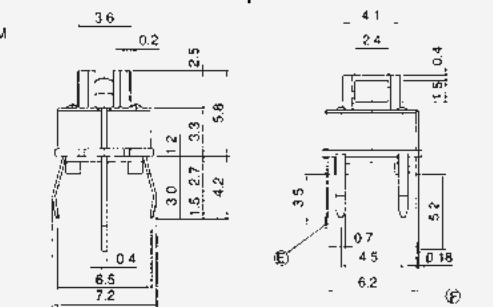
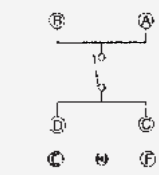

1. Rating : DC 12V, 50mA
2. Travel : 0.25±0.05 m/m
3. Operating Force : 160±30gf
4. Contact Resistance : 100mΩ Max.
5. Life : 100,000 Cycles
6. With Led : Option

STP-1193



Model No.	Color (Led)
STP 1193R	Red
STP 1193G	Green
STP 1193Y	Yellow

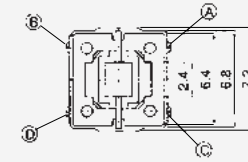

CIRCUIT DIAGRAM

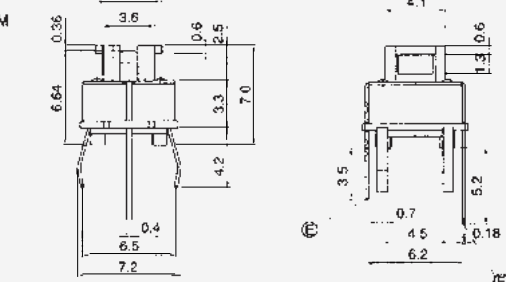
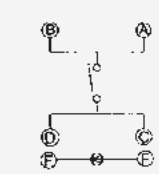

1. Rating : DC 12V, 50mA
2. Travel : 0.25±0.05 m/m
3. Operating Force : 160±30gf
4. Contact Resistance : 100mΩ Max.
5. Life : 100,000 Cycles
6. With Led : Option

TC-1193 CAP



Model No.	TC 1193W	TC 1193BL	TC 1193R	TC 1193Y	TC 1193B	TC 1193GR	TC 1193O	TC 1193IV
Color	White	Blue	Red	Yellow	Black	Green	Orange	Ivory

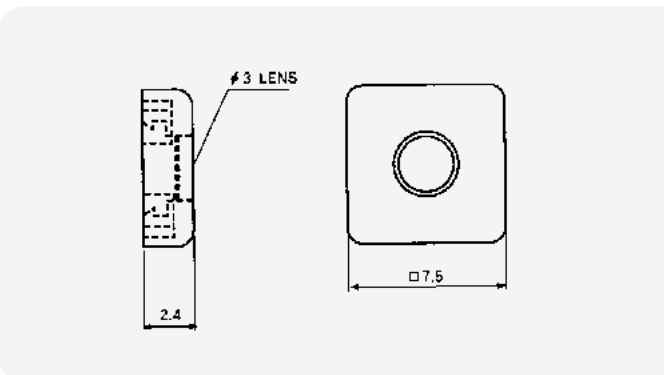

STP-1126



Model No.	Operating Force	Stem Color
STP1126	180±50gf	Red
STP1126S	260±50gf	Red

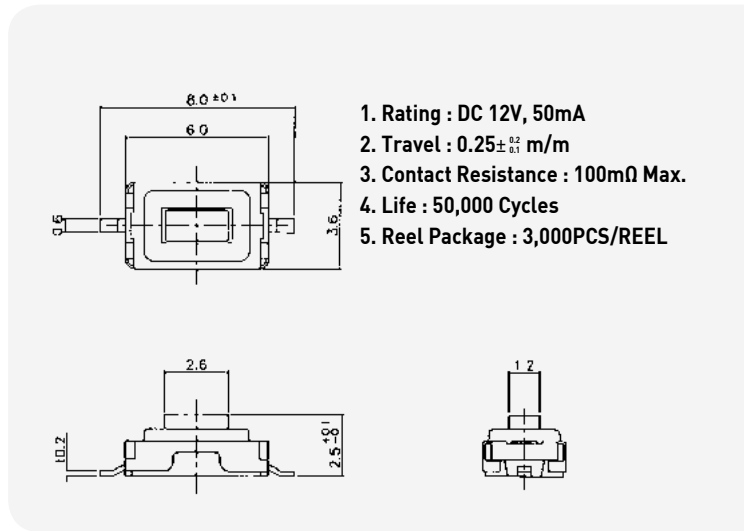

STP-1122A



Model No.	Operating Force	Stem Color
STP 1122A	160gf	Black
STS 1122AW	260gf	Red

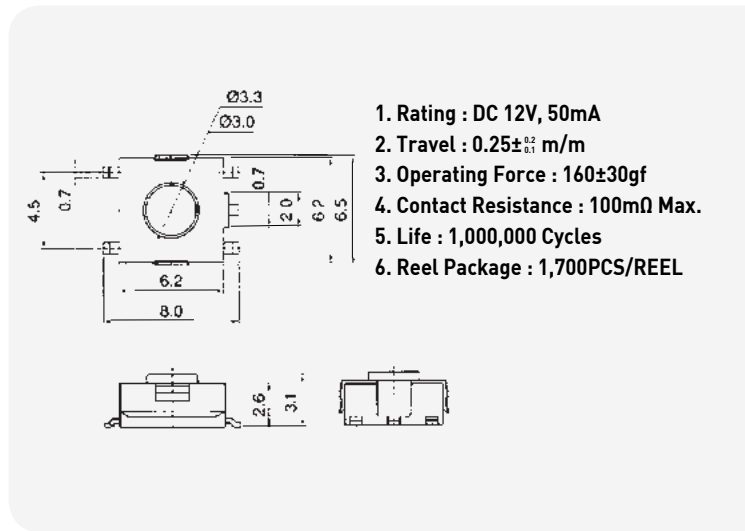

STP-1238



Model No.	STP 1238	STP 1238A	STP 1238H	STP 1238B	STP 1238C	STP 1238D	STP 1238E	STP 1238F	STP 1238G
L	4.3	5.0	6.0	9.5	8.0	13.0	7.3	8.5	7.0
Stem Color	Black	White	Black	Black	Black	Black	Ivory	Gray	Black
Reel Package	1K	1K	700	600	700	300	700	700	700

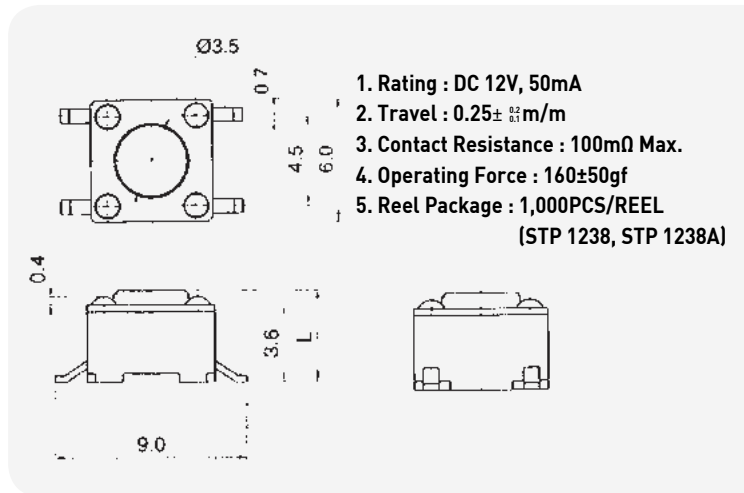

STP-1127C

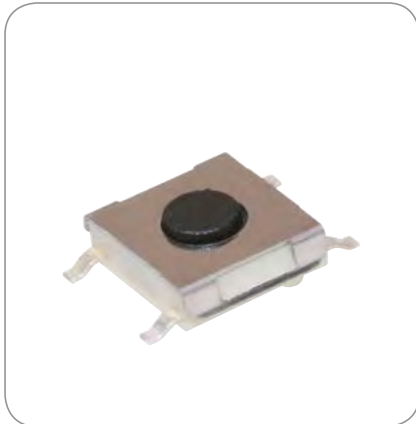

Model No.	Stem(L)
STP - 1127C	1.5
STP - 1127CA	4.3

1127, 1127A : Without Embossing

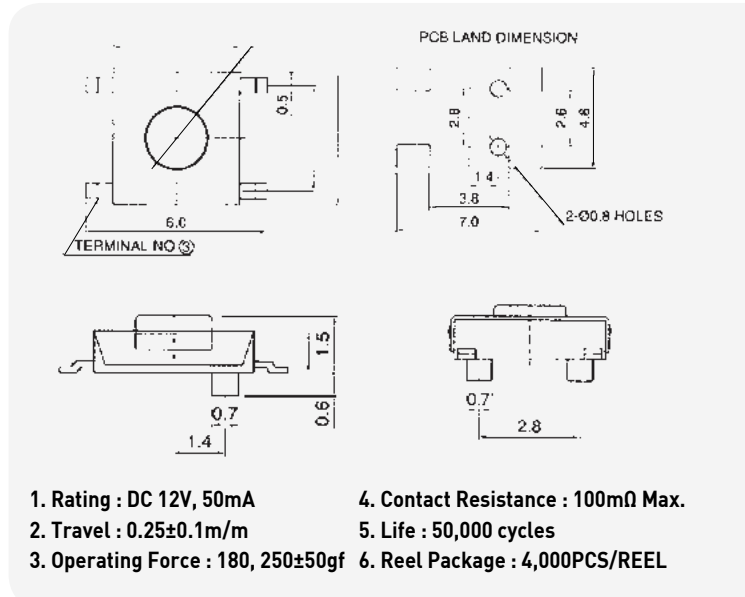

STP-1122



Model No.	Operating Force	Stem Color
STP 1122	160gf	Black
STS 1122W	260gf	Red

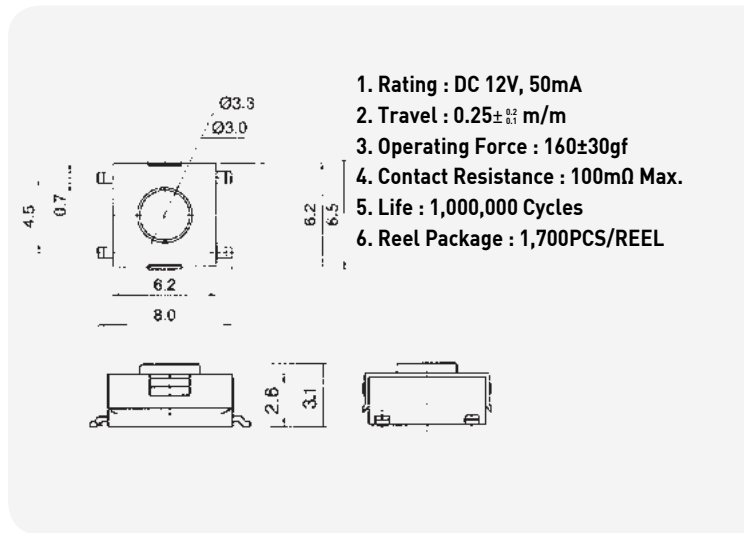

STP-1125

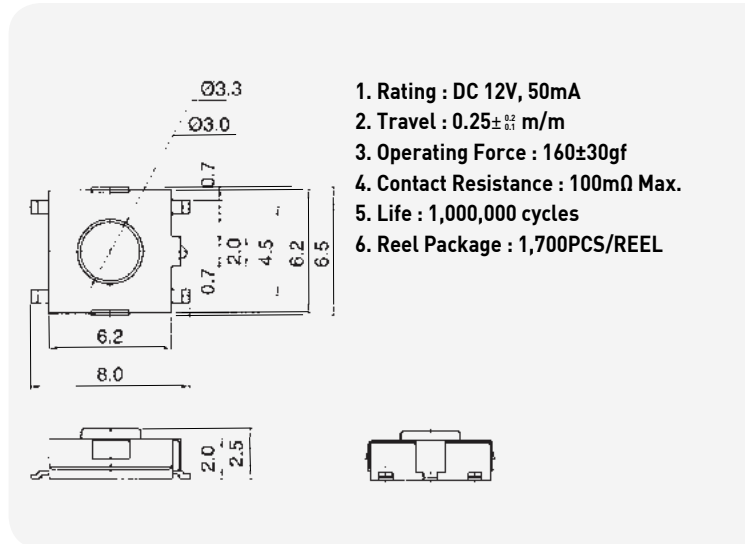

STP-1125B



- 1. Rating : DC 12V, 50mA
- 2. Travel :  $0.25 \pm 0.05$  m/m
- 3. Operating Force :  $160 \pm 30$ gf
- 4. Contact Resistance : 100m $\Omega$  Max.
- 5. Life : 1,000,000 cycles
- 6. Reel Package : 1,700PCS/REEL

STP-1100



- 1. Rating : DC 30V, 50mA
- 2. Travel : 0.2mm
- 3. Operating Force :  $200 \pm 30$ gf
- 4. Contact Resistance : 100m $\Omega$  Max.
- 5. Life : 100,000 Cycles
- 6. Reel Package : 3,500PCS/REEL

STP-1152

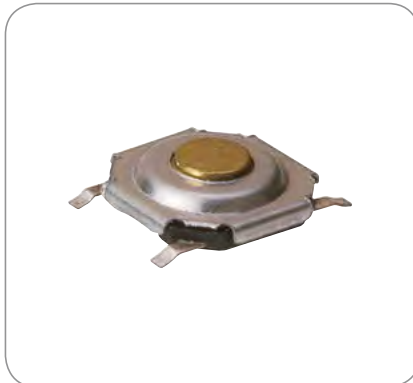

Model No.	Stem (L)
STP - 1152	1.5
STP - 1152A	4.3

Stem : Metal, Plastic

- 1. Rating : DC 12V, 50mA
- 2. Travel :  $0.25 \pm 0.1$ m/m
- 3. Operating Force :  $160 \pm 30$ gf  
 $250 \pm 50$ gf
- 4. Contact Resistance : 100m $\Omega$  Max.
- 5. Life : 100,000 cycles
- 6. Reel Package : 4,000PCS/REEL

STP-1112  
STP-1112 E



Model No.	Operating Force	Stem Color
STP 1112, STP 1112E	180gf	Black
STP 1112S, STP 1112ES	260gf	Red

- 1. Rating : DC 12V, 50mA
- 2. Travel : 0.25mm
- 3. Contact Resistance : 100m $\Omega$  Max.
- 4. Life : 50,000 Cycles
- 5. Reel Package : 2,000PCS/REEL

STP-1197



- 1. Rating : DC 12V 50mA
- 2. Travel :  $0.2 \pm 0.1$ m/m
- 3. Operating Force :  $160 \pm 30$ gf
- 4. Contact Resistance : 100m $\Omega$  Max.
- 5. Life : 50,000 Cycles
- 6. Reel Package : 7,000PCS/REEL

STP-1185  
STP-1185E



- 1. Rating : DC 12V, 50mA
- 2. Travel : 0.2mm
- 3. Contact Resistance : 100m $\Omega$  Max.
- 4. Life : 100,000 Cycles
- 5. Operating Force :  $220 \pm 30$ gf
- 6. Stem Color : Black
- 7. Reel Package : 3,000PCS/REEL



STP-1185U  
STP-1185UE

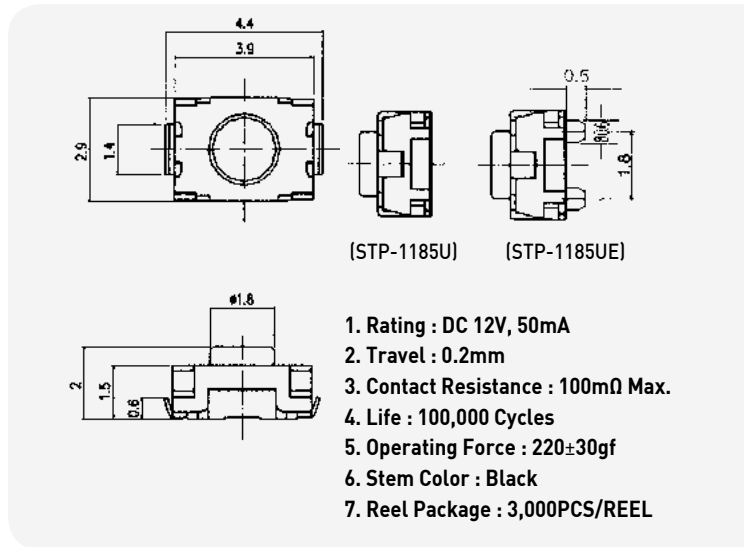

STP-1199

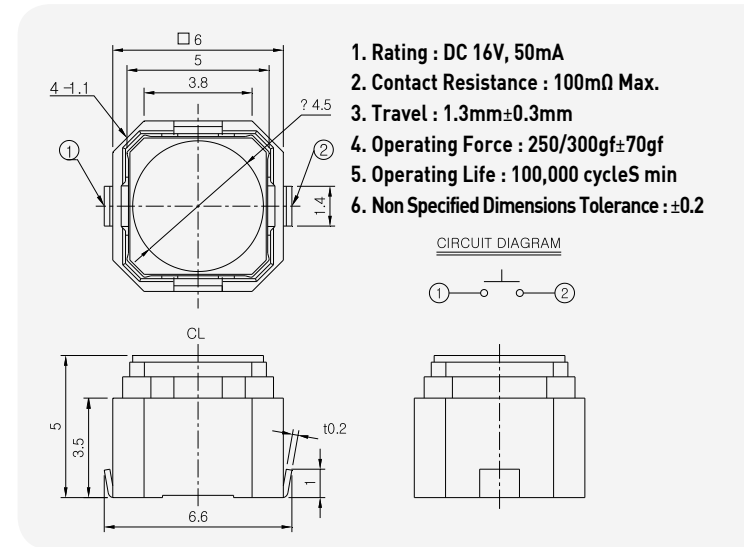

STP-1159

WATER PROOF SWITCH



Model No.	L	Stem Color
STP 1159	4.0	Blue
STP 1159A	5.0	Gray
STP 1159B	7.0	Black
STP 1159C	10.0	Black

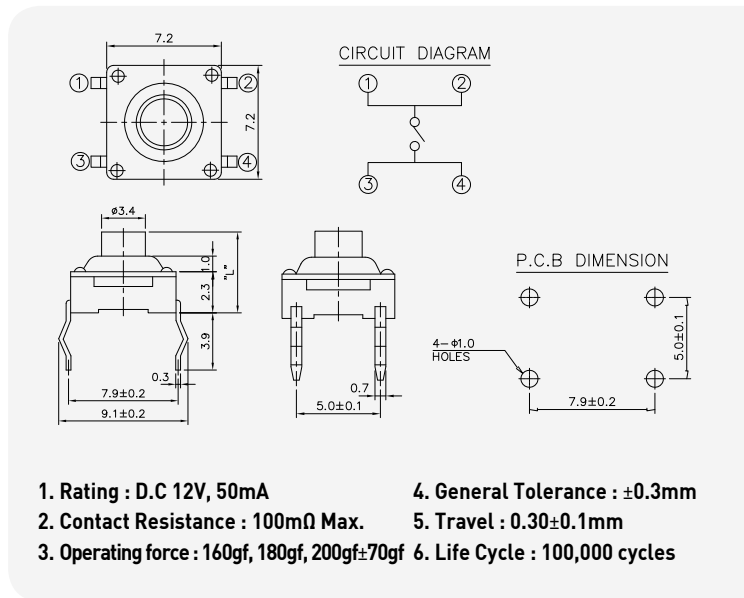

STP-1212



Model No.	L
STP 1212	4.3
STP 1212A	7.5

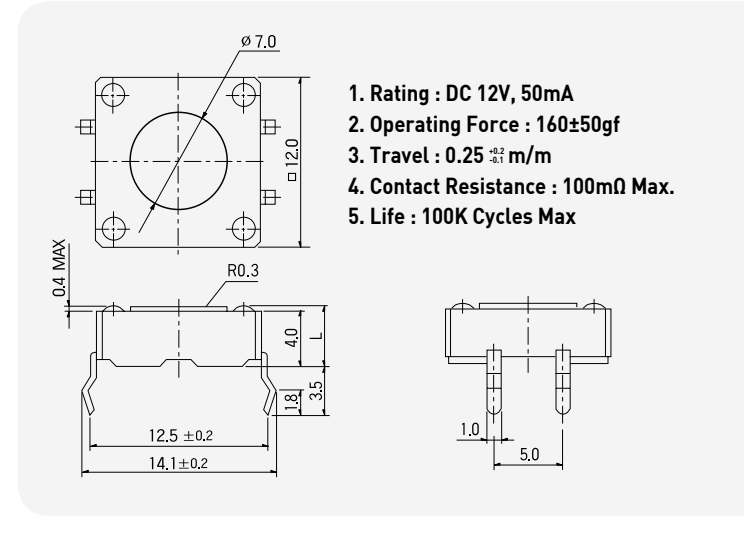

STP-1159S

WATER PROOF SWITCH



Model No.	L	Stem Color	Package
STP 1159S	4.3	Blue	1,000pcs/reel
STP 1159SA	5.0	Gray	1,000pcs/reel
STP 1159SB	7.0	Black	800pcs/reel

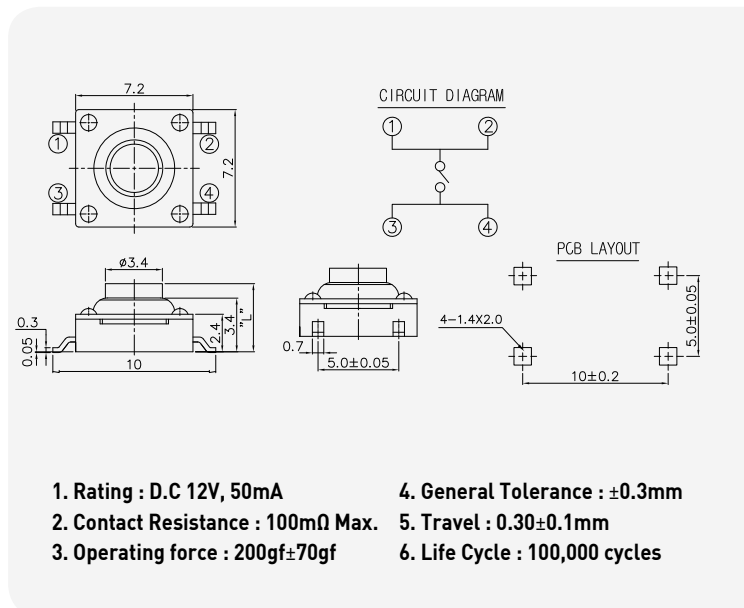

STP-1280



Model No.	L	Stem Color
STP 1280	4.3	Black
STP 1280A	5.0	Black

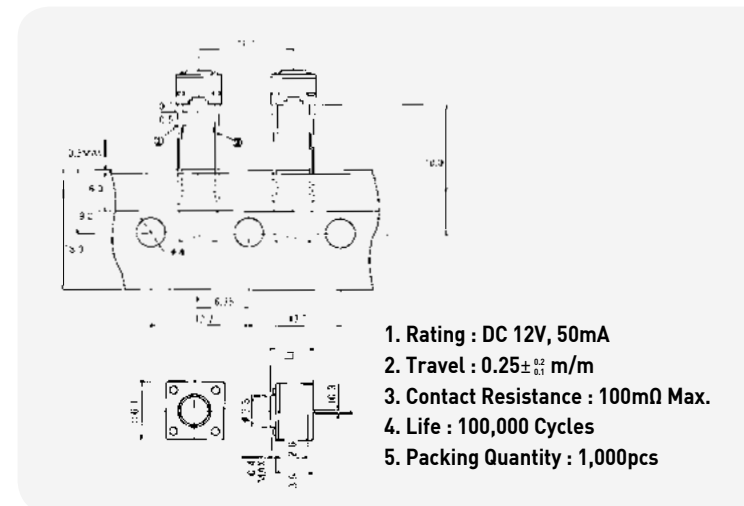

STP-1286

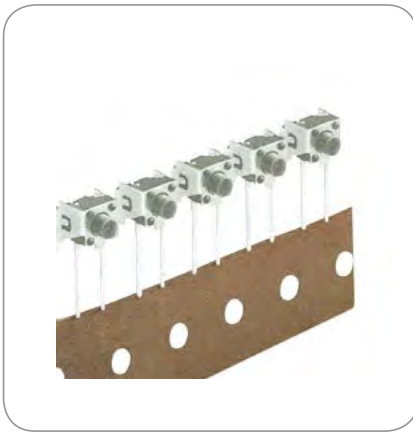

Model No.	Operating Force	Stem Color
STP 1286	160±50gf	Black

1. Rating : DC 12V, 50mA
2. Travel : 0.25±0.1m/m
3. Contact Resistance : 100mΩ Max.
4. Life : 100,000 Cycles
5. Packing Quantity : 650pcs

STP-1129



Model No.	Operating Force	Stem Color
STP 1129	160gf	White
STP 1129A	260gf	Gray

1. Rating : DC 12V, 50mA
2. Contact Resistance : 100mΩ Max.
3. Operating Force : 160gf±70gf  
260gf±70gf
4. General Tolerance : ±0.3mm
5. Travel : 0.35±0.1m/m
6. Life Cycle : 100,000 cycle
7. Packing : 700pcs/box

STP-1179

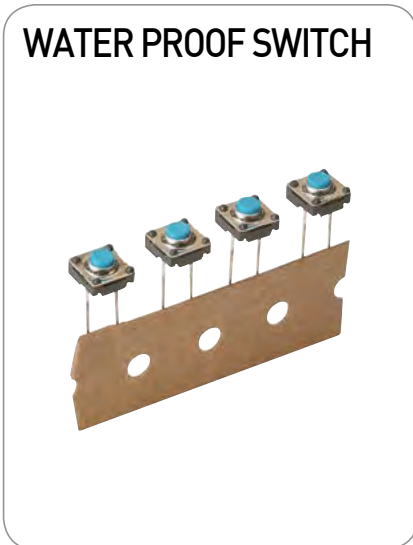

1. Rating : DC 12V 50mA
2. Contact Resistance : 100mΩ Max.
3. Operating Force : 260gf±70gf
4. General Tolerance : ±0.3mm
5. Travel : 0.25±0.1mm
6. Life Cycle : 100,000 cycle
7. Packing : 800pcs/box

**HOOK SWITCHES**

SH-1240A



**P.C.B Mounting Hole Dimensions**

**Circuit Diagram**

**Time Lag Diagram**

STP-1169

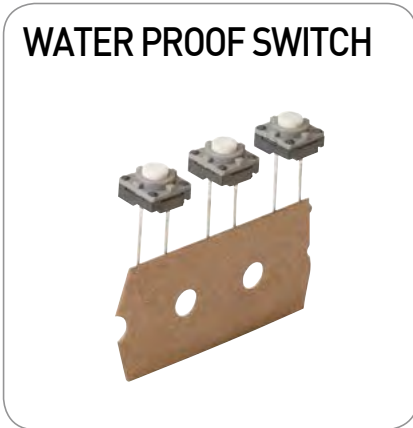

Model No.	Stem(L)	Stem Color
STP 1169	5.0	Gray
STP 1169A	7.0	Black
STP 1169B	10.0	Black

1. Rating : DC 12V, 50mA
2. Contact Resistance : 100mΩ Max.
3. Operating Force : 260gf±70gf
4. General Tolerance : ±0.3mm
5. Travel : 0.25±0.1mm
6. Life Cycle : 100,000 cycle
7. Packing : 800pcs/box

1. Rating : DC 48V, 0.2A
2. Circuit : 1C-1P
3. Contact Resistance : 50mΩ Max.
4. Operating Force : 12~20gf

SPS-2271

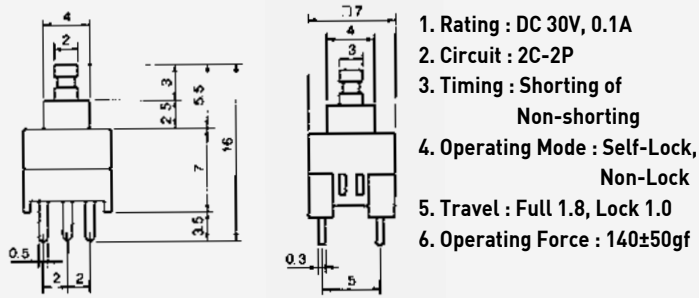

SPS-2284

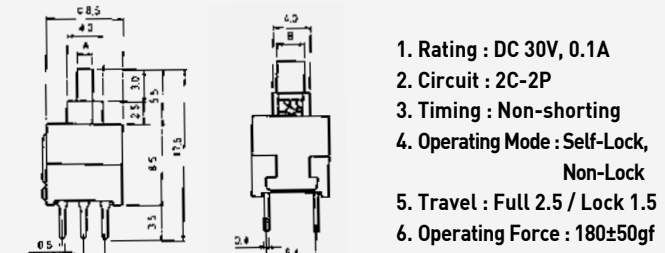

Model No.	SPS 2284	SPS 2284A	SPS 2284B
A	2.0	3.0	3.3
B	3.0	3.0	3.3

SPS-2259

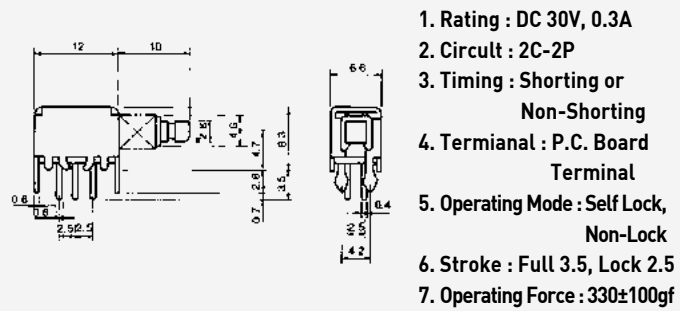

TC 1104  
TC 1108 CAP

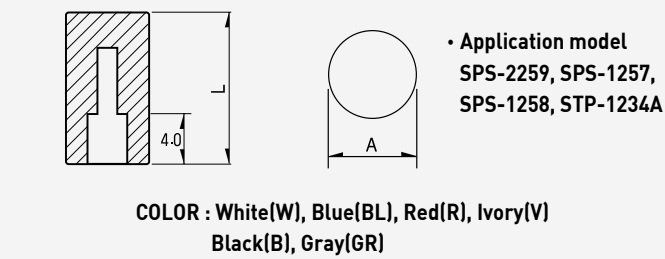

Model No.	A	L
TC 1104	∅ 5.0	9.0
TC 1108	∅ 7.0	12.0